



M.S.KENNEDY CORP.

**RAD HARD ULTRA LOW
DROPOUT ADJUSTABLE
POSITIVE LINEAR REGULATOR**

5821RH

4707 Dey Road Liverpool, N.Y. 13088

(315) 701-6751

FEATURES:

- Manufactured using  Space Qualified RH1573 Die
- New "Harder" Version of MSK 5921RH
- Total Dose Tested to 450K RAD (Method 1019.7 Condition A)
- Ultra Low Dropout for Reduced Power Consumption
- External Shutdown
- Latching Overload Protection
- Adjustable Output Using Two External Resistors
- Output Current Limit
- Available in 3 Lead Form Options: Straight, Up and Down
- Available to DSCC SMD 5962F09216
- ELDRS Tested to 100 Krads(Si) (Method 1019.7 Condition D)

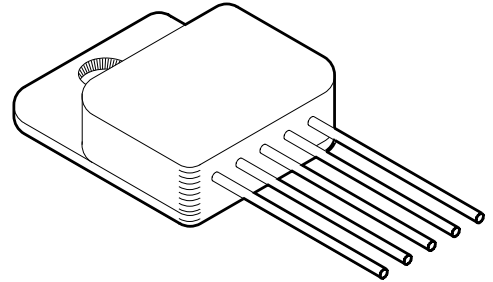

DESCRIPTION:

The MSK 5821RH is a radiation hardened adjustable linear regulator typically capable of delivering 5.0 amps of output current. The typical dropout is only 0.30 volts with a 3.0A load. An external shutdown function is ideal for power supply sequencing. This device also has latching overload protection that requires no external current sense resistor. The MSK 5821RH is radiation hardened and specifically designed for space/satellite applications. The device is packaged in a hermetically sealed space efficient 5 pin SIP that is electrically isolated from the internal circuitry allowing for direct heat sinking.

EQUIVALENT SCHEMATIC

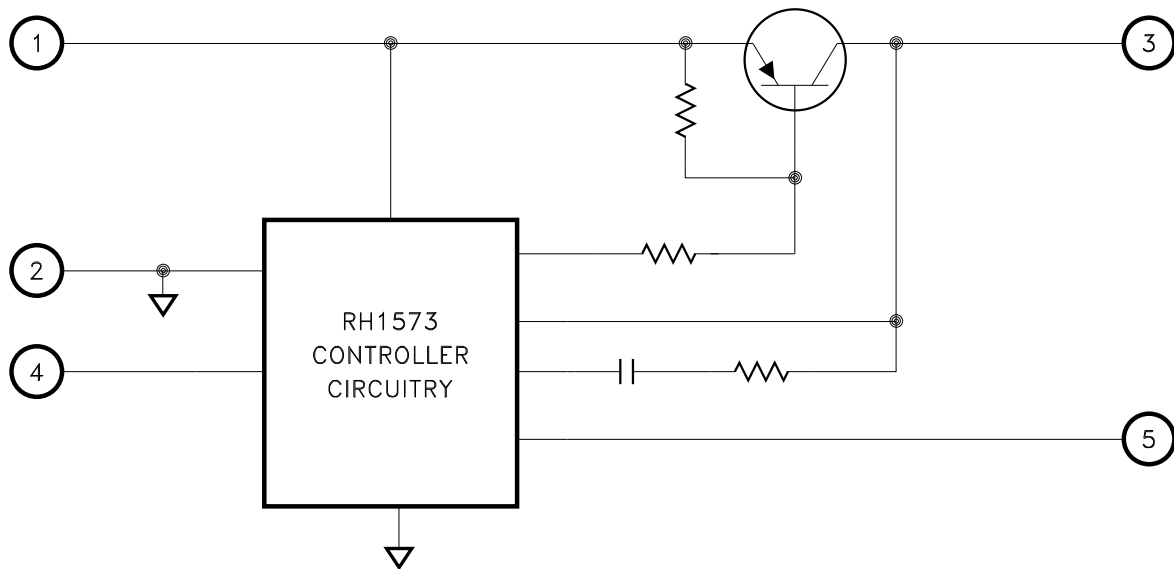

TYPICAL APPLICATIONS

- Satellite System Power Supplies
- Switching Power Supply Post Regulators
- Constant Voltage/Current Regulators
- Microprocessor Power Supplies

PIN-OUT INFORMATION

- 1 VIN
- 2 GND
- 3 VOUT
- 4 SHUTDOWN
- 5 ADJUST

ABSOLUTE MAXIMUM RATINGS ^⑧

$+V_{IN}$	Supply Voltage	+10V	T_{ST}	Storage Temperature Range	-65°C to +150°C
I_{OUT}	Output Current ^⑦	5A	T_{LD}	Lead Temperature Range	300°C
T_C	Case Operating Temperature Range			(10 Seconds)	
	MSK5821K/H/E RH	-55°C to +125°C	P_D	Power Dissipation	See SOA Curve
	MSK5821RH	-40°C to +85°C	T_C	Junction Temperature	150°C

ELECTRICAL SPECIFICATIONS

Parameter	Test Conditions ^{①⑩}	Group A Subgroup	MSK5821K/H/E			MSK5821			Units		
			Min.	Typ.	Max.	Min.	Typ.	Max.			
Input Voltage Range ^②	$10mA \leq I_{OUT} \leq 1.0A$	1	2.9	-	6.5	2.9	-	6.5	V		
		2,3	2.9	-	6.5	-	-	-	V		
Feedback Voltage	$I_{OUT} = 1A$ $R_1 = 187\Omega$	1	1.225	1.265	1.305	1.202	1.265	1.328	V		
		2,3	1.225	-	1.305	-	-	-	V		
			Post 100KRAD(Si)	1	1.225	-	1.305	1.202	-	1.328	V
			Post 300KRAD(Si)	1	1.225	-	1.310	1.202	-	1.328	V
Feedback Pin Current ^②	$V_{FB} = 1.265V$ $10mA \leq I_{OUT} \leq 3.0A$	1,2,3	0	-	5.0	0	-	5.0	μA		
Quiescent Current	$V_{IN} = 6.5V$ Not Including I_{OUT}	1	-	14	20	-	14	20	mA		
		2,3	-	14	20	-	-	-	mA		
Line Regulation ^⑨	$I_{OUT} = 50mA$ $V_{OUT} + 0.4V \leq V_{IN} \leq V_{OUT} + 1.3V$	1	-	± 0.01	± 0.50	-	0.01	± 0.60	% V_{OUT}		
		2,3	-	-	± 2.5	-	-	-	% V_{OUT}		
Load Regulation ^⑨	$50mA \leq I_{OUT} \leq 3.0A$	1	-	± 0.06	± 0.80	-	0.06	± 1.0	% V_{OUT}		
		2,3	-	-	± 2.5	-	-	-	% V_{OUT}		
Dropout Voltage ^⑩	Delta FB = 1% $I_{OUT} = 2.5A$	1	-	0.22	0.40	-	0.22	0.45	V		
		2,3	-	0.26	0.40	-	-	-	V		
Minimum Output Current ^②	$2.9V \leq V_{IN} \leq 6.5V$ $R_1 = 187\Omega$	1	-	8	10	-	8	10	mA		
		2,3	-	9	10	-	-	-	mA		
Output Voltage Range ^②	$V_{IN} = 6.5V$	-	1.5	-	6.0	1.5	-	6.0	V		
Output Current Limit ^⑦	$V_{IN} = 3.5V$ $V_{OUT} = 2.5V$	1	3.0	4.0	5.0	3.0	4.0	5.0	A		
		2,3	3.0	4.0	5.0	-	-	-	A		
Shutdown Threshold	$V_{OUT} \leq 0.2V$ (OFF) $V_{OUT} = \text{Nominal}$ (ON)	1	1.0	1.3	1.6	1.0	1.3	1.6	V		
		2,3	1.0	1.3	1.6	-	-	-	V		
Ripple Rejection ^②	$f = 120Hz$ $I_{OUT} = 50mA$	4	65	-	-	65	-	-	dB		
		5,6	65	-	-	-	-	-	dB		
Phase Margin ^②		4	30	-	-	30	-	-	degrees		
Gain Margin ^②		4	10	18	-	10	18	-	dB		
Equivalent Noise Voltage ^②	Referred to Feedback Pin	4,5,6	-	-	50	-	-	50	μV_{RMS}		
Thermal Resistance ^②	Junction to Case @ 125°C Output Device	-	-	2.2	4.0	-	2.2	4.0	°C/W		

NOTES:

- ① Unless otherwise specified, $V_{IN} = 5.0V$, $R_1 = 1.62K$, $V_{SHUTDOWN} = 0V$ and $I_{OUT} = 10mA$. See Figure 2, typical application circuits.
- ② Guaranteed by design but not tested. Typical parameters are representative of actual device performance but are for reference only.
- ③ Industrial grade and "E" suffix devices shall be tested to subgroups 1 and 4 unless otherwise requested.
- ④ Military grade devices ("H" suffix) shall be 100% tested to subgroups 1,2,3 and 4.
- ⑤ Subgroup 5 and 6 testing available upon request.
- ⑥ Subgroup 1,4 $T_C = +25^\circ C$
Subgroup 2,5 $T_C = +125^\circ C$
Subgroup 3,6 $T_A = -55^\circ C$
- ⑦ Output current limit is dependent upon the values of V_{IN} and V_{OUT} . See Figure 1 and typical performance curves.
- ⑧ Continuous operation at or above absolute maximum ratings may adversely effect the device performance and/or life cycle.
- ⑨ V_{IN} shall be as specified or V_{IN} Min, whichever is greater.
- ⑩ Not applicable when $V_{OUT} < V_{IN}$ Min - dropout voltage maximum.
- ⑪ Pre and post irradiation limits, up to 300Krad TID, are identical unless otherwise specified.
- ⑫ Reference DSCC SMD 5962F09216 for electrical specification for devices purchased as such.

APPLICATION NOTES

PIN FUNCTIONS

VIN - This pin provides power to all internal circuitry including bias, start-up, thermal limit and overcurrent latch. Input voltage range is 2.9V to 6.5V.

GND - Internally connected to ground, this pin should be connected externally by the user to the circuit ground.

SHUTDOWN - There are two functions to the SHUTDOWN pin. It may be used to disable the output voltage or to reset a current latch condition. To activate the shutdown/reset functions the user must apply a voltage greater than 1.6V to the SHUTDOWN pin. The output voltage will turn on when the SHUTDOWN pin is pulled below the threshold voltage. If the SHUTDOWN pin is not used, it should be connected to ground. It should be noted that with the shutdown pin tied to ground, a current latch condition can only be reset by cycling power off, then on.

VOUT - This is the output pin for the device.

ADJUST - The ADJUST pin is the inverting input of the internal error amplifier. The non-inverting input is connected to an internal 1.265V reference. This error amplifier controls the drive to the output transistor to force the ADJUST pin to 1.265V. An external resistor divider is connected to the output, ADJUST pin and ground to set the output voltage.

OVERCURRENT LATCH

Overcurrent protection is provided by the MSK5821RH series through the use of a timed latch off circuit. The internal latch timeout is triggered by an overcurrent condition. To allow for start up surge currents, the timeout is approximately 5.5mS at 25°C. If the overcurrent condition remains at the end of the timeout cycle, the regulator will latch off until the latch is reset. Reset the latch by pulling the shutdown pin high or cycling VIN off then back on. A thermal limit condition will trigger the latch with no time out delay.

INPUT POWER SUPPLY BYPASSING

To maximize transient response and minimize power supply transients it is recommended that a 100 μ F tantalum capacitor is connected between VIN and ground. A 0.1 μ F ceramic capacitor should also be used for high frequency bypassing.

OUTPUT CAPACITOR SELECTION

Output capacitors are required to maintain regulation and stability. Between 440 and 1000 μ F surface mount, low ESR, tantalum capacitor from the output to ground should suffice under most conditions. See typical application circuit for recommended values. Ceramic output capacitors (0.1 μ F typical) should be placed directly across the load power connections as close to the load as possible. If the user finds that tighter voltage regulation is needed during output transients, more capacitance may be added. If more capacitance is added to the output, the bandwidth may suffer.

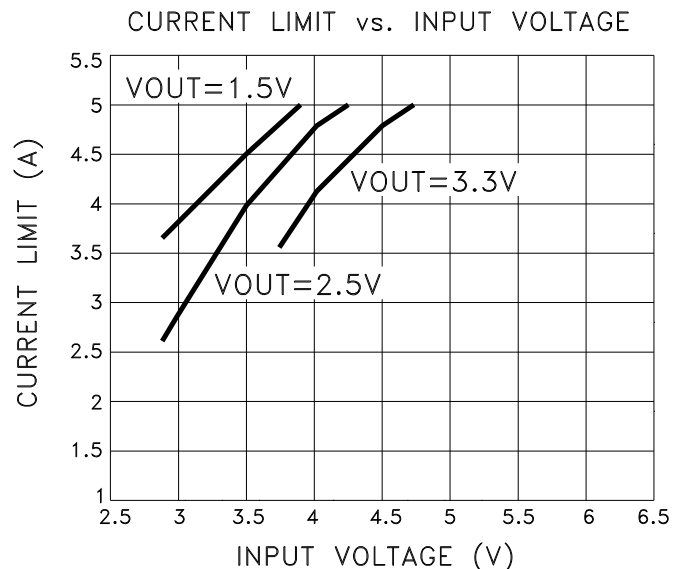

FIGURE 1

CURRENT LIMIT AND SOA

The MSK 5821RH current limit function is directly affected by the input and output voltages. Figure 1 illustrates the relationship between VIN and ICL for various output voltages. It is very important for the user to consult the SOA curve when using input voltages which result in current limit conditions beyond 4.5 Amps. When using input voltages which result in current limit above 4.5 Amps, the user must maintain output current within the SOA curve to avoid damage to the device. Note that 5 Amp maximum is due to current carrying capability of the internal wirebonds.

APPLICATION NOTES CONT.

THERMAL LIMITING

The MSK 5821RH control circuitry has a thermal shut-down temperature of approximately 150°C. This thermal shutdown can be used as a protection feature, but for continuous operation, the junction temperature of the pass transistor must be maintained below 150°C. Proper heat sink selection is essential to maintain these conditions. Exceeding the thermal limit activates the latch feature of the MSK 5821RH. Toggle the shutdown pin high then low or cycle power to reset the latch. See SHUTDOWN pin description and overcurrent latch description for more information.

HEAT SINK SELECTION

To select a heat sink for the MSK 5821RH, the following formula for convective heat flow may be used.

Governing Equation:

$$T_J = P_D \times (R_{\theta JC} + R_{\theta CS} + R_{\theta SA}) + T_A$$

Where

- T_J = Junction Temperature
- P_D = Total Power Dissipation
- $R_{\theta JC}$ = Junction to Case Thermal Resistance
- $R_{\theta CS}$ = Case to Heat Sink Thermal Resistance
- $R_{\theta SA}$ = Heat Sink to Ambient Thermal Resistance
- T_A = Ambient Temperature

$$\text{Power Dissipation} = (V_{IN} - V_{OUT}) \times I_{OUT}$$

Next, the user must select a maximum junction temperature. The absolute maximum allowable junction temperature is 150°C. The equation may now be rearranged to solve for the required heat sink to ambient thermal resistance ($R_{\theta SA}$).

Example:

An MSK 5821RH is connected for $V_{IN} = +3.3V$ and $V_{OUT} = +2.5V$. I_{OUT} is a continuous 3A DC level. The ambient temperature is +25°C. The maximum desired junction temperature is +125°C.

$R_{\theta JC} = 4.0^\circ C/W$ and $R_{\theta CS} = 0.15^\circ C/W$ for most thermal greases

$$\text{Power Dissipation} = (3.3V - 2.5V) \times (3A) = 2.4 \text{ Watts}$$

Solve for $R_{\theta SA}$:

$$R_{\theta SA} = \left[\frac{125^\circ C - 25^\circ C}{2.4W} \right] - 4.0^\circ C/W - 0.15^\circ C/W = 36.5^\circ C/W$$

In this example, a heat sink with a thermal resistance of no more than 36.5°C/W must be used to maintain a junction temperature of no more than 125°C.

TYPICAL APPLICATIONS CIRCUIT

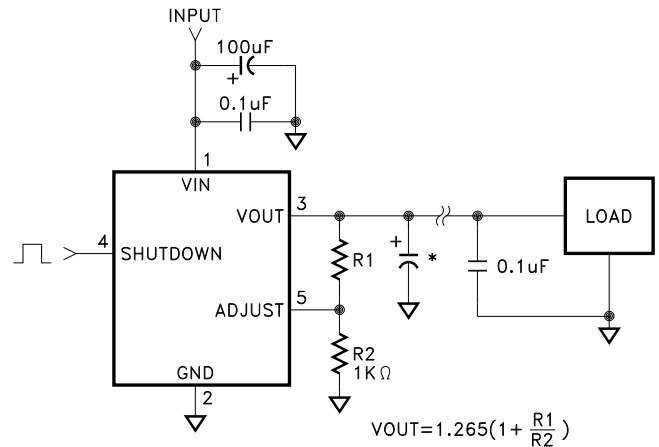

* 4 PIECES AVX PART NUMBER
TAZH227K010L (CWR29FB227)

OUTPUT VOLTAGE SELECTION

As noted in the above typical applications circuit, the formula for output voltage selection is

$$V_{OUT} = 1.265 \left[1 + \frac{R_1}{R_2} \right]$$

A good starting point for this output voltage selection is to set $R_2 = 1K$. By rearranging the formula it is simple to calculate the final R_1 value.

$$R_1 = R_2 \left[\frac{V_{OUT}}{1.265} - 1 \right]$$

Table 1 below lists some of the most probable resistor combinations based on industry standard usage.

START UP CURRENT

The MSK 5821RH sinks increased current during startup to bring up the output voltage. Reference the "Saturated Drive Current vs. Input Voltage" graph in the typical performance curves of this data sheet and the "Understanding Startup Surge Current With MS Kennedy's RH1573 Based Rad Hard LDO Regulators" application note in the application notes section of the MS Kennedy Web site for more information.

<http://www.mskennedy.com/>

TOTAL DOSE RADIATION TEST PERFORMANCE

Radiation performance curves for TID testing have been generated for all radiation testing performed by MS Kennedy. These curves show performance trends throughout the TID test process and can be located in the MSK 5810RH radiation test report. The complete radiation test report is available in the RAD HARD PRODUCTS section on the MSK website.

<http://www.mskennedy.com/store.asp?pid=9951&catid=19680>

Reference the MSK 5826RH RAD REPORT for ELDRS Results.

TYPICAL PERFORMANCE CURVES

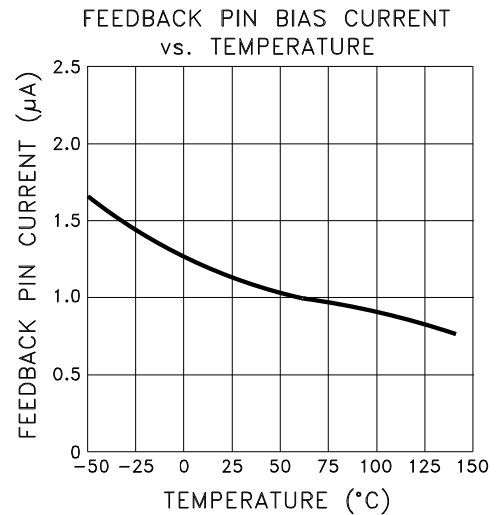
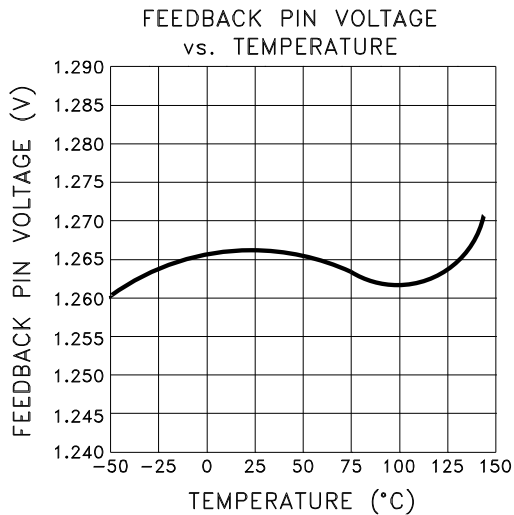
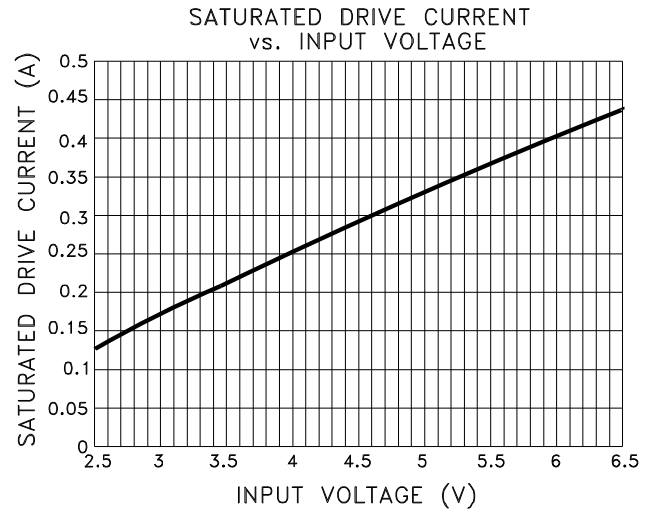
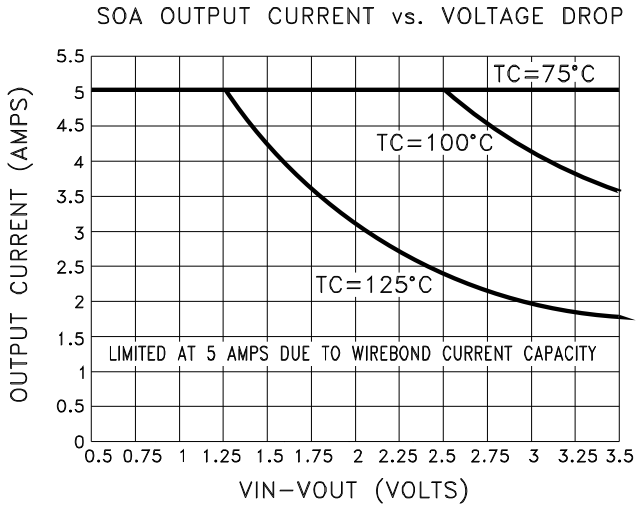
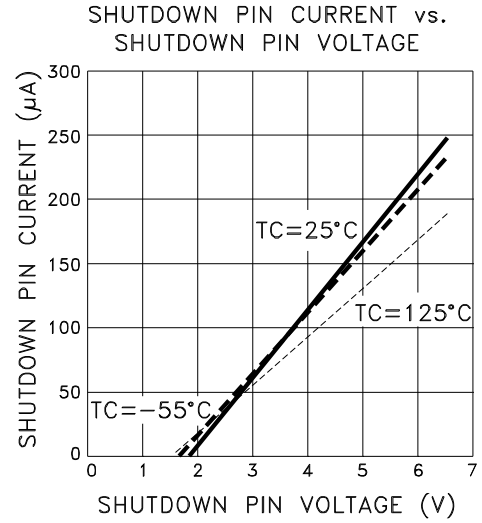
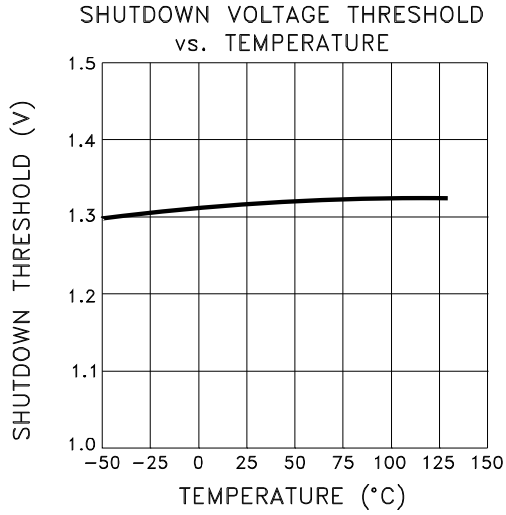

TYPICAL PERFORMANCE CURVES

GAIN AND PHASE RESPONSE

The gain and phase response curves are for the MSK typical application circuit at 25°C and are representative of typical device performance, but are for reference only. The performance should be analyzed for each application to insure individual program requirements are met. External factors such as temperature, input and output voltages, capacitors, etc. all can be major contributors. Please consult factory for additional details.

MSK5821RH GAIN AND PHASE vs. FREQUENCY

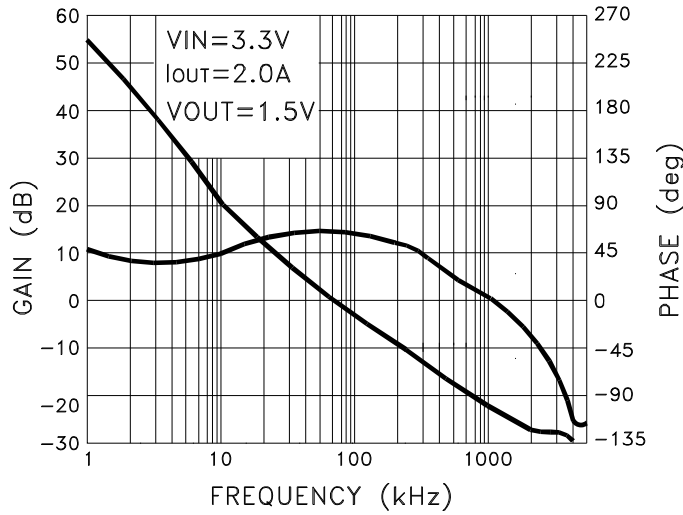

MSK5821RH GAIN AND PHASE vs. FREQUENCY

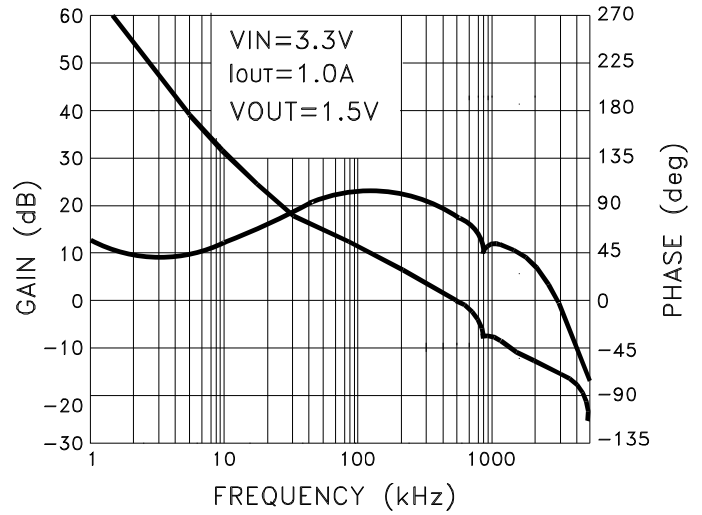

MSK5821RH GAIN AND PHASE vs. FREQUENCY

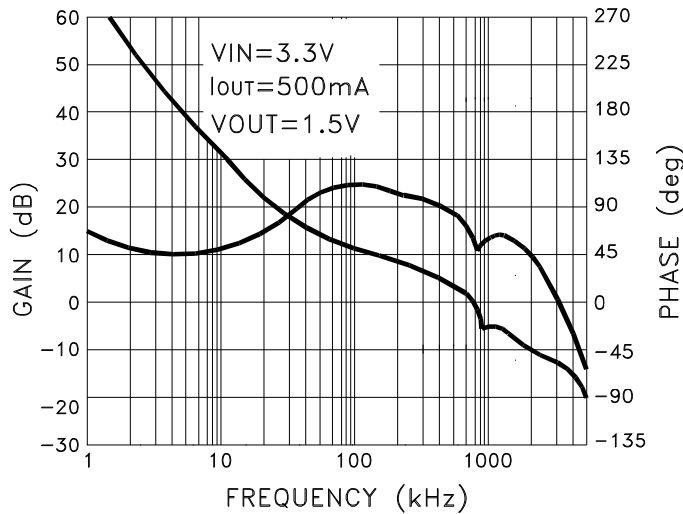

MSK5821RH GAIN AND PHASE vs. FREQUENCY

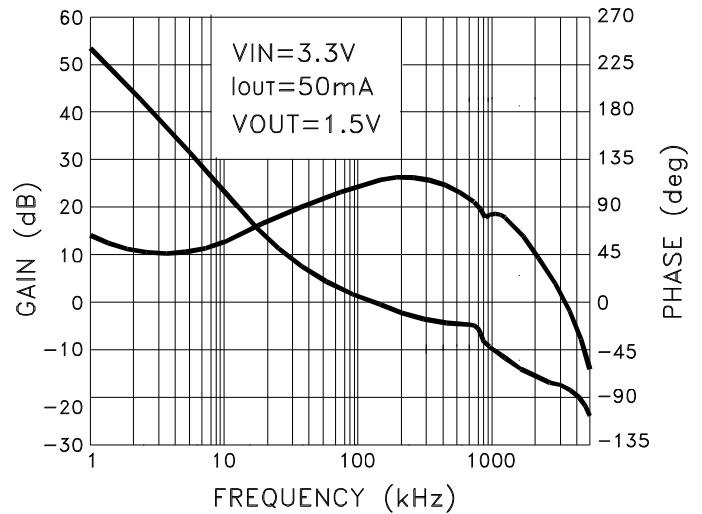

MECHANICAL SPECIFICATIONS

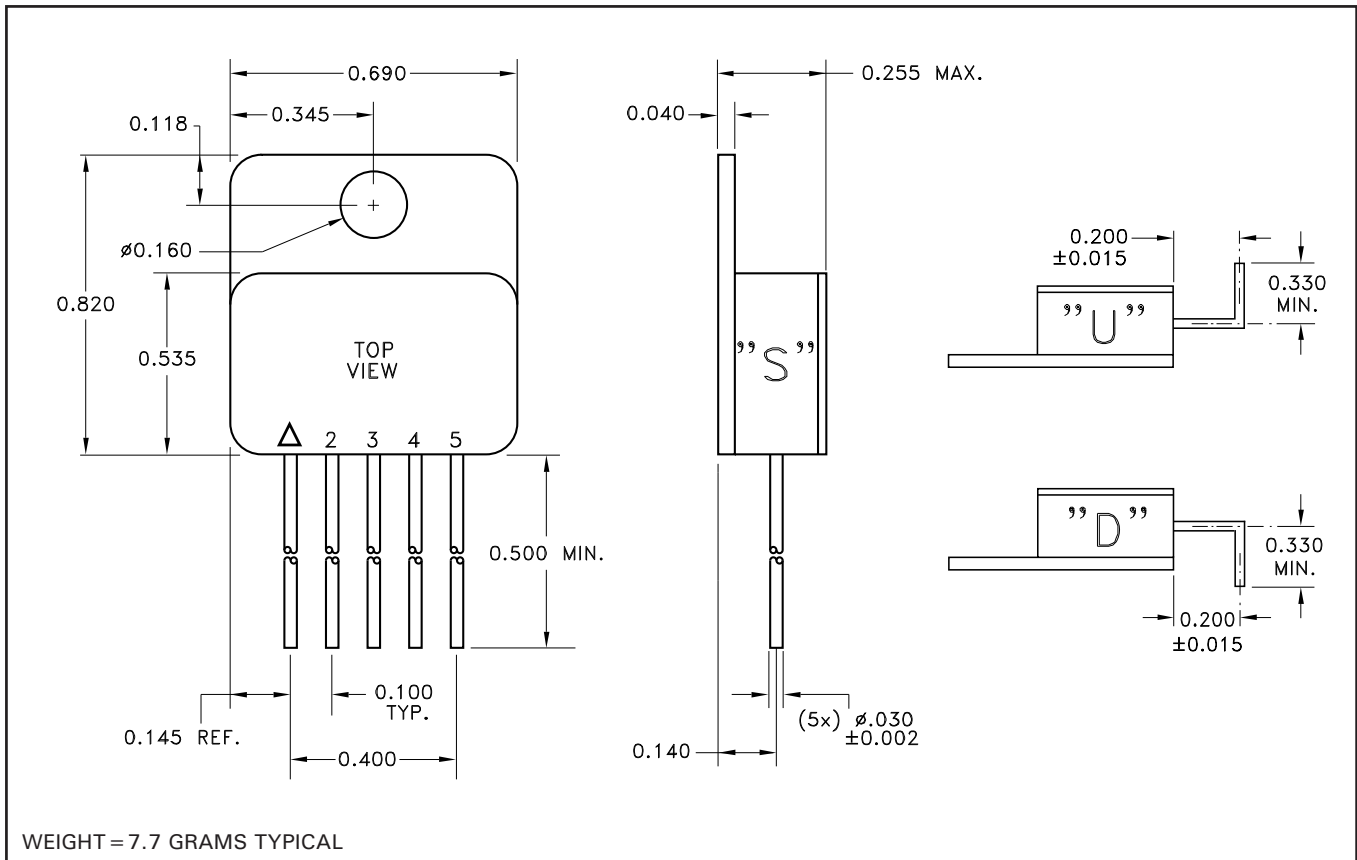

ALL DIMENSIONS ARE ± 0.010 INCHES UNLESS OTHERWISE LABELED.
ESD Triangle indicates pin 1.

ORDERING INFORMATION

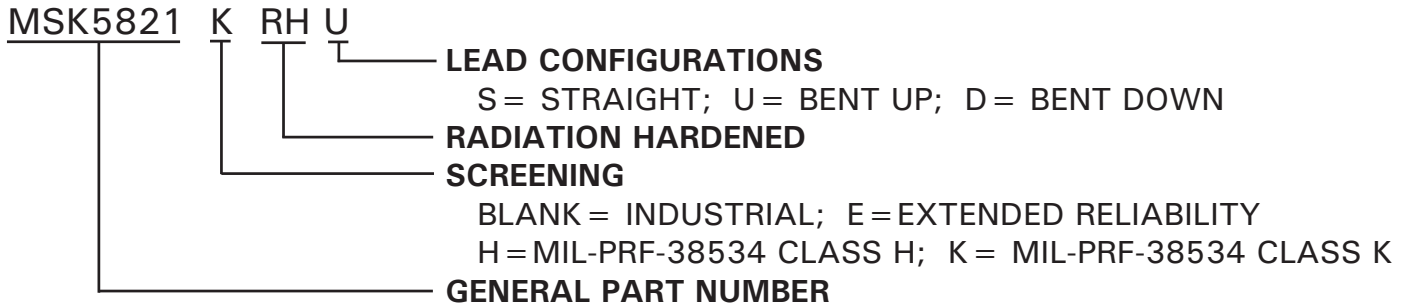

The above example is an adjustable Class K regulator with leads bent up.

NOTE: See DSCC SMD 5962F09216 for DSCC part number options.

M.S. Kennedy Corp.
4707 Dey Road, Liverpool, New York 13088
Phone (315) 701-6751
FAX (315) 701-6752
www.mskennedy.com

The information contained herein is believed to be accurate at the time of printing. MSK reserves the right to make changes to its products or specifications without notice, however, and assumes no liability for the use of its products. Please visit our website for the most recent revision of this datasheet.