



**RAD HARD 3.5A
SWITCHING REGULATOR**

5044RH

M.S.KENNEDY CORP.

4707 Dey Road Liverpool, N.Y. 13088

(315) 701-6751

FEATURES:



- Manufactured using Rad Hard RH1959MILDICE
- Total Dose Tested to TBD Krad(Si) (Method 1019.7 Condition A)
- Improved Replacement for Satcon SAT8565A
- Adjustable Output Voltage from 1.21 to 5V
- Input Voltage Range from 4.3V to 16V
- Constant 500KHz Switching Frequency
- Shutdown Pin
- Short Circuit and Thermal Limit Protection
- Available in 3 Lead Form Options: Straight, Up and Down
- Contact MSK for MIL-PRF-38534 Qualification Status

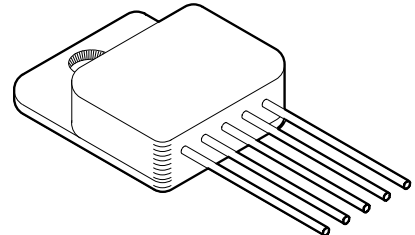

DESCRIPTION:

The MSK 5044RH is a radiation hardened adjustable output voltage switching regulator. A wide input and output voltage range with 3.5A output current capability make these regulators suitable for many applications. Excellent efficiency and a reduced output capacitance requirement are the results of a constant 500KHz switching frequency. The regulator output can be turned on and off remotely with low current logic levels via the shutdown pin for meeting power sequencing requirements. Short circuit current limit and thermal shutdown features provide fault protection. The MSK 5044RH is hermetically sealed in a space saving 5 pin power package and specifically designed for space/satellite applications.

EQUIVALENT SCHEMATIC

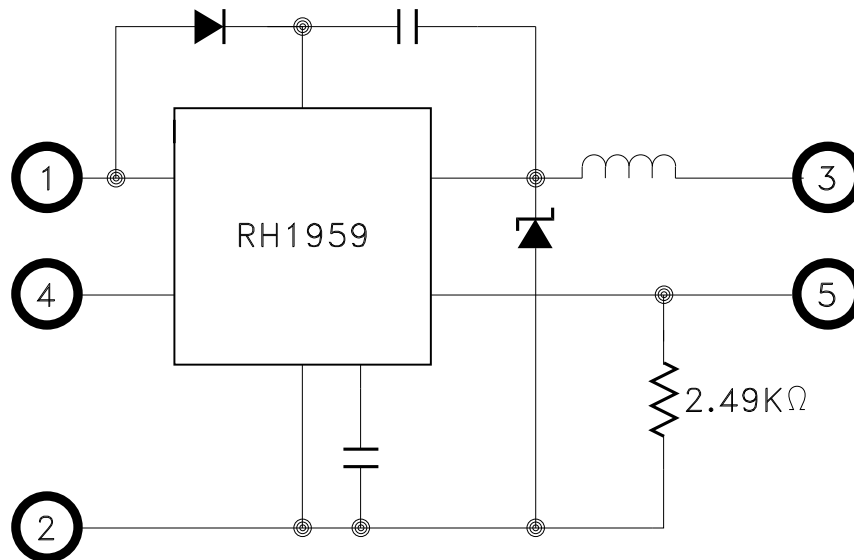

TYPICAL APPLICATIONS

- POL Applications
- Satellite System Power Supply
- Microprocessor, FPGA Power Source
- High Efficiency Low Voltage Subsystem Power Supply

PIN-OUT INFORMATION

- 1 VIN
- 2 GND
- 3 VOUT
- 4 SHDN
- 5 FB

LT and the Linear Technology logo are registered trademarks and RH1959MILDICE is a copyright of Linear Technology Corporation

ABSOLUTE MAXIMUM RATINGS ^⑦

V_{IN} Input Voltage 16V
 I_{OUT} Output Current 4A
 SHDN Pin Voltage 7.0V

T_{ST} Storage Temperature Range -65°C to +150°C
 T_{LD} Lead Temperature Range
 (10 Seconds) 300°C
 T_J Junction Temperature 150°C
 T_C Case Operating Temperature Range
 MSK 5044K/H/E RH. -55°C to +125°C
 MSK 5044RH. -40°C to +85°C

ELECTRICAL SPECIFICATIONS

| Parameter | Test Conditions ^① | Group A Subgroup | MSK 5044K/H/E RH | | | MSK 5044RH | | | Units |
|--|---|---------------------|------------------|------|------|------------|------|------|-------|
| | | | Min. | Typ. | Max. | Min. | Typ. | Max. | |
| Feedback Voltage(V _{FB}) | Post Radiation | 1,2,3 | 1.19 | 1.21 | 1.23 | 1.19 | 1.21 | 1.23 | V |
| | | 1 | TBD | TBD | TBD | TBD | TBD | TBD | V |
| Line Regulation | 4.3V ≤ V _{IN} ≤ 15V | 1,2,3 | -0.5 | - | 0.5 | -0.5 | - | 0.5 | % |
| | Post Radiation | 1 | TBD | - | TBD | TBD | - | TBD | % |
| Load Regulation | 1A ≤ I _{OUT} ≤ 3A | 1,2,3 | -1.0 | - | 1.0 | -1.0 | - | 1.0 | % |
| | Post Radiation | 1 | TBD | - | TBD | -1.0 | - | 1.0 | % |
| V _{IN} Input Supply Range ^② ^③ | | 1,2,3 | 4.3 | - | 15.0 | 4.3 | - | 15.0 | V |
| Output Voltage Range ^② | V _{IN} = 10.0V ΔV _{FB} = 1% | 1,2,3 | - | 9.1 | - | - | 9.1 | - | V |
| Efficiency | | 1 | 75 | 81.5 | - | 75 | 81.5 | - | % |
| | Post Radiation | 1 | TBD | TBD | - | TBD | TBD | - | % |
| Output Voltage Ripple | | 4 | - | 22 | 45 | - | 22 | 45 | mVpp |
| | Post Radiation | 4 | - | TBD | TBD | - | TBD | TBD | mVpp |
| Switching Frequency | | 4 | 460 | 500 | 540 | 460 | 500 | 540 | KHz |
| Current Limit | | 1,2,3 | 3.5 | 4.4 | - | 3.5 | 4.4 | - | A |
| | Post Radiation | 1 | TBD | - | - | TBD | - | - | A |
| V _{IN} Supply Current @ Shutdown (low power state) | V _{SHDN} = 0V | 1,2,3 | - | 41 | 75 | - | 41 | 75 | μA |
| | Post Radiation | 1 | - | - | TBD | - | - | TBD | μA |
| Shutdown Threshold Voltage (low power state) | | 1,2,3 | 0.13 | 0.40 | 0.60 | 0.13 | 0.40 | 0.60 | V |
| | Post Radiation | 1 | TBD | - | TBD | TBD | - | TBD | V |
| Thermal Resistance ^② | Junction to Case @125°C Forward Switch | - | - | 13.4 | 14.0 | - | 13.4 | 14.0 | °C/W |
| Thermal Resistance ^② | Junction to Case @125°C Catch Diode | - | - | 18.7 | 20 | - | 18.7 | 20 | °C/W |

NOTES:

- ① Unless otherwise specified V_{IN} = 5.0V, V_{OUT} = 2.5V and I_{OUT} = 1.0A. See Figure 1 for typical application circuit.
- ② Guaranteed by design but not tested. Typical parameters are representative of actual device performance but are for reference only.
- ③ Industrial grade and "E" suffix devices shall be tested to subgroup 1 and 4 unless otherwise specified.
- ④ Military grade devices ("H" Suffix) shall be 100% tested to subgroups 1,2,3 and 4.
- ⑤ Subgroup 5 & 6 testing available on request.
- ⑥ Subgroup 1,4 TA = TC = +25°C
 2,5 TA = TC = +125°C
 3,6 TA = TC = -55°C
- ⑦ Continuous operation at or above absolute maximum ratings may adversely effect the device performance and/or life cycle.
- ⑧ Pre and Post irradiation limits at 25°C, up to TBD Krad(Si) TID, are identical unless otherwise specified.
- ⑨ Verified during line regulation test.

APPLICATION NOTES

PIN FUNCTIONS

VIN - VIN connects to the collector of the internal power switch and provides power to the internal control circuitry and internal regulator. Very high di/dt is seen at VIN during switch on and off transitions. High frequency decoupling capacitors are recommended to minimize voltage spikes. VIN should be connected to a low impedance source for best operation.

FB - The FB (feedback) pin's primary function is to set the output voltage to the desired level. Use a single resistor between VOUT and FB to form a feedback divider network with the internal 2.49K resistor. Select the external resistor value to set the voltage at the FB pin to 1.21V when the output is at the desired level, see "**Setting The Output Voltage.**" The FB pin provides two additional functions. If the voltage at the FB pin drops below 0.8V the switch current limit is reduced. When the voltage at the FB pin drops below 0.7V the switching frequency is reduced. The switching frequency reduces to approximately 100KHz at $V_{FB} \leq 0.4V$.

GND - The GND pin provides a return path for all internal control current and acts as a reference to the error amplifier. It is important that it is at the same voltage potential as the load return to ensure proper regulation. Keep current on the ground between the load and the MSK 5044RH to a minimum and use heavy copper traces to minimize voltage drops and regulation error.

SHDN - The SHDN (shutdown) pin has two shutdown functions. The first function disables switching when the voltage on the pin drops below 2.38V (nominal). The second forces a complete shutdown minimizing power consumption when the voltage drops below 0.4V (nominal). Pull this pin high or leave open for normal operation. The 2.38V threshold can be used for UVLO functions by configuring a resistive divider to VIN and GND that holds the pin voltage below 2.38V until VIN rises to the minimum desired voltage.

VOUT - VOUT is the output of the regulator. External capacitance between the VOUT pin and GND is required to maintain stability and minimize output ripple voltage, see "**Selecting The Output Capacitor.**" Provide a low impedance path between VOUT and the load to minimize voltage drops.

SETTING THE OUTPUT VOLTAGE

The output voltage of the MSK 5044RH is set with a single resistor, see Figure 1 (Typical Application Circuit). Select the value of RFB using the formulas below.

$$V_{OUT} = V_{FB} * (1 + R_{FB}/2490)$$

$$R_{FB} = 2490 * ((V_{OUT}/V_{FB}) - 1)$$

Given $V_{FB} = 1.21V$ Nominal

TYPICAL APPLICATION CIRCUIT

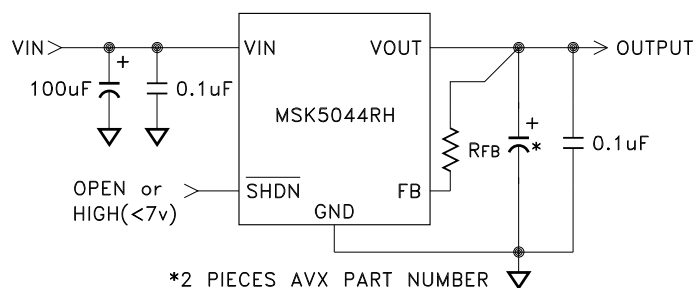

*2 PIECES AVX PART NUMBER
TAZH227K010C(CWR29FC227)

FIGURE 1

SELECTING THE OUTPUT CAPACITOR

The output capacitor filters the ripple current from the internal inductor to an acceptable ripple voltage seen by the load. The primary factor in determining voltage ripple is the ESR of the output capacitor. The voltage ripple can be approximated as follows:

$$V_{P-P} = I_{P-P} * ESR$$

$$\text{Where } I_{P-P} = V_{OUT} * (V_{IN} - V_{OUT}) / (1.65 * V_{IN})$$

The typical ESR range for an MSK 5044RH application is between 0.05 and 0.20 ohm. Capacitors within these ESR ranges typically have enough capacitance value to make the capacitive term of the ripple equation insignificant. The capacitive term of the output voltage ripple lags the ESR term by 90° and can be calculated as follows:

$$V_{P-P}(CAP) = I_{P-P} / (8 * F * C)$$

Where:

C = output capacitance in Farads

F = Switching Frequency in Hertz

Select a capacitor or combination of capacitors that can tolerate the worst-case ripple current with sufficient de-rating. When using multiple capacitors in parallel to achieve ESR and/or total capacitance, sharing of ripple current between capacitors will be approximately equal if all of the capacitors are the same type and preferably from the same lot. Low ESR tantalum capacitors are recommended over aluminum electrolytic. The zero created by the ESR of the capacitor is necessary for loop stability. A small amount of ceramic capacitance close to the load to decouple high frequency is acceptable but it should not cancel the ESR zero.

CURRENT LIMIT

The MSK 5044RH typically current limits at 3.75A. The output voltage will begin to drop when the current limit is reached. If the output voltage drops below 66% of the programmed level the output current limit level will be reduced to protect a shorted or latched up load circuit from a continuous high current condition. The current limit reduction is controlled by the voltage at feedback pin and can be defeated if it is undesired. A simple clamp circuit to prevent the feedback voltage from dropping below a nominal 0.8V will prevent the fold back current condition. The foldback occurs when the feedback voltage drops below 0.8V and the normal in regulation feedback voltage is 1.21V. Clamping the feedback pin to a voltage between 0.9V and 1.1V prevents foldback and allows normal regulation. Clamping the feedback pin will also defeat the frequency shift that occurs when the feedback voltage drops below 0.7V.

TOTAL DOSE RADIATION TEST PERFORMANCE

Radiation performance curves for TID testing will be generated for all radiation testing performed by MS Kennedy. These curves show performance trends throughout the TID test process and are located in the MSK 5044RH radiation test report. The complete radiation test report will be available in the RAD HARD PRODUCTS section on the MSK website.

<http://www.mskennedy.com/store.asp?pid=9951&catid=19680>

TYPICAL PERFORMANCE CURVES

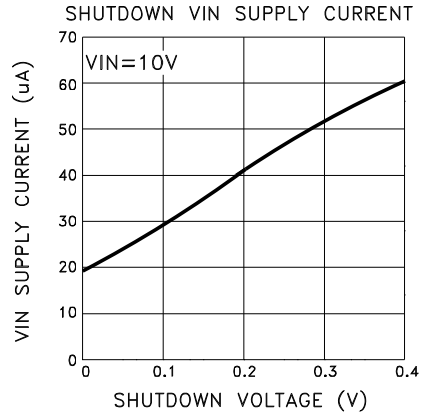
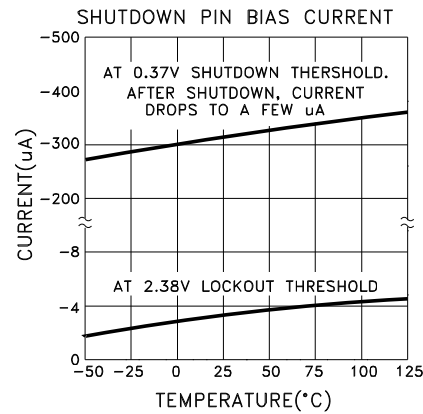
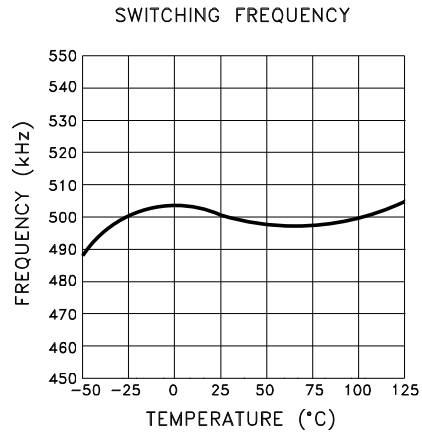
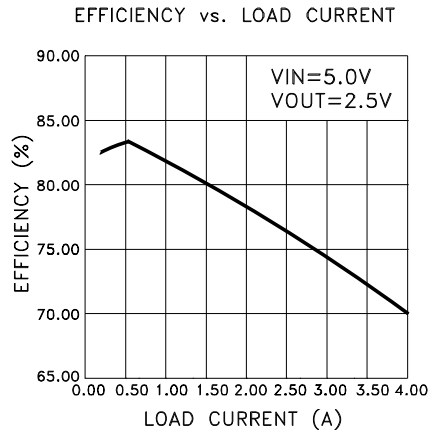
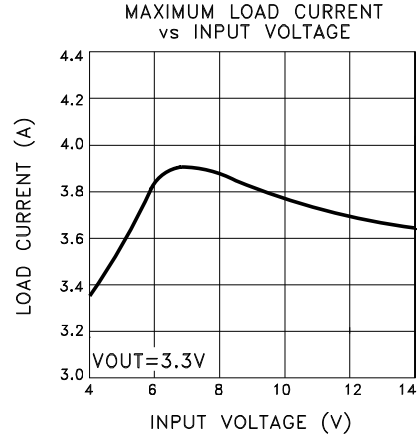
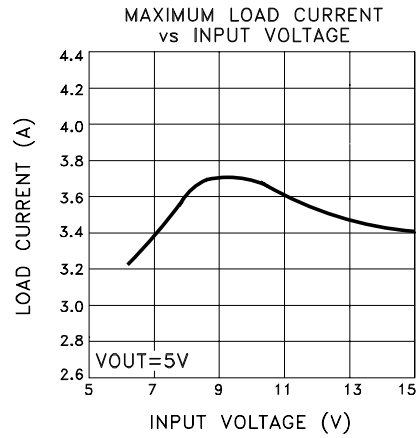
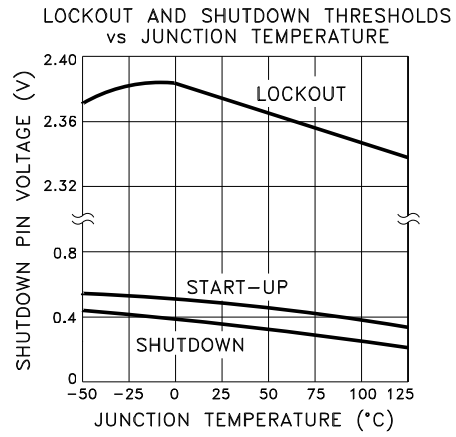
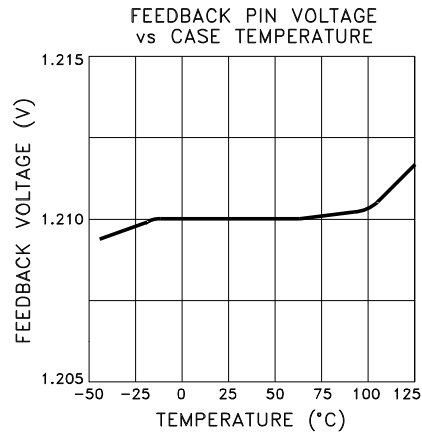

TYPICAL PERFORMANCE CURVES CONT'D

GAIN AND PHASE RESPONSE

The gain and phase response curves are for the MSK typical application circuit and are representative of typical device performance, but are for reference only. The performance should be analyzed for each application to insure individual program requirements are met. External factors such as temperature, input and output voltages, capacitors, etc. all can be major contributors. Please consult factory for additional details.

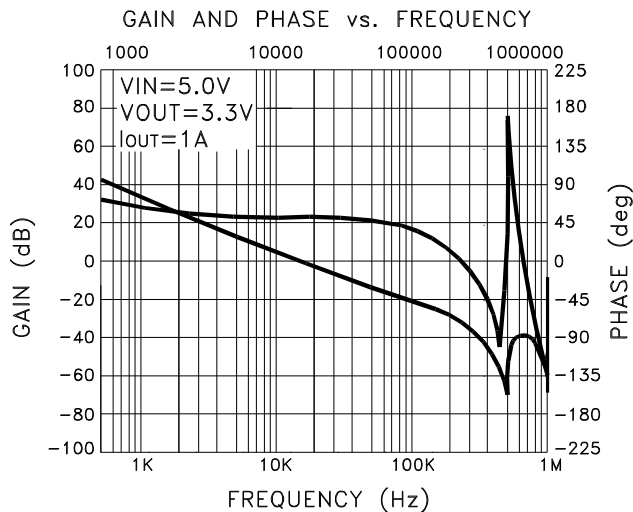
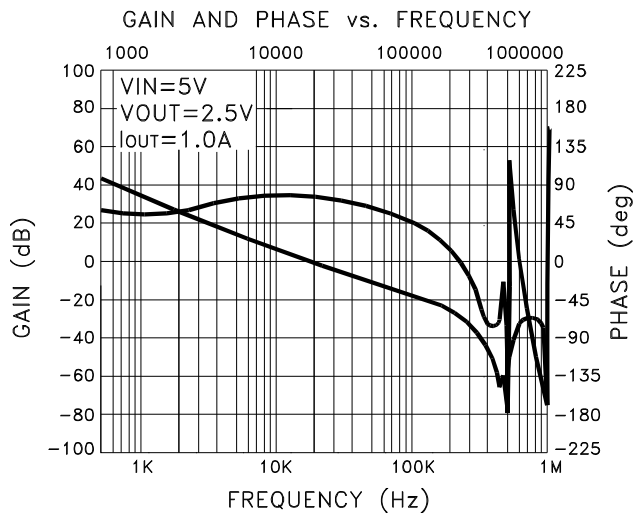
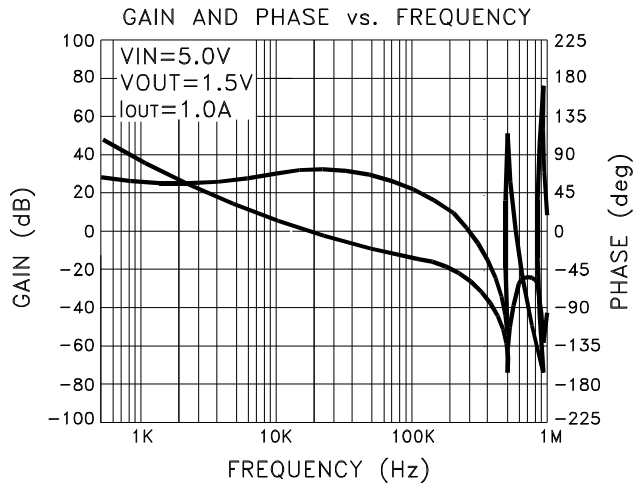

MECHANICAL SPECIFICATIONS

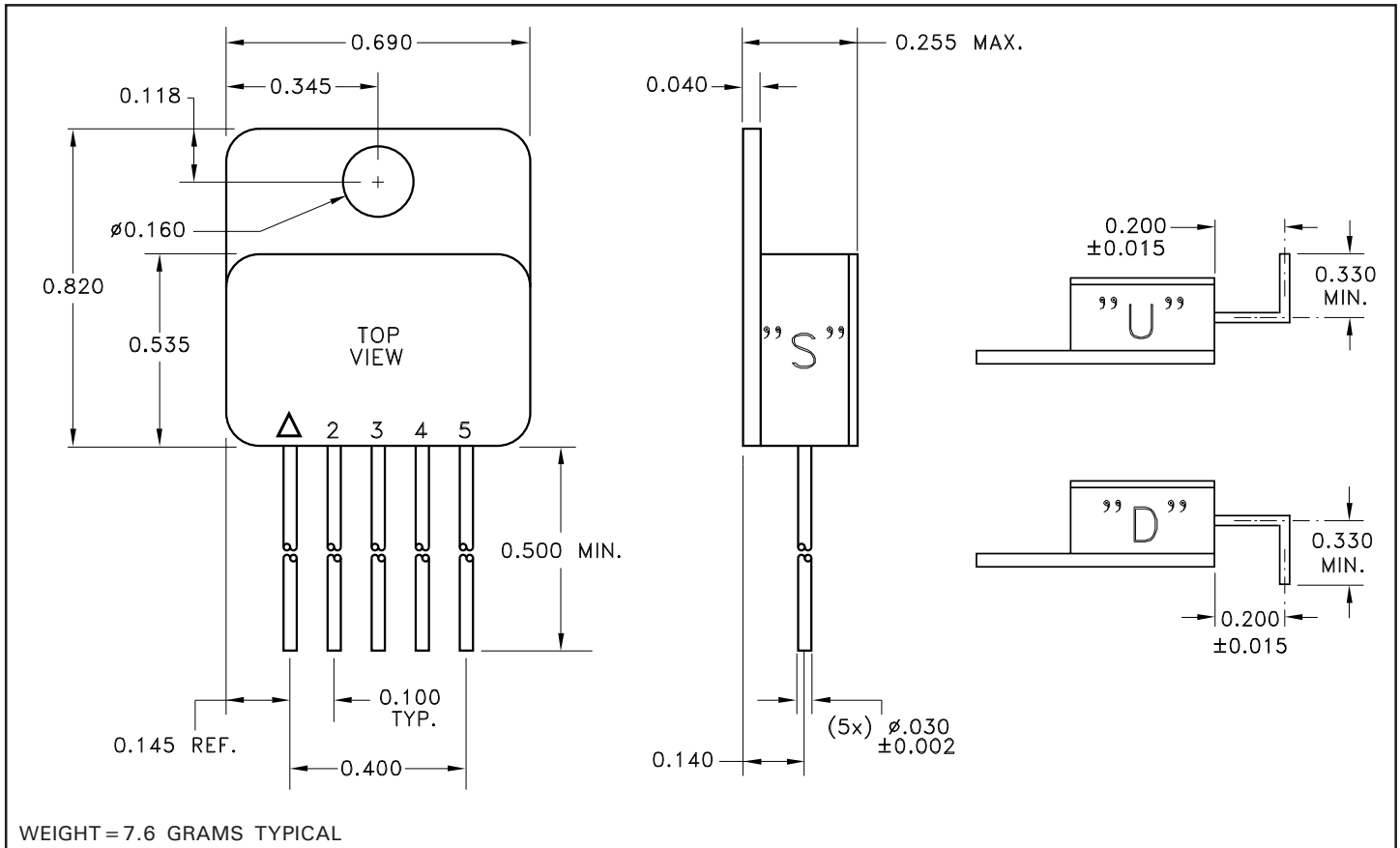

ALL DIMENSIONS ARE ± 0.010 INCHES UNLESS OTHERWISE LABELED.
ESD Triangle indicates pin 1.

ORDERING INFORMATION

MSK5044 K RH U

LEAD CONFIGURATIONS

S = STRAIGHT; U = BENT UP; D = BENT DOWN

RADIATION HARDENED

SCREENING

BLANK = INDUSTRIAL; E = EXTENDED RELIABILITY

H = MIL-PRF-38534 CLASS H; K = MIL-PRF-38534 CLASS K

GENERAL PART NUMBER

The above example is a Class K switching regulator with leads bent up.

M.S. Kennedy Corp.
4707 Dey Road, Liverpool, New York 13088
Phone (315) 701-6751
FAX (315) 701-6752
www.mskennedy.com

The information contained herein is believed to be accurate at the time of printing. MSK reserves the right to make changes to its products or specifications without notice, however, and assumes no liability for the use of its products. Please visit our website for the most recent revision of this datasheet.

Contact MSK for MIL-PRF-38534 Class K and radiation status.