



M.S.KENNEDY CORP.

HIGH VOLTAGE AMPLIFIER

690

4707 Dey Road Liverpool, N.Y. 13088

(315) 701-6751

FEATURES:

- Adjustable High Voltage Power Supply to +75V
- Low Cost TO-3 Package
- High Slew Rate - 2000V/ μ S Typical
- Wide Bandwidth - 30MHz Typical
- Low Transition Time - 20nS Typical at Full Swing

MIL-PRF-38534 CERTIFIED

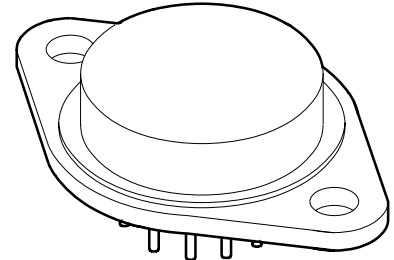

DESCRIPTION:

The MSK 690 is a high voltage differential amplifier designed for use in CRT displays. With the high voltage power supply set to +65 volts, the output voltage of the MSK 690 can swing from +5 volts to +60 volts at a rate of 2000 v/ μ S. The MSK 690 boasts a 30 MHz typical -3dB bandwidth and 20nS typical transition time making it a good candidate for high speed systems. The circuit is packaged in a space efficient, hermetically sealed 8 pin TO-3 to achieve good thermal efficiency and low cost. No isolation washer is necessary when heat sinking this device. The MSK 690 is available in both industrial and military grades.

EQUIVALENT SCHEMATIC

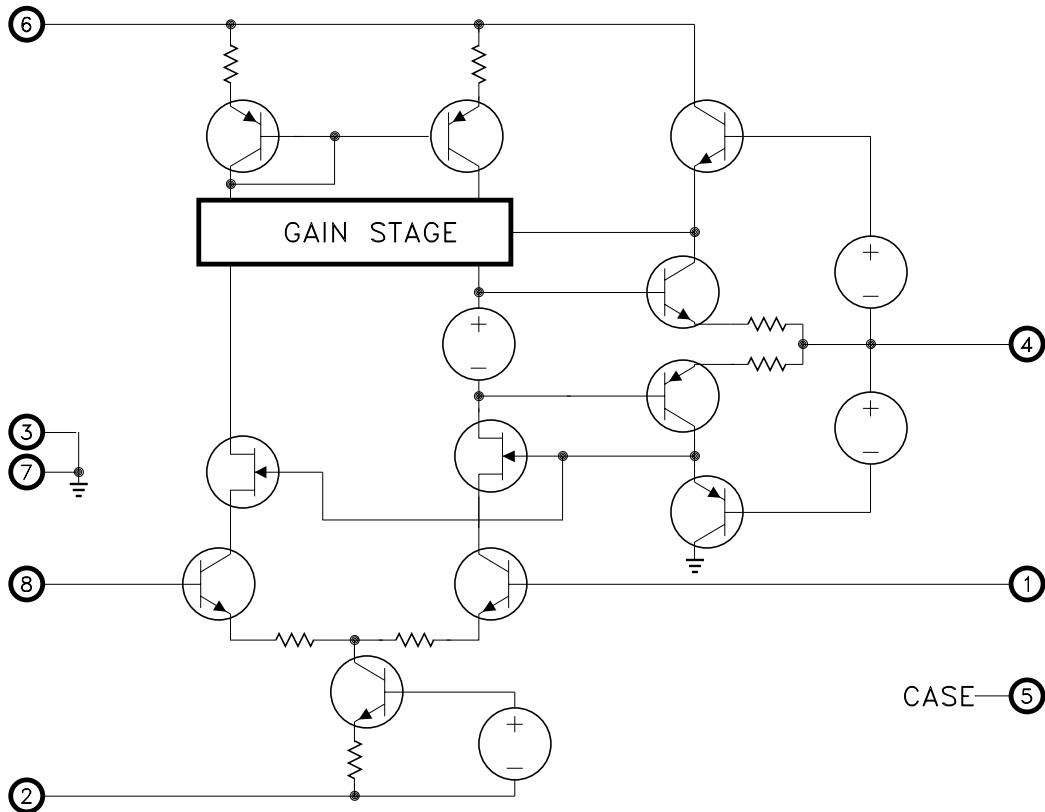

TYPICAL APPLICATIONS

- High Voltage Op-Amp
- CRT Display Driver
- High Voltage ATE Pin Driver
- Level Shifter

PIN-OUT INFORMATION

- | | |
|-------------------|-----------------------|
| 1 Inverting Input | 8 Non-Inverting Input |
| 2 -Vcc | 7 Ground |
| 3 Ground | 6 +VHV |
| 4 Output | 5 Case Connection |

ABSOLUTE MAXIMUM RATINGS

$-V_{CC}$	Supply Voltage	-20V
$+V_{HV}$	High Voltage Supply	+75V
V_{IND}	Differential Input Voltage	15V
I_{OUT}	Output Current	100mA
$R_{\theta JC}$	Thermal Resistance (Output Devices)	42°C/W

T_{ST}	Storage Temperature	-65°C to +150°C
T_{LD}	Lead Temperature (10 Seconds)	300°C
T_C	Case Operating Temperature (MSK690B)	-55°C to +125°C
	(MSK690)	-40°C to +85°C
T_J	Junction Temperature	150°C

ELECTRICAL SPECIFICATIONS

Parameter	Test Conditions ①	Group A Subgroup	MSK690B			MSK690			Units
			Min.	Typ.	Max.	Min.	Typ.	Max.	
STATIC									
Supply Voltage Range ②	$-V_{CC}$	-	-12	-15	-18	-12	-15	-18	V
	$+V_{HV}$	-	+40	+65	+75	+40	+65	+75	V
Quiescent Current	$-V_{CC} = -15V$	1	-	20	27	-	20	27	mA
		2,3	-	20	30	-	-	-	mA
	$+V_{HV} = +65V$	1	-	40	55	-	40	55	mA
		2,3	-	45	60	-	-	-	mA
INPUT									
Input Bias Current	$V_{IN} = 0V$	1	-	±50	±195	-	±50	±250	μA
		2,3	-	±100	±250	-	-	-	μA
Input Offset Current	$V_{IN} = 0V$	1	-	±50	±100	-	±50	±150	μA
		2,3	-	±50	±200	-	-	-	μA
Output Offset Voltage	$V_{OUT} = +50V_{DC}$ Nominal $A_v = 100V/V$	1	-	±0.1	±0.7	-	±0.1	±0.7	V
		2,3	-	±0.1	±1.0	-	-	-	V
OUTPUT									
Output Voltage (High)	$R_L = 10K\Omega$	4	55	60	-	55	60	-	V
Output Voltage (Low)	$R_L = 10K\Omega$	4	-	5.0	7.0	-	5.0	7.0	V
Output Current ②		-	75	100	-	75	100	-	mA
TRANSFER CHARACTERISTICS									
Slew Rate	$R_L = 10K\Omega$	4	1200	2000	-	1200	2000	-	V/μS
Open Loop Voltage Gain ②	$f = 1KHz$	-	55	65	-	55	65	-	dB
Bandwidth (-3dB) ②	$V_o = 24V_{pp}$	-	20	35	-	20	35	-	MHz

NOTES:

- ① Unless otherwise specified, $-V_{CC} = -15V$, $+V_{HV} = +65V$, $A_v = 10V/V$.
- ② Guaranteed by design but not tested. Typical parameters are for reference only.
- ③ Industrial grade devices shall be tested to subgroups 1 and 4 unless otherwise requested.
- ④ Military grade devices ('B' suffix) shall be 100% tested to subgroups 1,2,3 and 4.
- ⑤ Subgroup 5 and 6 testing available upon request.
- ⑥ Subgroup 1,4 $T_C = +25^\circ C$
Subgroup 2,5 $T_C = +125^\circ C$
Subgroup 3,6 $T_A = -55^\circ C$

APPLICATION NOTES

ADJUSTABLE HIGH VOLTAGE POWER SUPPLY CASE CONNECTION

The high voltage power supply of the MSK 690 can be adjusted from +40 volts to +75 volts. To minimize device power dissipation, the +VHV power supply should be decreased as much as possible without causing output signal clipping. The following formula can be used to select a value for +VHV:

$$+VHV = V_{OUTMAX} + 5.0V$$

This will ensure that the transition times are not degraded due to the output transistor temporarily going into saturation.

FEEDBACK CAPACITANCE

The gain range of the MSK 690 is $\pm 5V/V$ to $\pm 100V/V$. When configured for low closed loop gains in the range of $\pm 5V/V$ to $\pm 25V/V$, a small 0.5pF to 2.0pF adjustable capacitor should be placed in parallel with the feedback resistor. This capacitor can be adjusted to tailor overshoot and minimize ringing depending on the load. For closed loop gains greater than $\pm 25V/V$ the user may omit this capacitor without any loss in circuit stability. See the table below labeled "recommended component values" and the typical connection diagram for component selection vs. closed loop gain.

RECOMMENDED COMPONENT VALUES				
Av	-RIN	Rf	+RIN	Cf
-5V/V	510Ω	2.7KΩ	499Ω	0.5-2.0pF
-10V/V	270Ω	2.7KΩ	249Ω	0.5-2.0pF
-50V/V	500Ω	25KΩ	495Ω	N/A
-100V/V	500Ω	50KΩ	499Ω	N/A

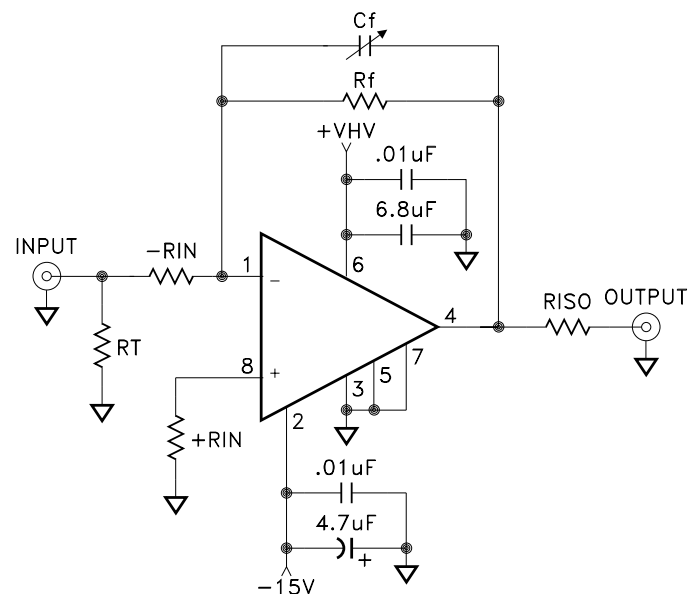

TYPICAL INVERTING CONNECTION DIAGRAM

The case of the MSK 690 is internally connected to pin five of the package. This pin can be left as a no connect but it is recommended that the user connect this pin to ground to reduce noise and improve overall circuit stability.

DECOUPLING AND LAYOUT

Since the MSK 690 is a high voltage amplifier, it is commonly used in high gain configurations. Consequently, any noise introduced into the system through the power supplies will be amplified by the system gain. It is therefore imperative that proper power supply decoupling and printed circuit card layout guidelines are adhered to. Each power supply should be effectively decoupled with a parallel combination of capacitors as shown in the Typical Inverting Connection Diagram. These capacitors should be connected as close as possible to the package pins and lead lengths must be kept to a minimum. On the printed circuit card, the input and output traces should be kept apart whenever possible to avoid localized feedback. The power supply lines should be kept as wide as possible to keep their effective impedance down thereby minimizing pickup.

SOURCE RESISTOR SELECTION

When driving reactive loads, such as the effective capacitance of a cathode ray tube, local oscillations may often occur in the output transistors of the op-amp. To minimize these oscillations, an output source resistor may be added in series with the amplifier output and the capacitive load as seen in the figure below. This R-C combination acts as a snubber network that lowers the high frequency bandwidth. The source resistor is typically in the 10 ohm to 100 ohm range. In exchange for increased overall circuit stability, a minor reduction in amplifier bandwidth may occur. The following formula may be used to approximate the frequency at which the zero will occur on the open loop plot due to the addition of the isolation resistor.

$$f_{ZERO} = 1/(2\pi(R_{ISO} + R_o) C_{LOAD})$$

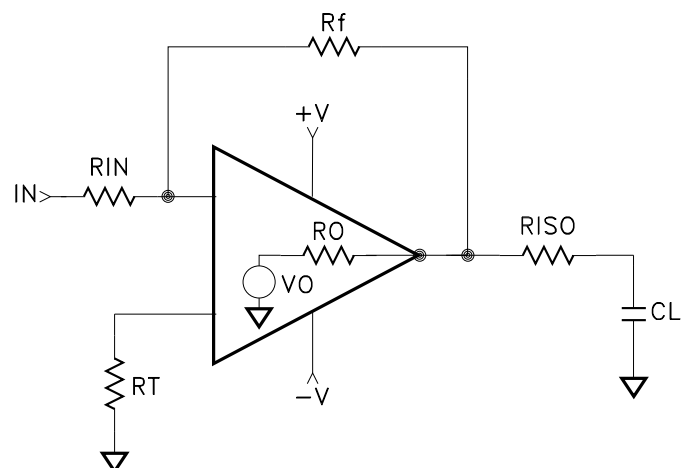

SOURCE RESISTOR CONNECTION

MECHANICAL SPECIFICATIONS

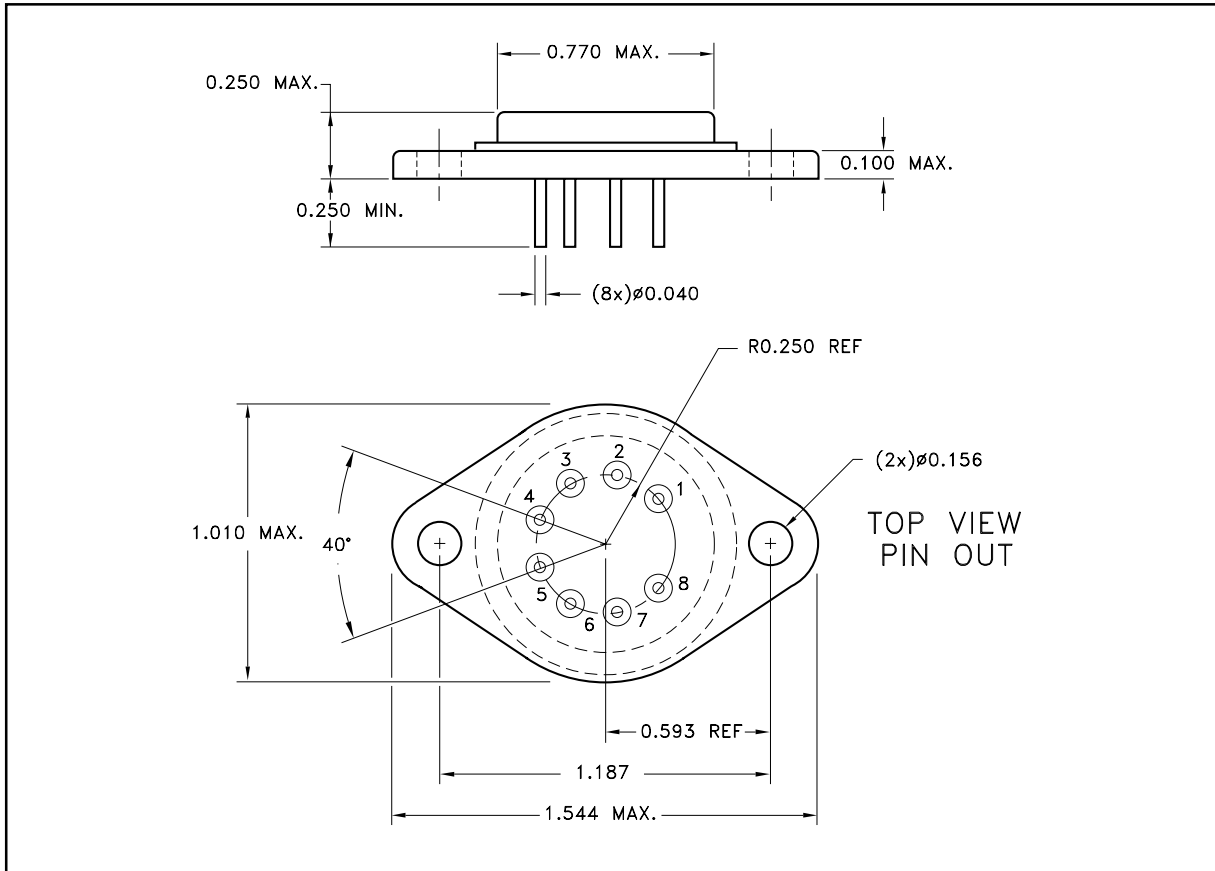

ALL DIMENSIONS ARE ± 0.010 INCHES UNLESS OTHERWISE LABELED.

ORDERING INFORMATION

Part Number	Screening Level
MSK690	Industrial
MSK690B	Military-Mil-PRF-38534

M.S. Kennedy Corp.
 4707 Dey Road, Liverpool, New York 13088
 Phone (315) 701-6751
 FAX (315) 701-6752
www.mskennedy.com

The information contained herein is believed to be accurate at the time of printing. MSK reserves the right to make changes to its products or specifications without notice, however, and assumes no liability for the use of its products.