



M.S.KENNEDY CORP.

# HIGH CURRENT, SUPER LOW DROPOUT ADJUSTABLE VOLTAGE REGULATOR

# 5021

4707 Dey Road Liverpool, N.Y. 13088

(315) 701-6751

**FEATURES:**

- Extremely Low Dropout Voltage: 0.50V @ 20 Amps
- Output Voltage Adjustable from 1.3V to 36V with Two External Resistors
- TTL Level Enable Pin
- Externally Programmable Current Limit
- Low Quiescent Current
- Available Fully Qualified to Mil-PRF-38534
- Output Current to 20 Amps
- Regulation Dropout Fault Pin
- Contact MSK for MIL-PRF-38534 Qualification Status

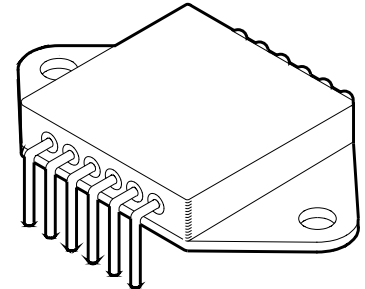

**DESCRIPTION:**

The MSK 5021 is a user adjustable voltage regulator capable of delivering 20 amps to a load with only a 0.5 volt dropout voltage rating. The output voltage is adjustable from 1.3 volts to 36 volts through the selection of two external resistors. Low dropout voltage ratings are achieved by employing a unique parallel MOSFET output pass transistor configuration which drives power dissipation down and efficiency up. Accuracy is guaranteed with a  $\pm 1\%$  voltage tolerance at room temperature that only varies  $\pm 2\%$  over temperature. A TTL level input can be used to enable/disable the device and a regulation dropout Fault pin provides a means of monitoring the output level. The MSK 5021 is packaged in a thermally efficient 12 pin power dip that can be bolted directly to a heat sink.

**EQUIVALENT SCHEMATIC**

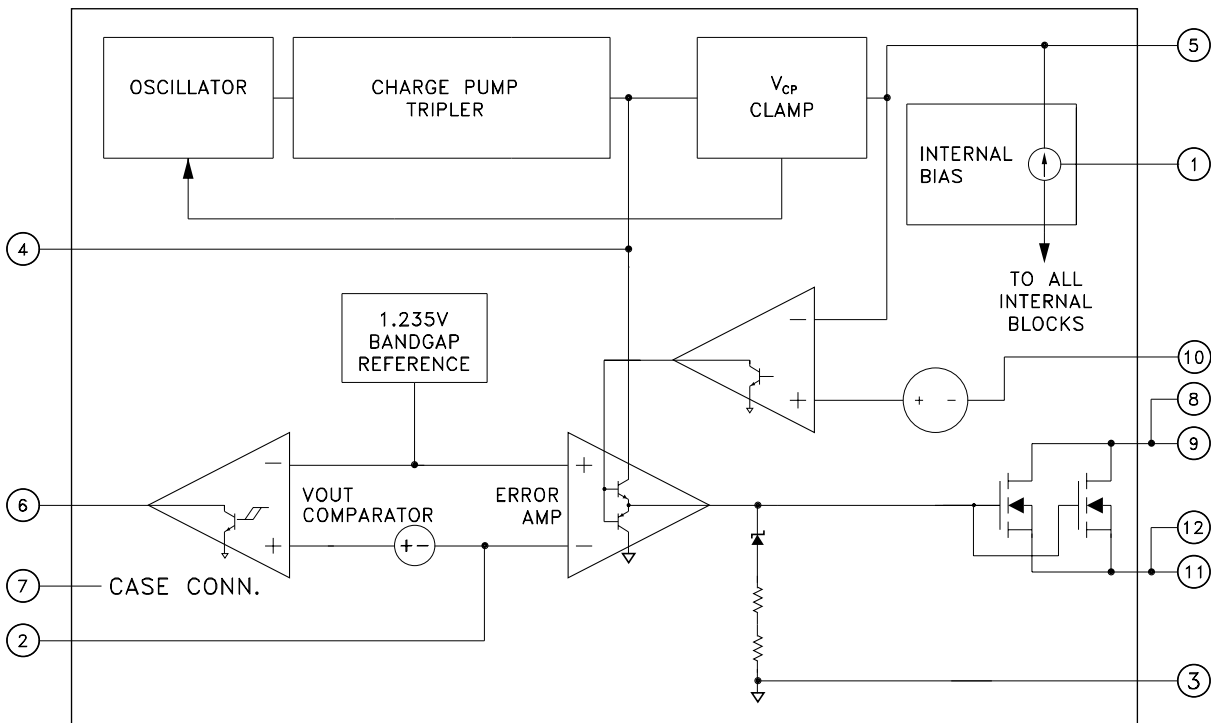

**TYPICAL APPLICATIONS**

- High Efficiency, High Current Linear Regulators
- Adjustable Voltage/Current Regulators
- System Power Supplies
- Switching Power Supply Post Regulators

**PIN-OUT INFORMATION**

1 Enable	12 Output
2 VAdjust	11 Output
3 Ground	10 Sense
4 CPump	9 VSC
5 Input	8 VSC
6 Fault	7 Case Connection

## ABSOLUTE MAXIMUM RATINGS <sup>⑨</sup>

$V_{IN}$  Input Voltage . . . . . 36V  
 $V_{EN}$  Enable Voltage . . . . . -0.3V to 36V  
 $I_{OUT}$  Output Current . . . . . 20A within SOA  
 $T_J$  Junction Temperature . . . . . +175°C

$T_{ST}$  Storage Temperature Range . . . . . -65°C to +150°C  
 $T_{LD}$  Lead Temperature Range . . . . . 300°C  
 (10 Seconds)  
 $T_C$  Case Operating Temperature  
 MSK5021 . . . . . -40°C to +85°C  
 MSK5021B/E Series . . . . . -55°C to +125°C

## ELECTRICAL SPECIFICATIONS

Parameter	Test Conditions <sup>①③</sup>	Group A Subgroup	MSK 5021B/E			MSK 5021			Units
			Min.	Typ.	Max.	Min.	Typ.	Max.	
Input Voltage Range <sup>②</sup>		-	3	-	36	3	-	36	V
Output Voltage Tolerance	$I_{OUT} = 0A$ ; $V_{IN} = V_{OUT} + 1V$	1	-	±0.5	±1.0	-	±0.5	±1.0	%
		2,3	-	±1.0	±2.0	-	-	-	%
Dropout Voltage <sup>②</sup>	$I_{OUT} = 0A$	1	-	0.002	0.010	-	0.002	0.010	V
	$I_{OUT} = 20A$	1	-	0.50	0.75	-	0.5	1.0	V
Load Regulation	$V_{IN} = V_{OUT} + 1V$ $0A \leq I_{OUT} \leq 10A$	1	-	±0.5	±1.0	-	±0.5	±1.0	%
		2,3	-	±0.5	±2.0	-	-	-	%
Line Regulation	$(V_{OUT} + 1V) \leq V_{IN} \leq (V_{OUT} + 15V)$ $I_{OUT} = 0A$	1	-	±0.5	±1.0	-	±0.5	±1.0	%
		2,3	-	±0.5	±1.0	-	-	-	%
Quiescent Current	$V_{EN} = 5V$ ; $V_{IN} = V_{OUT} + 1V$ ; $I_{OUT} = 0A$	1	-	20	30	-	20	30	mA
		2,3	-	20	30	-	-	-	mA
	$V_{EN} = 0V$ ; $V_{IN} = V_{OUT} + 1V$ ; $I_{OUT} = 0A$	1	-	10	50	-	10	50	μA
		2,3	-	10	50	-	-	-	μA
Ripple Rejection <sup>②</sup>	$f = 120Hz$	-	2.4	45	-	-	45	-	dB
Thermal Resistance <sup>②</sup>	Junction to Case @ 125°C	-	-	0.8	1.0	-	0.8	1.0	°C/W
Enable Input Voltage <sup>②</sup>	HIGH	1	-	1.2	-	2.4	1.2	-	V
	LOW	1	-	1.2	0.8	-	1.2	0.8	V
Enable Input Current <sup>②</sup>	HIGH	1	-	20	50	-	20	50	μA
	LOW	1	-	10	25	-	10	25	μA
Output Settling Time <sup>②⑦</sup>	To within 10mV ( $I_{OUT} = 0A$ )	-	-	0.5	-	-	0.5	-	mS
Fault Output Voltage <sup>②⑧</sup>	$I_{FAULT} = 1mA$	HIGH	-	1	$V_{IN}$	-	-	$V_{IN}$	V
		LOW	-	-	0.09	-	-	0.09	V
Fault Output Sink Current Range <sup>②</sup>		-	-	-	10	1	-	10	mA

### NOTES:

- ① Output decoupled to ground using 33μF minimum capacitor and RSC=0Ω unless otherwise specified.
- ② This parameter is guaranteed by design but need not be tested. Typical parameters are representative of actual device performance but are for reference only.
- ③ All output parameters are tested using a low duty cycle pulse to maintain  $T_J = T_C$ .
- ④ Industrial grade and "E" suffix devices shall be tested to subgroup 1 only unless otherwise specified.
- ⑤ Military grade devices ('B' suffix) shall be 100% tested to subgroups 1,2 and 3.
- ⑥ Subgroup 1  $T_A = T_C = +25^\circ C$   
 Subgroup 2  $T_A = T_C = +125^\circ C$   
 Subgroup 3  $T_C = T_C = -55^\circ C$
- ⑦ After application of enable pulse.
- ⑧ Fault pin connected to  $V_{IN}$  through a 5.1KΩ resistor for  $V_{IN} = 5.0V$ .
- ⑨ Continuous operation at or above absolute maximum ratings may adversely effect the device performance and/or life cycle.

## APPLICATION NOTES

### MINIMIZING OUTPUT RIPPLE:

The output voltage ripple of the MSK 5021 voltage regulator can be minimized by placing a filter capacitor from the output to ground. The optimum value for this capacitor may vary from one application to the next and is best determined by experimentation. Transient load response can also be improved by placing a 33uF or larger capacitor directly across the load.

### CASE CONNECTIONS:

The case of the MSK 5021 is connected to pin seven of the package but isolated from the internal circuitry allowing direct attachment of the heat sink to the case. It may be necessary in some applications to ground the case to limit noise or eliminate oscillations on the output. Pin seven can be left as a no connect if the designer chooses.

### LOAD REGULATION:

For best results, the ground pin should be connected directly to the load (see next note). This effectively reduces the ground loop effect and eliminates excessive voltage drop in the sense leg. It is also important to keep the output connection between the regulator and the load as short as possible since this directly affects the load regulation. For example, if 20 gauge wire were used which has a resistance of about .008 ohms per foot, this would result in a drop of 80mV/ft at a load current of 10 amps.

### LOAD CONNECTIONS:

In voltage regulator applications where very large load currents are present, the load connection is very important. The path connecting the output of the regulator to the load must be extremely low impedance to avoid affecting the load regulation specifications. Any impedance in this path will form a voltage divider with the load. The same holds true for the connection from the low end of the load to ground. For best load regulation, the low end of the load must be connected directly to pin 3 of the MSK 5021 and not to a ground plane inches away from the hybrid.

### ENABLE/DISABLE PIN:

The MSK 5021 voltage regulator is equipped with a TTL compatible ENABLE pin. A TTL high level on this pin activates the internal bias circuit and powers up the device. A TTL low level on this pin places the controller in shutdown mode and the device draws only 10µA of quiescent current. This pin can be pulled up to VIN if the enable function is not desired.

### FAULT PIN CONNECTIONS:

Pin 6 of the MSK 5021 is the Fault pin. When the output voltage drops 6% or more below its nominal value, the voltage level on the Fault pin drops to a logic low (typically less than 0.1 volts). This pin can be used to drive a light emitting diode or other external circuitry as long as the current is limited to less than 10.0mA (see typical connection diagram). The Fault pin is an open collector output so the high state output voltage will be equal to the pull up voltage since no current flows under these conditions.

### CPUMP:

For all applications, the user must connect a 1.0uF capacitor from pin 4 directly to ground. This capacitor is part of the circuit which drives the gate of the internal MOSFETS. Approximately three times the voltage seen on the input will appear across this capacitor. Careful attention must be paid to capacitor voltage rating since voltages larger than the power supply are present.

### HEAT SINK SELECTION:

To select a heat sink for the MSK 5021, the following formula for convective heat flow must be used.

Governing Equation:

$$T_j = P_d \times (R_{\theta jc} + R_{\theta cs} + R_{\theta sa}) + T_a$$

WHERE:

$T_j$  = Junction Temperature

$P_d$  = Total Power Dissipation

$R_{\theta jc}$  = Junction to Case Thermal Resistance

$R_{\theta cs}$  = Case to Heat Sink Thermal Resistance

$R_{\theta sa}$  = Heat Sink to Ambient Thermal Resistance

$T_a$  = Ambient Temperature

First, the power dissipation must be calculated as follows:

$$\text{Power Dissipation} = (V_{in} - V_{out}) \times I_{out}$$

Next, the user must select a maximum junction temperature. The absolute maximum allowable junction temperature is 175°C. The equation may now be rearranged to solve for the required heat sink to ambient thermal resistance ( $R_{\theta sa}$ ).

### EXAMPLE:

An MSK 5021 is configured for  $V_{in} = +7V$  and  $V_{out} = +3.3V$ .  $I_{out}$  is a continuous 10A DC level. The ambient temperature is +25°C. The maximum desired junction temperature is 150°C.  $R_{\theta jc} = 0.6^\circ\text{C/W}$  and  $R_{\theta cs} = 0.15^\circ\text{C/W}$  typically.

$$\begin{aligned} \text{Power Dissipation} &= (7V - 3.3V) \times (10A) \\ &= 37 \text{ Watts} \end{aligned}$$

Solve for  $R_{\theta sa}$ :

$$\begin{aligned} R_{\theta sa} &= \left[ \frac{150^\circ\text{C} - 25^\circ\text{C}}{37W} \right] - 0.6^\circ\text{C/W} - 0.15^\circ\text{C/W} \\ &= 2.63^\circ\text{C/W} \end{aligned}$$

In this example, a heat sink with a thermal resistance of no more than 2.63°C/W must be used to maintain a junction temperature of no more than 150°C.

### POWER DISSIPATION:

The output pass transistors in the MSK 5021 are rated to dissipate nearly 200 watts. The limiting factor of this device is effective dissipation of heat generated under such conditions. Careful consideration must be paid to heat dissipation and junction temperature when applying this device.

### CURRENT LIMIT CONNECTIONS:

To implement current limiting, a sense resistor ( $R_{sc}$ ) must be placed from pin 5 to pins 8 and 9 as shown in the typical connection diagram. When the voltage drop across the sense resistor reaches 35mV, the internal control loop limits the output current only enough to maintain 35mV across the sense resistor. The device is not disabled. The following formula may be used to find the correct value of sense resistance:

$$R_{sc} = 35\text{mV}/I_{LIM}$$

If current limit is not required simply connect the Vsc pins directly to the input voltage along with the sense pin. Refer to the typical connection diagram for an illustration.

# TYPICAL PERFORMANCE CURVES

DROPOUT VOLTAGE vs OUTPUT CURRENT

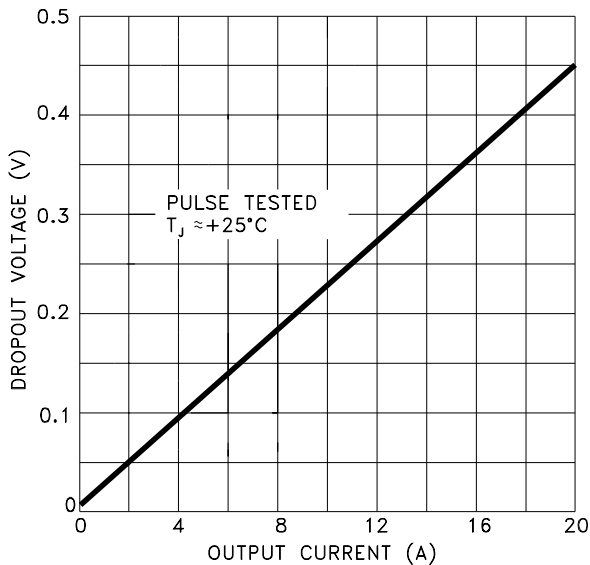

LINE REGULATION

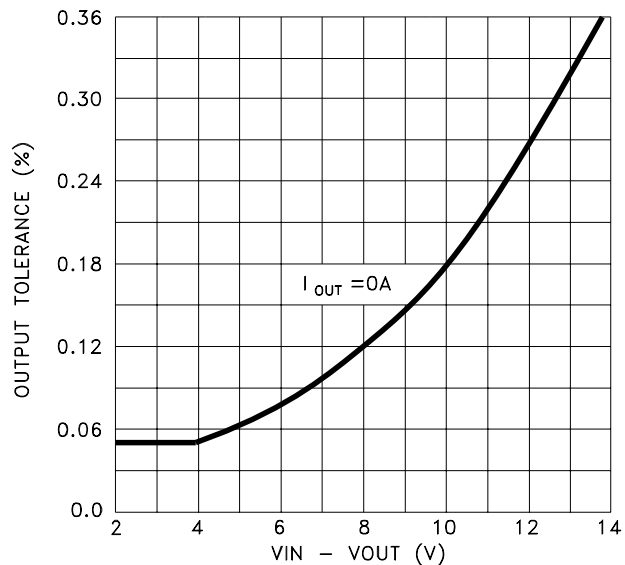

RIPPLE REJECTION vs FREQUENCY

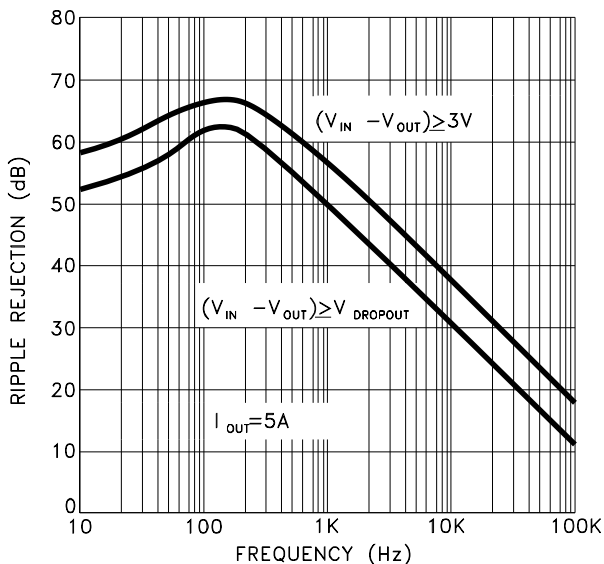

LOAD REGULATION

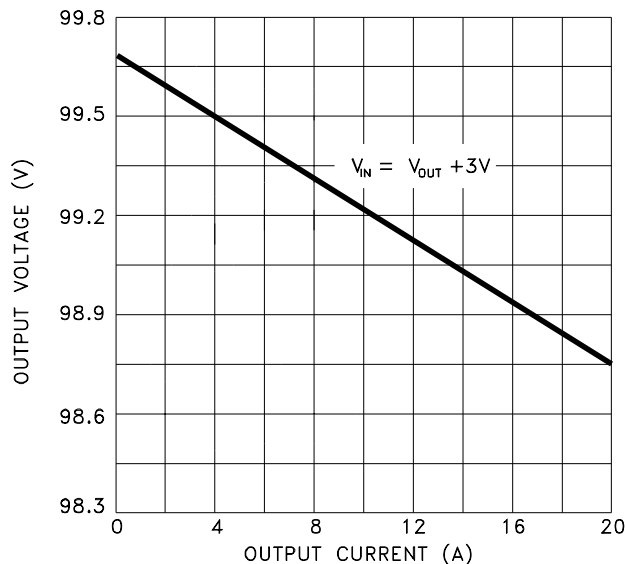

POWER DISSIPATION vs AMBIENT TEMPERATURE vs THERMAL RESISTANCE OF HEAT SINK CHOSEN

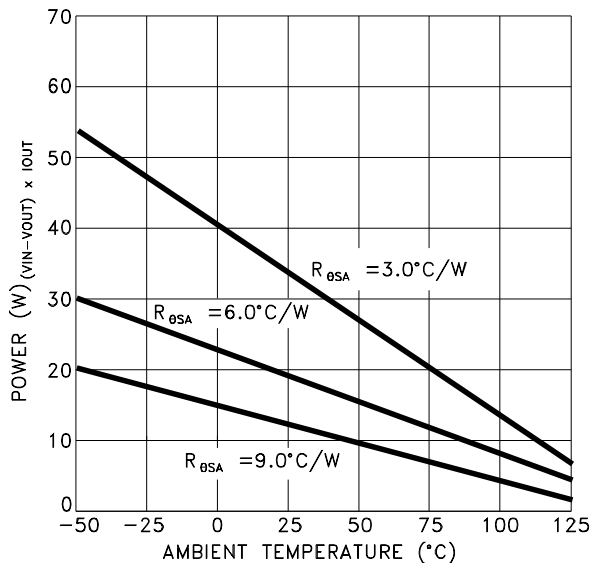

## TYPICAL CONNECTION DIAGRAM

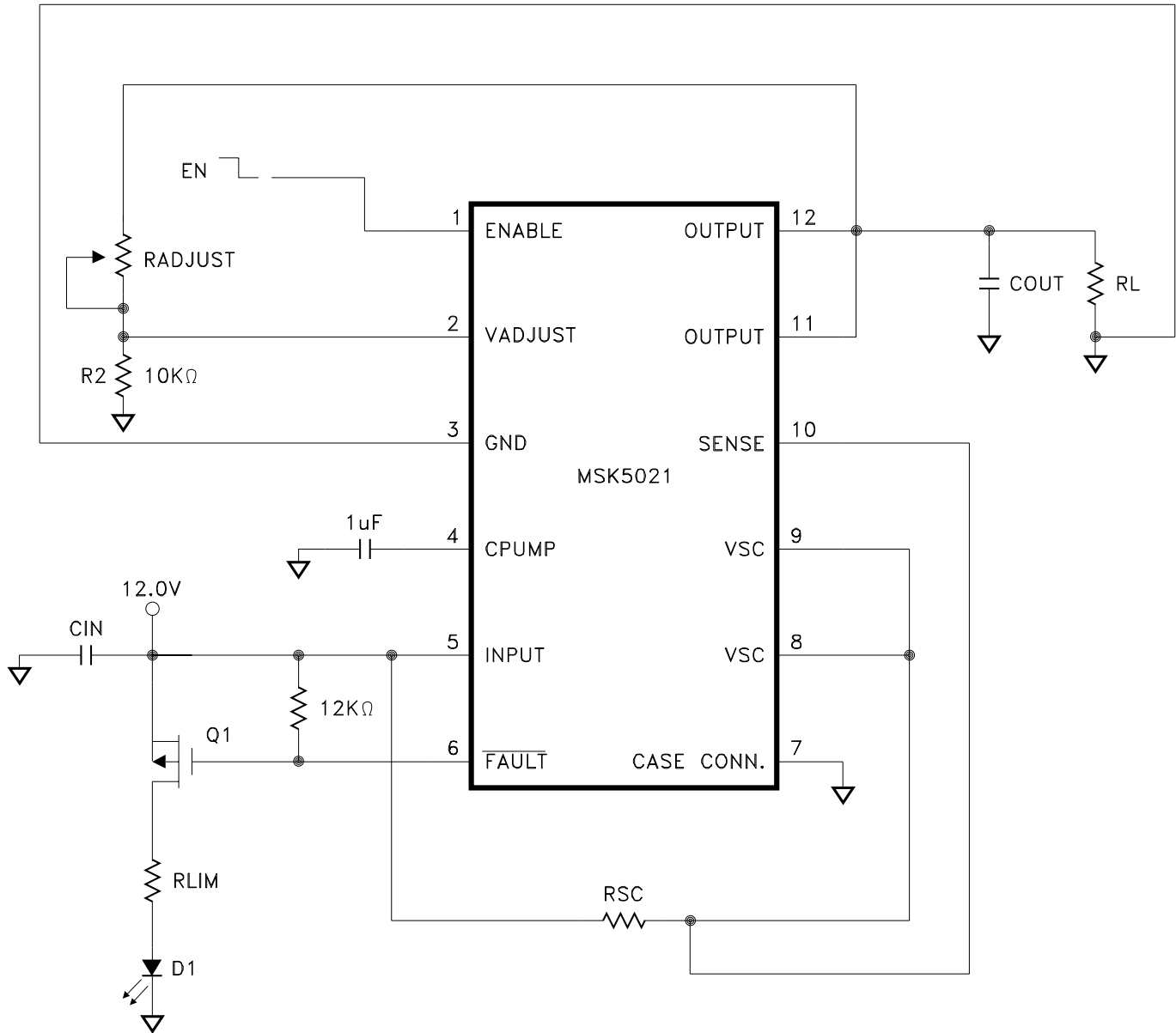

The above connection diagram illustrates an MSK 5021 regulator. Q1 turns on the  $\overline{\text{Fault}}$  L.E.D. when pin 6 of the hybrid drops to a logic low. Current into pin 6 is limited to approximately 1mA by the 12K $\Omega$  resistor from pin 5 to pin 6. The optimum value of capacitance COUT may vary from one application to the next depending on the load applied. 10 $\mu$ F is a good starting point. The ENABLE input is TTL compatible but can be tied to the input voltage when shutdown is not needed. RSC should be selected for the desired current limit. See current limit connections application note.

### OUTPUT VOLTAGE ADJUSTMENT:

The output voltage of the MSK 5021 can be adjusted from +1.3 volts to +36 volts. Refer to the following formula for resistor divider selection. R2 shall be 10K $\Omega$  for all applications.

$$\text{RADJUST} = 1 \times 10^4 ((V_{\text{out}}/1.235)-1)$$

## MECHANICAL SPECIFICATIONS

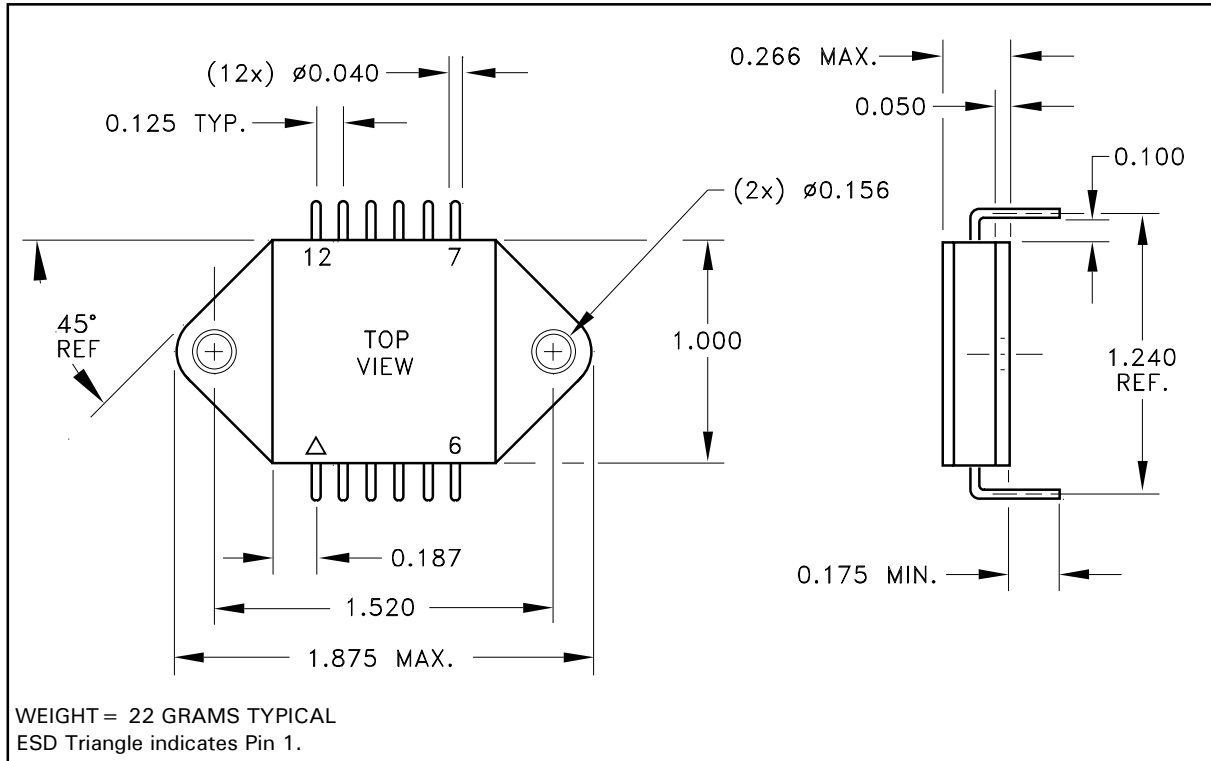

NOTE: ALL DIMENSIONS ARE  $\pm 0.010$  INCHES UNLESS OTHERWISE LABELED.

## ORDERING INFORMATION

Part Number	Screening Level
MSK5021	Industrial
MSK5021E	Extended Reliability
MSK5021B	Mil-PRF-38534 Class H

M.S. Kennedy Corp.  
4707 Dey Road, Liverpool, New York 13088  
Phone (315) 701-6751  
FAX (315) 701-6752  
www.mskennedy.com

The information contained herein is believed to be accurate at the time of printing. MSK reserves the right to make changes to its products or specifications without notice, however, and assumes no liability for the use of its products. Please visit our website for the most recent revision of this datasheet. Contact MSK for MIL-PRF-38534 qualification status.