



M.S.KENNEDY CORP.

10 AMP, 55V, 3 PHASE BRUSHLESS MOTOR SPEED CONTROLLER

4410

4707 Dey Road Liverpool, N.Y. 13088

(315) 701-6751

FEATURES:

- 55 Volt Motor Supply Voltage
- 10 Amp Output Switch Capability
- Shoot-Through/Cross Conduction Protection
- Hall Sensing and Commutation Circuitry on Board
- User Programable Current Limit
- Tach Out-Closed Loop Control
- Available With 3 Lead Configurations

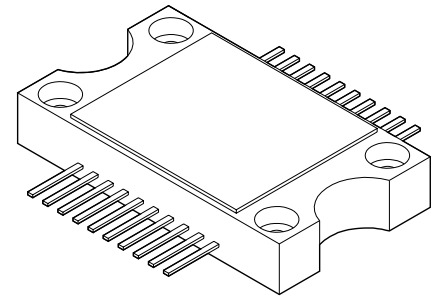

DESCRIPTION:

The MSK 4410 is a complete 3 Phase Brushless Motor Speed Controller in an electrically isolated low cost package. The hybrid is capable of 10 amps of output current and 55 volts of DC bus voltage. Included is all of the bridge drive circuitry, hall sensing circuitry and commutation circuitry. Also included is a user programable current limit circuit and a tachometer circuit for closed loop operation. The MSK 4410 has good thermal conductivity of the output switches due to the isolated substrate/package design that allows direct heat sinking of the hybrid without insulators.

EQUIVALENT SCHEMATIC

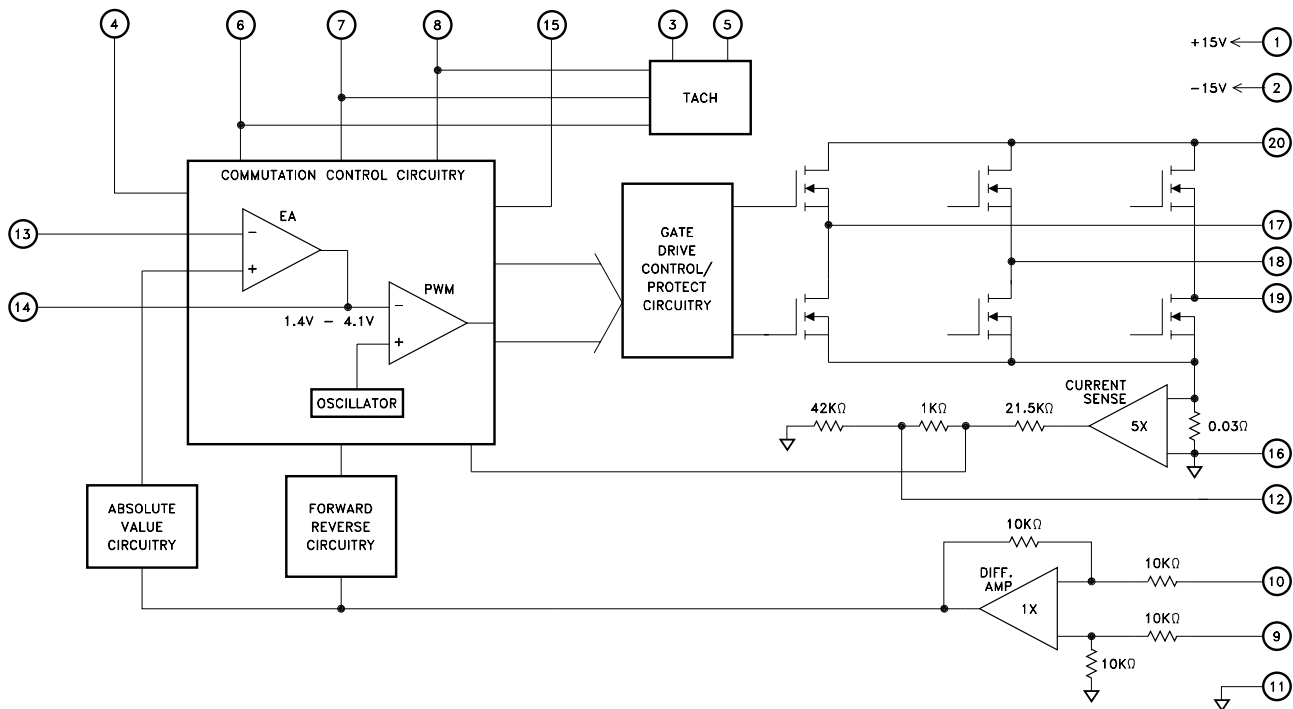

TYPICAL APPLICATIONS

- Fan/Blower Speed Control
- Azimuth/Elevation Antenna Control
- Optical Tracking Control
- Robot Velocity Control

PIN-OUT INFORMATION

1 +15V INPUT	20 V+
2 -15V INPUT	19 C0
3 TACH OUT	18 B0
4 REF OUT	17 A0
5 TACH RC	16 GND
6 HALL A	15 BRAKE
7 HALL B	14 E/A OUT
8 HALL C	13 -E/A
9 SPEED - COMMAND	12 CURRENT LIMIT ADJUST
10 SPEED + COMMAND	11 SIGNAL GND

ABSOLUTE MAXIMUM RATINGS ^③

V+	High Voltage Supply	+ 55V	Θ _{JC}	Thermal Resistance (@ 125° C)	8.8° C/W
V _{IN}	Speed Command (+, -)	± 15VIN	T _{ST}	Storage Temperature Range.	-55° C to + 125° C
V _{IND}	Hall A,B,C,Brake	+ V REF	T _{LD}	Lead Temperature Range.	+ 300° C
I _{OUT}	Continuous Output Current	10A		(10 Seconds)	
I _{PK}	Peak Output Current	15A	T _C	Case Operating Temperature	
+ 15V _{IN}	+ 15 Volt Input Voltage	+ 16V		MSK4410	-40° C to + 85° C
-15V _{IN}	-15 Volt Input Voltage	-16V	T _J	Junction Temperature	+ 150° C

ELECTRICAL SPECIFICATIONS

Parameter	Test Conditions ^①	MSK 4410			Units
		Min.	Typ.	Max.	
PWM					
Clock Frequency		20	25	30	KHz
POWER SUPPLY REQUIREMENTS					
+ 15 Volt Input Current		-	37	60	mA
-15 Volt Input Current		-	8	18	mA
HALL INPUTS					
V _{IL} ^②		-	-	0.8	VOLTS
V _{IH} ^②		3.0	-	-	VOLTS
ANALOG SECTION					
Speed Command Input Range	E/A DC Gain = 1, Positive Command	1.2	-	4.5	VOLTS
Speed Command Input Range	E/A DC Gain = 1, Negative Command	-1.2	-	-4.5	VOLTS
Speed Command Input Current ^②	V _{IN} = 5V	-	-	1.5	mA
REFERENCE OUTPUT VOLTAGE					
Reference Voltage	@ 1mA	5.82	6.24	6.57	VOLTS
ERROR AMP					
Input Offset Voltage ^②		-	0.4	10	mV
Input Offset Current ^②		-	8.0	500	nA
Input Bias Current ^②		-	-46	-1000	nA
Input Common Mode Voltage Range ^②	V _O = 3V, R _L = 15K	0	-	V _{REF}	V
Open-Loop Voltage Gain ^②		70	80	-	db
Input Common Mode Rejection Ratio ^②		55	86	-	db
Power Supply Rejection Ratio ^②		65	105	-	db
OUTPUT SECTION					
Voltage Drop Across Bridge (1 Upper & 1 Lower) ^②	10 AMPS	-	0.8	-	VOLTS
Voltage Drop Across Bridge (1 Upper & 1 Lower) ^②	10 AMPS @ 150° C Junction	-	1.6	1.92	VOLTS
Leakage Current ^②	All switches off, V+ = 44V, 150° C Junction	-	-	750	μA
Diode VSD ^②		-	-	1.6	VOLTS
t _{rr} ^②		-	86	-	nSec
Dead Time ^②		-	2	-	μSec
TACH OUT					
Output Voltage High State	I Source = 5mA	3.60	3.95	4.20	V
Output Voltage Low State	I Sink = 10mA	-	0.25	0.50	V
Output Pulse Width	R/C = 20K/0.01uF	150	200	250	μSec
CURRENT LIMIT					
Current Limit 1 Amp	Current Limit Adjust Pin = Open	0.3	1	1.70	Amps

NOTES:

- ① ± 15V INPUT = ± 15V, V+ = 28V, BRAKE = GND unless otherwise specified.
- ② Guaranteed by design but not tested. Typical parameters are representative of actual device performance but are for reference only.
- ③ Continuous operation at or above absolute maximum ratings may adversely effect the device performance and/or life cycle.

APPLICATION NOTES

MSK 4410 PIN DESCRIPTIONS

V+ - is the power connection from the hybrid to the bus. The external wiring to the pin should be sized according to the RMS current required by the motor. This pin should be bypassed by a high quality monolithic ceramic capacitor for high frequencies and enough bulk capacitance to keep the V+ power supply from drooping.

AØ OUT, BØ OUT, CØ OUT-are the connections to the motor phase windings from the bridge output. The wiring to these pins should be sized according to the motor current requirements. There are no internal short circuit protection provisions for these output pins in the hybrid. Shorts to V+ or ground from these pins must be avoided or the bridge will be destroyed.

GND-is the power return connection from the hybrid to the bus. All ground returns internal to the hybrid connect to this point in a star configuration. All external ground connections to this point should be made in a similar fashion. The V+ capacitors should be returned to this pin as close as possible. Wire sizing to this pin connection should be made according to the required current.

SIG GND - is the ground pin that connects to the ground plane for all low power circuitry inside the device.

+ 15 V INPUT -is the pin for applying + 15 volts to run the low power control circuitry inside the hybrid. This pin should be bypassed to the signal ground pin using a high quality 10µF tantalum capacitor and a 0.1µF ceramic capacitor as close to these pins as possible.

-15 V INPUT - is the pin for applying -15 volts to run the low power control circuitry inside the hybrid. This pin should be bypassed to the signal ground pin using a high quality 10µF tantalum capacitor and a 0.1µF ceramic capacitor as close to these pins as possible.

BRAKE - is the pin for commanding the output bridge into a motor brake mode. When this pin is taken low, normal operation of the hybrid proceeds. When this pin is taken high, the three high side switches in the bridge turn off and the three lowside switches turn fully on. This will cause rapid deceleration of the motor and will cease motor operation until taken low again. The pin left open is internally pulled high.

HALL A, B & C - are the hall input pins from the hall devices in the motor. These pins are internally pulled up to 6.25 volts. The halls reflect a 120/240 degree commutation scheme.

TACH RC - is used to set the tach out pulse width. This is done by connecting a resistor from this pin to the REF OUT pin and a capacitor from the pin to the signal ground. Selection of these components is based on the desired maximum motor speed. (See TACH RC component selection)

TACH OUT - is connected to the -E/A pin through a resistor when using the speed controller in a closed loop configuration..

-E/A - is the error amp inverting input connection. It is brought out to allow various loop compensation circuits to be connected between this and E/A out.

E/A OUT - this is the loop error amp output connection. It is brought out for allowing various loop compensation circuits to be connected between this and -E/A.

REF OUT - is a 6.25 volt regulated output that can be used to power the hall devices in various motors. Up to 15 milliamps of current is available.

CURRENT LIMIT ADJUST - is used to adjust the output current limit. The pin, if left open will limit the output current to about 1 amp. The pin, taken to ground will limit the current to about 15 amps. A resistor from the pin to ground will yield current limits in between. (See Current Limit Adjust)

SPEED COMMAND (+, -) - are differential inputs for controlling the motor speed. With a positive voltage command the motor will operate in the forward direction and with a negative command the motor will operate in the reverse direction. The maximum operational command voltage should be ± 5 volts.

COMMUTATION TRUTH TABLE

HALL SENSOR PHASING			SPEED COMMAND = POS.			SPEED COMMAND = NEG.		
120°			AØ	BØ	CØ	AØ	BØ	CØ
HALL A	HALL B	HALL C	AØ	BØ	CØ	AØ	BØ	CØ
1	0	0	H	-	L	L	-	H
1	1	0	-	H	L	-	L	H
0	1	0	L	H	-	H	L	-
0	1	1	L	-	H	H	-	L
0	0	1	-	L	H	-	H	L
1	0	1	H	L	-	L	H	-
1	1	1	-	-	-	-	-	-
0	0	0	-	-	-	-	-	-
X	X	X	L	L	L	L	L	L

1 = High Level H = SOURCE
 0 = Low Level L = SINK
 X = Don't Care - = OPEN

APPLICATION NOTES CONTINUED

BUS VOLTAGE FILTER CAPACITORS

The size and placement of the capacitors for the DC bus has a direct bearing on the amount of noise filtered and also on the size and duration of the voltage spikes seen by the bridge. What is being created is a series RLC tuned circuit with a resonant frequency that is seen as a damped ringing every time one of the transistors switches. For the resistance, wire resistance, power supply impedance and capacitor ESR all add up for the equivalent lumped resistance in the circuit. The inductance can be figured at about 30 nH per inch from the power supply. Any voltage spikes are on top of the bus voltage and the back EMF from the motor. All this must be taken into account when designing and laying out the system. If everything has been minimized, there is another solution. A second capacitance between 5 and 10 times the first capacitor and it should either have some ESR or a resistor can be added in series with the second capacitor to help damp the voltage spikes.

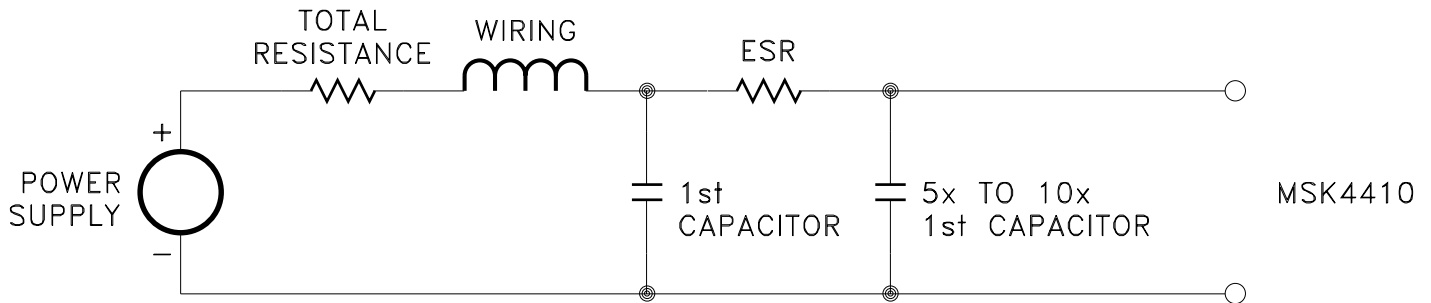

Be careful of the ripple current in all the capacitors. Excessive ripple current, beyond what the capacitors can handle, will destroy the capacitors.

INPUT VOLTAGE FILTER CAPACITORS

It is recommended that about 10 μF of capacitance (tantalum electrolytic) for bypassing the + and -15V power supplies be placed as close to the module pins as practical. Adding ceramic bypass capacitors of about 0.1 μF to 1 μF will aid in suppressing noise transients.

GENERAL LAYOUT

Good PC layout techniques are a must. Ground plane for the analog circuitry must be used and should be tied back to the SIG GND. Ground plane for the power circuitry should be tied back to the GND pin, pin 16. Pin 16 should be connected to pin 11 external to the hybrid by a single thick trace. This will connect the two ground planes together.

LOW POWER STARTUP

When starting up a system utilizing the MSK 4410 for the first time, there are a few things to keep in mind. First, because of the small size of the module, short circuiting the output phases either to ground or the DC bus will destroy the bridge. The current limiting and control only works for current actually flowing through the bridge. The current sense resistor has to see the current in order for the electronics to control it. If possible, for startup use a lower voltage and lower current power supply to test out connections and the low current stability. With a limited current supply, even if the controller locks up, the dissipation will be limited. The ± 15 volt power should be applied prior to applying the V+ voltage.

APPLICATION NOTES CONTINUED

TACH RC COMPONENT SELECTION

For a given maximum motor speed, the tach output has a maximum pulse width. For example, if a maximum motor speed of 3000 RPM were desired and the permanent magnet on the rotor of the motor being used has two pairs of poles, each mechanical revolution would cause each hall effect sensor to deliver two pulses. The three sensors would generate six pulses. The MSK4410 tachometer would generate 12 pulses, one for each rising and falling edge of the sensor pulses. If a maximum motor speed in the example were desired, this would be 50 revolutions per second. The tachometer will be producing 600 pulses per second or have a frequency of 600Hz. Therefore, the maximum pulse width would have to be less than 1.66 milliseconds. Figure one can be used to select component values to achieve the desired pulse width.

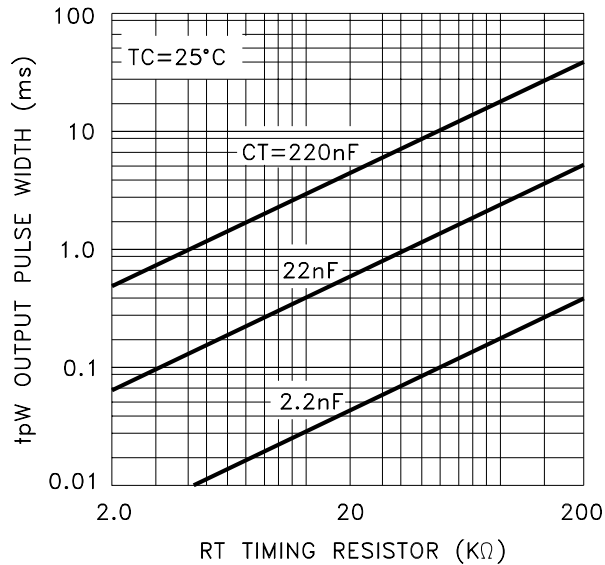

FIGURE 1

CURRENT LIMIT ADJUST

With the current limit adjust pin (pin 12) left open, the current will be limited to 1 amp \pm 0.7 amps. If a current limit of more than 1 amp but less than 15 amps is desired, a resistor between the pin and ground can be used to set a different limit. Figure two can assist in the selection of the resistor value for this purpose.

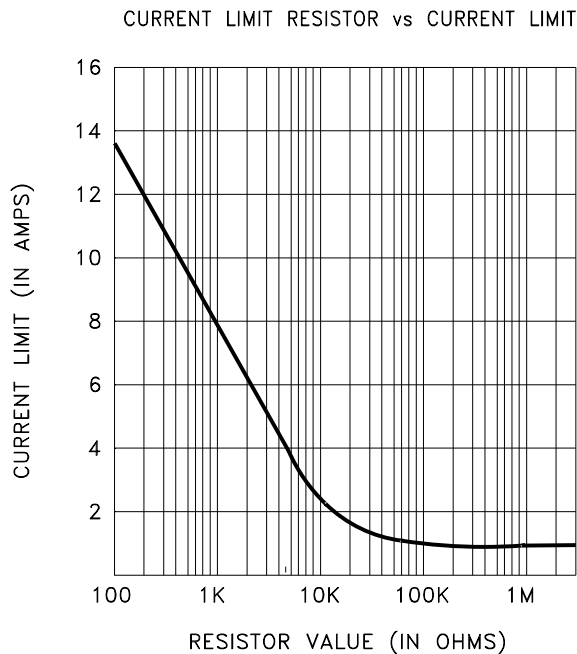
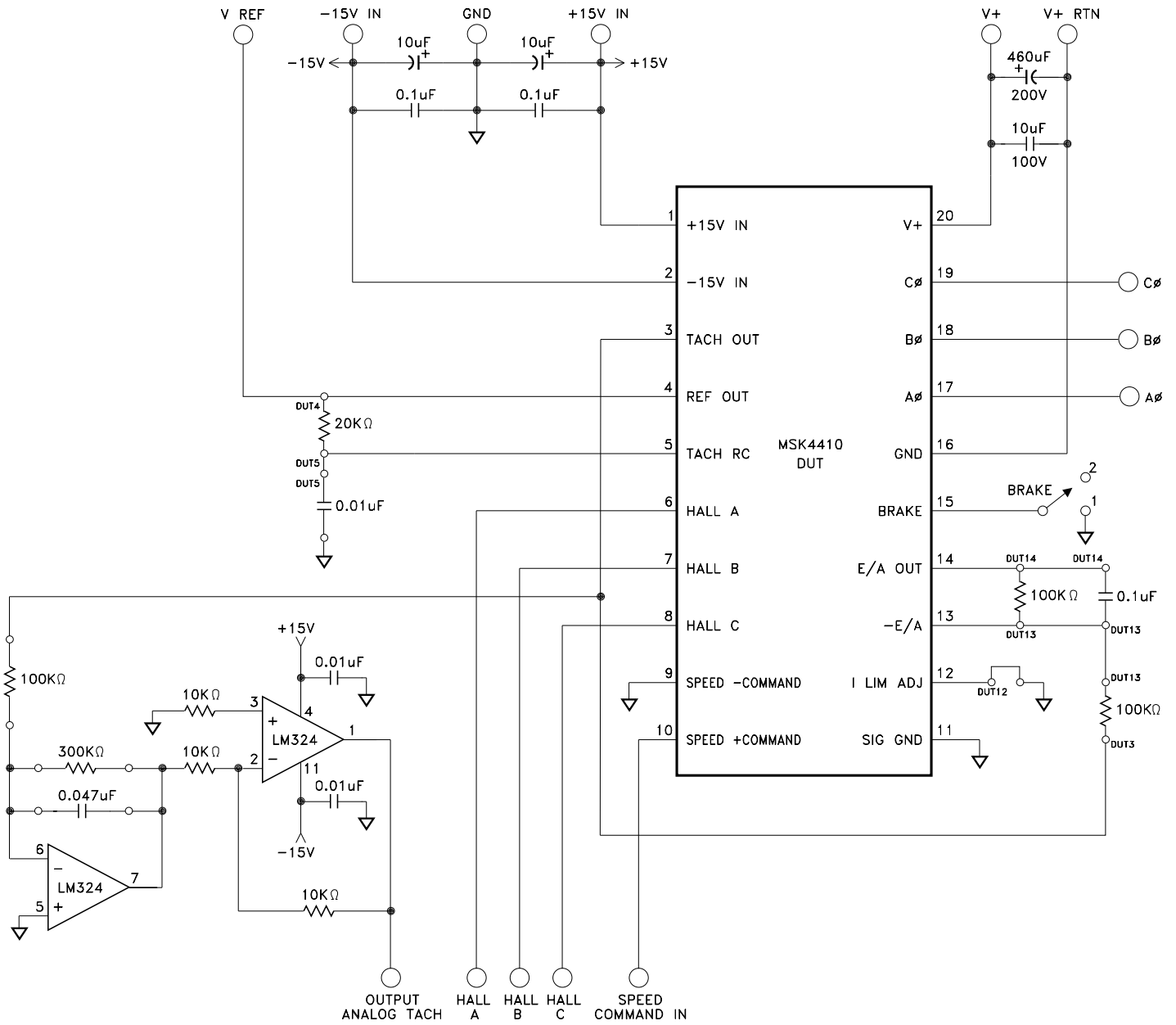
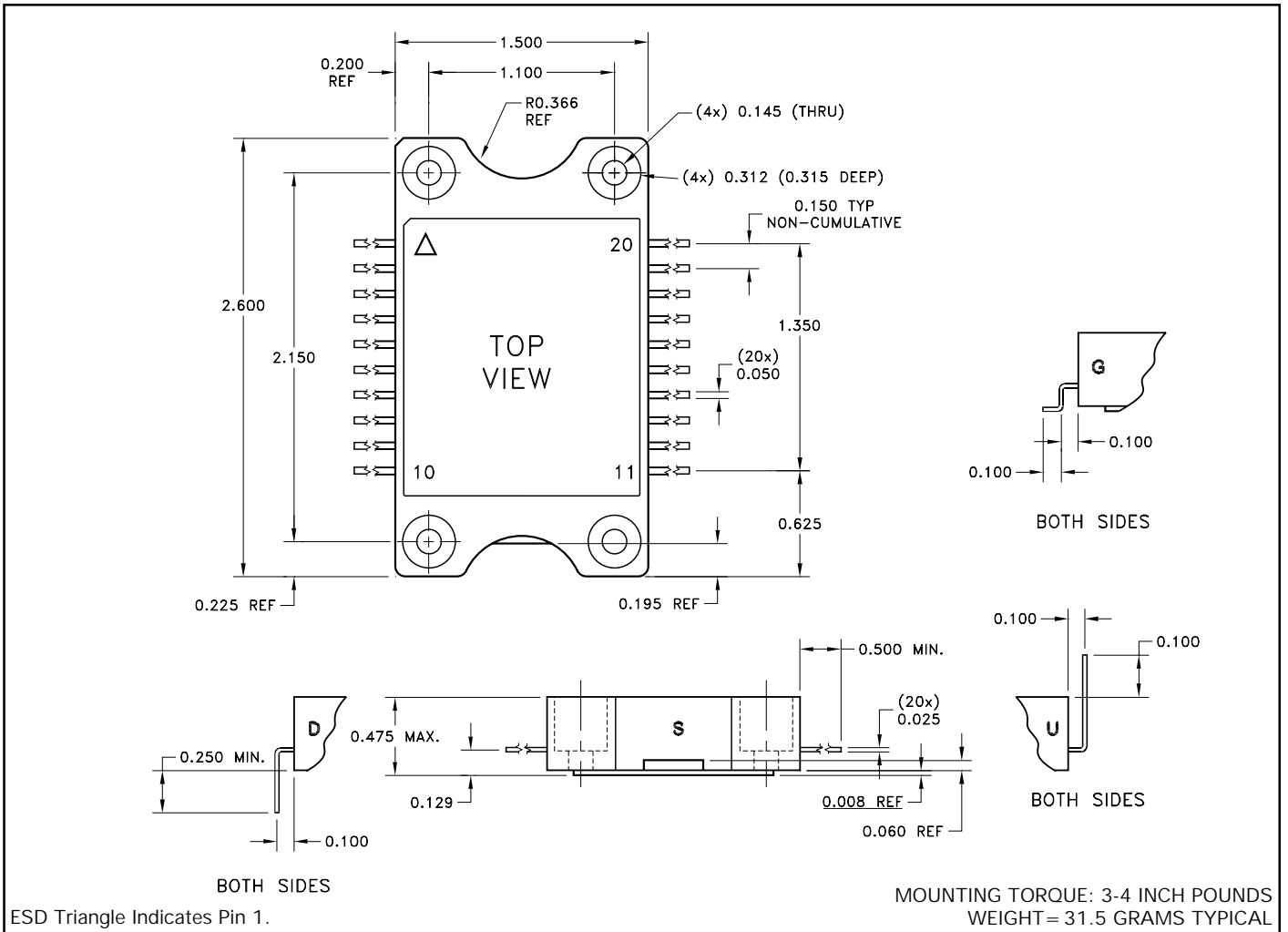

FIGURE 2

MSK4410 TYPICAL APPLICATION CIRCUIT



MECHANICAL SPECIFICATIONS



NOTE: ALL DIMENSIONS ARE INCHES UNLESS OTHERWISE LABELED.

ORDERING INFORMATION

Part Number	Screening Level	Lead Configuration
MSK4410S	Industrial	Straight
MSK4410D	Industrial	Down
MSK4410U	Industrial	Up
MSK4410G	Industrial	Gull Wing

M.S. Kennedy Corp.
4707 Dey Road Liverpool, New York 13088
Phone (315) 701-6751
FAX (315) 701-6752
www.mskennedy.com

The information contained herein is believed to be accurate at the time of printing. MSK reserves the right to make changes to its products or specifications without notice, however, and assumes no liability for the use of its products. Please visit our website for the most recent revision of this datasheet.