



M.S.KENNEDY CORP.

10 AMP, 500V, 3 PHASE IGBT BRUSHLESS MOTOR CONTROLLER

4370

4707 Dey Road Liverpool, N.Y. 13088

(315) 701-6751

FEATURES:

- 500 Volt Motor Supply Voltage
- 10 Amp Output Switch Capability
- Shoot-Through/Cross Conduction Protection
- Hall Sensing and Commutation Circuitry on Board
- "Real" Four Quadrant Torque Control Capability
- Good Accuracy Around the Null Torque Point
- Hermetic Package Design for High Voltage Isolation Plus Good Thermal Transfer
- 60° / 120° Phasing Selectable
- Contact MSK for MIL-PRF-38534 Qualification Status

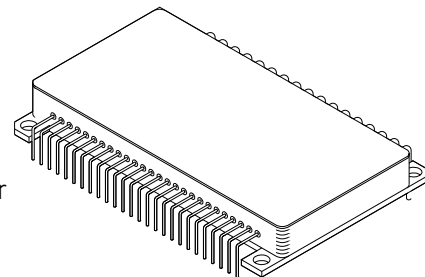

DESCRIPTION:

The MSK 4370 is a complete 3 Phase IGBT Bridge Brushless Motor Control System in a convenient isolated baseplate package. The hybrid is capable of 10 amps of output current and 500 volts of DC bus voltage. It has the normal features for protecting the bridge. Included is all the bridge drive circuitry, hall sensing circuitry, commutation circuitry and all the current sensing and analog circuitry necessary for closed loop current mode (torque) control. When PWM'ing, the transistors are modulated in locked anti-phase (complementary) mode for the tightest control and the most bandwidth. Provisions for applying different compensation schemes are included. The MSK 4370 has good thermal conductivity of the IGBT's due to a hermetic isolated package design that allows direct heat sinking of the hybrid without insulators.

BLOCK DIAGRAM

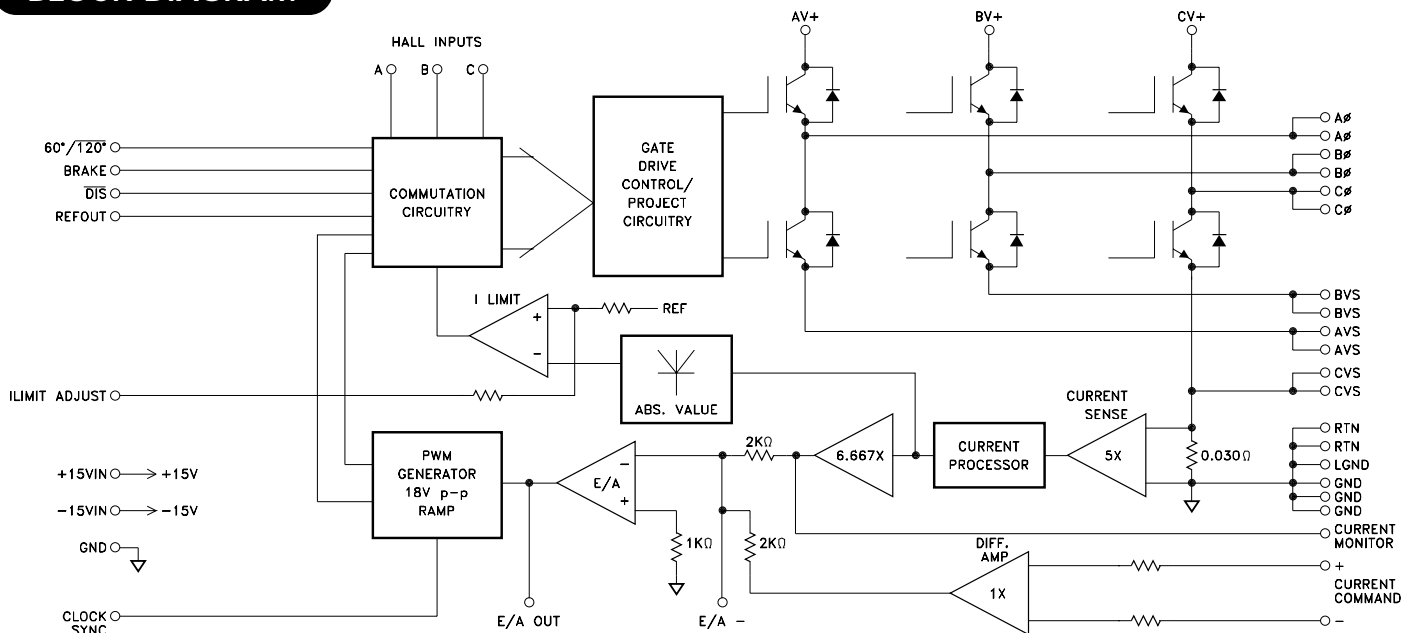

TYPICAL APPLICATIONS

- 3 Phase Brushless DC Motor Control
- Servo Control
- Fin Actuator Control
- Gimbal Control
- AZ-EL Control

PIN-OUT INFORMATION

| | | | |
|--------------|----------------------|---------|--------|
| 1 REFOUT | 12 E/A OUT | 23 GND | 34 BVS |
| 2 HALL A | 13 E/A- | 24 NC | 35 BVS |
| 3 HALL B | 14 GND | 25 NC | 36 BØ |
| 4 HALL C | 15 + CURRENT COMMAND | 26 LGND | 37 BØ |
| 5 60/120 | 16 -CURRENT COMMAND | 27 RTN | 38 BV+ |
| 6 BRAKE | 17 +15 VIN | 28 RTN | 39 AVS |
| 7 CLOCK SYNC | 18 CURRENT MONITOR | 29 CVS | 40 AVS |
| 8 DIS | 19 -15 VIN | 30 CVS | 41 AØ |
| 9 GND | 20 NC | 31 CØ | 42 AØ |
| 10 NC | 21 NC | 32 CØ | 43 AV+ |
| 11 NC | 22 ILIMIT ADJUST | 33 CV+ | |

ABSOLUTE MAXIMUM RATINGS ^⑦

| | |
|--|-----------------|
| High Voltage Supply ^⑧ | 500V |
| Current Command Input | ± 13.5V |
| Logic Inputs | -0.2V to REFOUT |
| REFOUT External Load | 15 mA |
| E/A OUT External Load | 5 mA |
| Clock SYNC Input | -0.2V to + 15V |
| Continuous Output Current | 10 Amps |
| Continuous Output Current @ 125° C Case. | 5 Amps |
| Peak Output Current | 15 Amps |

| | |
|---|--------------------------|
| R _{θJC} Thermal Resistance (Output Switches) | 0.66° C/W |
| T _{ST} Storage Temperature Range | -65° C to + 150° C |
| T _{LD} Lead Temperature Range | + 300° C (10 Seconds) |
| T _C Case Operating Temperature (MSK 4370) | -40° C to + 85° C |
| (MSK 4370H/E) | -55° C to + 125° C |
| T _J Junction Temperature | + 150° C |

ELECTRICAL SPECIFICATIONS

| Parameter | Test Conditions | Group A Subgroup ^{④ ⑤} | MSK 4370H/E ^⑤ | | | MSK 4370 ^② | | | Units |
|---|--|---------------------------------|--------------------------|------|---------|-----------------------|------|---------|--------|
| | | | Min. | Typ. | Max. | Min. | Typ. | Max. | |
| INPUT CURRENT | | | | | | | | | |
| + 15 VIN | Output PWM'ing Current Command= 0 Volts | 1 | - | 89 | 150 | - | 89 | 150 | mA |
| | | 2 | - | 83 | 150 | - | - | - | mA |
| | | 3 | - | 106 | 150 | - | - | - | mA |
| -15 VIN | Output PWM'ing Current Command= 0 Volts | 1 | - | 24 | 60 | - | 24 | 60 | mA |
| | | 2 | - | 26 | 60 | - | - | - | mA |
| | | 3 | - | 23 | 60 | - | - | - | mA |
| PWM Clock Frequency | Free Running | 4 | 14 | 17 | 20 | 14 | 17 | 20 | KHz |
| | | 5,6 | 14 | 17 | 20 | - | - | - | KHz |
| CLOCK SYNC INPUT | | | | | | | | | |
| VIL ^① | | - | - | - | 2.5 | - | - | 2.5 | V |
| VIH ^① | | - | 12.5 | - | - | 12.5 | - | - | V |
| Duty Cycle ^① | | - | 10 | - | 90 | 10 | - | 90 | % |
| Sync Frequency ^① | | - | Clock+0 | - | Clock+3 | Clock+0 | - | Clock+3 | KHz |
| LOGIC INPUTS (Hall A,B,C,Brake,60°/120°) | | | | | | | | | |
| VIL ^① | | - | - | - | 0.8 | - | - | 0.8 | V |
| VIH ^① | | - | 3.0 | - | - | 3.0 | - | - | V |
| DIS | | | | | | | | | |
| VIL ^① | | - | - | - | 2.5 | - | - | 2.5 | V |
| VIH ^① | | - | 12.5 | - | - | 12.5 | - | - | V |
| REFERENCE | @ 15mA Load | 1 | 5.82 | 6.25 | 6.57 | 5.82 | 6.25 | 6.57 | V |
| ANALOG SECTION | | | | | | | | | |
| Current Command Input Range ^① | | - | -13.5 | - | +13.5 | -13.5 | - | +13.5 | V |
| Current Command Input Current ^① | | - | - | - | 1.5 | - | - | 1.5 | mA |
| Transconductance ^⑥ | | 4 | 0.90 | 1.0 | 1.1 | 0.85 | 1.0 | 1.15 | A/V |
| | | 5,6 | 0.85 | 1.0 | 1.15 | - | - | - | A/V |
| Offset Current | Current Command= 0 Volts | 1 | -25 | 0 | +25 | -50 | 0 | +50 | mA |
| Current Monitor ^⑥ | | 4 | 0.90 | 1.0 | 1.1 | 0.85 | 1.0 | 1.15 | V/A |
| | | 5,6 | 0.85 | 1.0 | 1.15 | - | - | - | V/A |
| Current Motor Voltage Swing | | - | -12 | - | +12 | -12 | - | +12 | V |
| Error Amp | @ 5mA Load | | | | | | | | |
| E/A OUT Voltage Swing ^① | | - | -12 | - | +12 | -12 | - | +12 | V |
| Slew Rate ^① | @ 5mA Load | - | 6.8 | 8 | - | 6.8 | 8 | - | V/μsec |
| Gain Bandwidth Product ^① | | - | - | 6.5 | - | - | 6.5 | - | MHz |
| Large Signal Voltage Swing ^① | | - | 175 | 275 | - | 175 | 275 | - | V/mV |
| | Current Limit Adjust | Pin 22 1.92KΩ to GND | 1 | 4 | 5 | 6 | 4 | 5 | 6 |
| OUTPUT SECTION | | | | | | | | | |
| Voltage Drop Across Bridge (1 Upper & 1 Lower) ^① | 5 Amps @ 125° C Tc | - | - | - | 4.5 | - | - | 5 | V |
| | | - | - | - | 7.5 | - | - | - | V |
| Leakage Current ^① | | - | - | - | 5 | - | - | 5 | mA |
| t _{rr} ^① | All Switches off, 270V,150° C | - | - | 35 | - | - | 35 | - | nsec |
| Dead Time ^① | | - | - | 3 | - | - | 3 | - | μsec |

NOTES:

- ① Guaranteed by design but not tested. Typical parameters are representative of actual device performance but are for reference only.
- ② Industrial grade and "E" suffix devices shall be tested to subgroups 1 and 4 unless otherwise specified.
- ③ Military grade devices ("H" suffix) shall be 100% tested to subgroups 1,2,3 and 4.
- ④ Subgroups 5 and 6 testing available upon request.
- ⑤ Subgroup 1,4 TA= TC= +25° C
2,5 TA= TC= +125° C
3,6 TA= TC= -55° C
- ⑥ Measurements do not include offset current at 0V current command.
- ⑦ Continuous operation at or above absolute maximum ratings may adversely effect the device performance and/or life cycle.
- ⑧ When applying power to the device, apply the low voltage followed by the high voltage or alternatively, apply both at the same time. Do not apply high voltage without low voltage present.

APPLICATION NOTES

MSK 4370 PIN DESCRIPTIONS

AV+, BV+, CV+ - are the power connections from the hybrid to the bus. The pins for each phase are brought out separately and must be connected together to the V+ source externally. The external wiring to these pins should be sized according to the RMS current required by the motor. These pins should be bypassed by a high quality monolithic ceramic capacitor for high frequencies and enough bulk capacitance for keeping the V+ supply from drooping.

AØ, BØ & CØ- are the connections to the motor phase windings from the bridge output. The wiring to these pins should be sized according to the current required by the motor. There are no short circuit provisions for these outputs. Shorts to V+ or ground from these pins must be avoided or the bridge will be destroyed.

AVS, BVS, CVS - are the return pins on the bottom of each half bridge. They are brought out separately and should be connected together externally to allow the current from each half bridge to flow through the sense resistor. The wiring on these pins should be sized according to the current requirements of the motor.

RTN - is the power return connection from the module to the bus. All ground returns connect to this point from internal to the module in a star fashion. All external ground connections to this point should also be made in a similar fashion. The V+ capacitors should be returned to this pin as close as possible. Wire sizing to this pin connection should be made according to the required current.

LGND - is an isolated ground connection to the RTN pin of the hybrid that is connected internally. For any circuitry that needs to be connected to the RTN pin without the influence of current flow through RTN should be connected at this point.

GND - is a ground pin that connects to the ground plane for all low powered circuitry inside the hybrid.

+15 VIN - is the input for applying +15 volts to run the low power section of the hybrid. This pin should be bypassed with a 10 µF capacitor and a 0.1 µF capacitor as close to this pin as possible.

-15 VIN - is the input for applying -15 volts to run the low power section of the hybrid. This pin should be bypassed with a 10 µF capacitor and a 0.1 µF capacitor as close to this pin as possible.

CURRENT COMMAND (+, -) - are differential inputs for controlling the module in current mode. Scaled at ±1 amp per volt of input command, the bipolar input allows both forward and reverse current control capability regardless of motor commutation direction. The maximum operational command voltage should be ±10 volts for ±10 amps of motor current.

CURRENT MONITOR- is a pin providing a current viewing signal for external monitoring purposes. This is scaled at ±1 amp of motor current per volt output, up to a maximum of ±10 volts, or ±10 amps. As ±10 amps is exceeded, the peaks of the waveform may become clipped as the rails of the amplifiers are reached. This voltage is typically ±12.5 volts, equating to ±12.5 amps of current peaks.

E/A OUT - is the current loop error amp output connection. It is brought out for allowing various loop compensation circuits to be connected between this and E/A-.

E/A- - is the current loop error amp inverting input connection. It is brought out for allowing various loop compensation circuits to be connected between this and E/A OUT.

CLOCK SYNC- is an input for synchronizing to an external clock. The sync circuit will trigger on the edges of the applied clock and effectively shorten the period of the internal oscillator on each cycle. The frequency can be increased from a free running 14 KHz to 20 KHz maximum. The clock applied shall be 15 volts amplitude with at least a 10% duty cycle.

REFOUT - is a 6.25 volt regulated output to be used for powering the hall devices in various motors. Up to 15 mA of output current is available.

HALL A, B & C - are the hall input pins from the hall devices in the motor. These pins are internally pulled up to 6.25 volts. The halls can reflect a 120/240 degree commutation scheme or a 60/300 degree scheme.

BRAKE - is a pin for commanding the output bridge into a motor BRAKE mode. When pulled low, normal operation commences. When pulled high, the 3 high side bridge switches turn off and the 3 low side bridge switches turn on, causing rapid deceleration of the motor and will cease motor operation until pulled high again. Logic levels for this input are TTL compatible. It is necessary to toggle ON and OFF BRAKE after power up before normal operation can begin. This is necessary because of the bootstrap high-side power supplies for each phase. These are not continuous high-side supplies and need to be refreshed by turning on the low side switches momentarily with the BRAKE. It is internally pulled high.

DIS - is a pin for externally disabling the output bridge. A 15V CMOS logic low will disable the bridge and a 15V CMOS logic high will enable it. After using the DIS pin, the BRAKE must be cycled ON and OFF before normal operation will begin. This is due to the bootstrap high-side supplies needing refreshing.

60/120- is a pin for selecting the orientation of the commutation scheme of the motor. A high state will produce 60/300 degree commutation, whereas a low state will produce 120/240 degree commutation. Logic levels for this input are TTL compatible. It is internally pulled high.

ILIMIT ADJUST - is a pin for externally adjusting the current limit point. By placing a resistor to ground from this pin, a voltage divider is created and the current limit will be lowered. Without an external resistor, the current limit is set at 13 Amps.

APPLICATION NOTES CONTINUED

COMMUTATION TRUTH TABLE

| HALL SENSOR PHASING | | | | | | ICOMMAND = POS. | | | ICOMMAND = NEG. | | | BRAKE |
|---------------------|--------|--------|--------|--------|--------|-----------------|----|----|-----------------|----|----|-------|
| 120° | | | 60° | | | AØ | BØ | CØ | AØ | BØ | CØ | |
| HALL A | HALL B | HALL C | HALL A | HALL B | HALL C | | | | | | | |
| 1 | 0 | 0 | 1 | 0 | 0 | H | - | L | L | - | H | 0 |
| 1 | 1 | 0 | 1 | 1 | 0 | - | H | L | - | L | H | 0 |
| 0 | 1 | 0 | 1 | 1 | 1 | L | H | - | H | L | - | 0 |
| 0 | 1 | 1 | 0 | 1 | 1 | L | - | H | H | - | L | 0 |
| 0 | 0 | 1 | 0 | 0 | 1 | - | L | H | - | H | L | 0 |
| 1 | 0 | 1 | 0 | 0 | 0 | H | L | - | L | H | - | 0 |
| 1 | 1 | 1 | 1 | 0 | 1 | - | - | - | - | - | - | 0 |
| 0 | 0 | 0 | 0 | 1 | 0 | - | - | - | - | - | - | 0 |
| X | X | X | X | X | X | L | L | L | L | L | L | 1 |

1 = High Level
 0 = Low Level
 X = Don't Care

H = SOURCE
 L = SINK
 - = OPEN

NOTE: Because of the true 4 quadrant method of output switching, the output switches will PWM between the ICOMMAND POSITIVE and ICOMMAND NEGATIVE states, with the average percentage based on ICOMMAND being a positive voltage and a negative voltage. With a zero voltage ICOMMAND, the output switches will modulate with exactly a 50% duty cycle between the ICOMMAND POSITIVE and ICOMMAND NEGATIVE states.

EXTERNAL CURRENT LIMIT RESISTOR SELECTION CHART

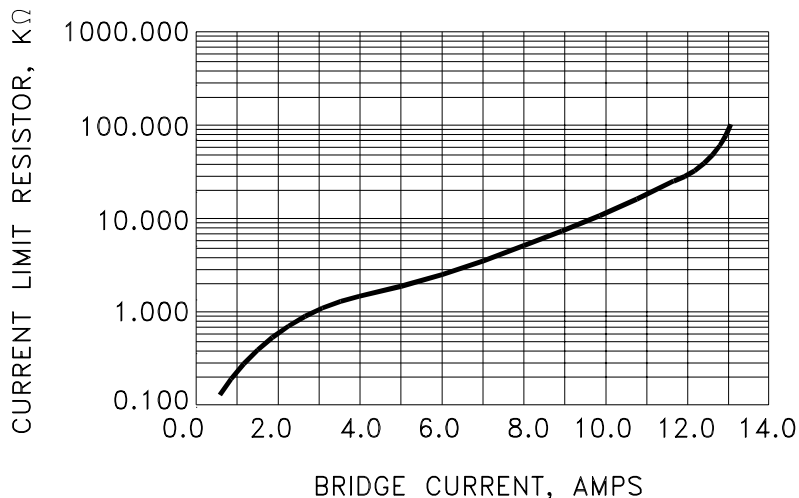

| CURRENT (A) | RESISTOR (KΩ) |
|-------------|---------------|
| 2.0 | 0.56 |
| 4.0 | 1.37 |
| 6.0 | 2.61 |
| 8.0 | 4.77 |
| 10.0 | 9.48 |

BUS VOLTAGE FILTER CAPACITORS

The size and placement of the capacitors for the DC bus has a direct bearing on the amount of noise filtered and also on the size and duration of the voltage spikes seen by the bridge. What is being created is a series RLC tuned circuit with a resonant frequency that is seen as a damped ringing every time one of the transistors switches. For the resistance, wire resistance, power supply impedance and capacitor ESR all add up for the equivalent lumped resistance in the circuit. The inductance can be figured at about 30 nH per inch from the power supply. Any voltage spikes are on top of the bus voltage and the back EMF from the motor. All this must be taken into account when designing and laying out the system. If everything has been minimized, there is another solution. A second capacitance between 5 and 10 times the first capacitor and it should either have some ESR or a resistor can be added in series with the second capacitor to help damp the voltage spikes.

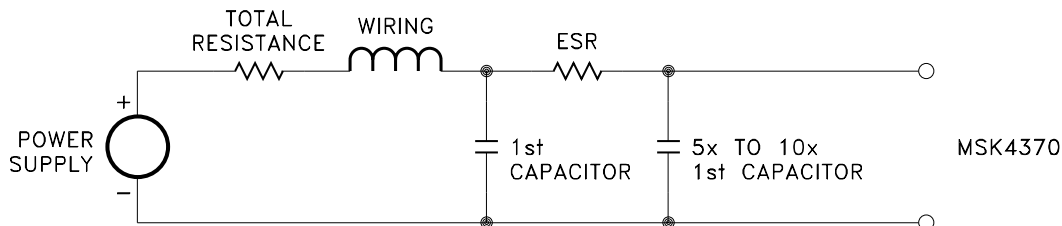

Be careful of the ripple current in all the capacitors. Excessive ripple current, beyond what the capacitors can handle, will destroy the capacitors.

REGULATED VOLTAGE FILTER CAPACITORS

It is recommended that about 10 μF of capacitance (tantalum) for bypassing the + and -15V regulated outputs be placed as close to the module pins as practical. Adding ceramic bypass capacitors of about 0.1 μF or 1 μF will aid in suppressing noise transients.

GENERAL LAYOUT

Good PC layout techniques are a must. Ground planes for the analog circuitry must be used and should be tied back to the small pin grounds 9, 14 and 23. Additional ground, pin 26 is an isolated ground that connects internally directly back to the main DC bus ground pin 27, 28. This can be used as necessary for voltage sensing, etc.

LOW POWER STARTUP

When starting up a system utilizing the MSK 4370 for the first time, there are a few things to keep in mind. First, because of the small size of the module, short circuiting the output phases either to ground or the DC bus will destroy the bridge. The current limiting and control only works for current actually flowing through the bridge. The current sense resistor has to see the current in order for the electronics to control it. If possible, for startup use a lower voltage and lower current power supply to test out connections and the low current stability. With a limited current supply, even if the controller locks up, the dissipation will be limited.

COMPENSATION AND ANTI-WINDUP

By observing the E/A OUT pin which is the error amp output, much can be found out about the health and stability of the system. An even waveform with some rounded triangle wave should be observed. As current goes up, the DC component of the waveform should move up or down. At full current (with a regular supply) the waveform should not exceed + 8 volts positive peak, or -8 volts negative peak. Some audible noise will be heard which will be the commutation frequency. If the motor squeals, there is instability and power should be removed immediately unless power dissipation isn't excessive due to limited supply current. For compensation calculations, refer to the block diagram for all information to determine the amplifier gain for loop gain calculations.

Because this high voltage torque amplifier contains only high-side bootstrap supplies, it must continuously PWM the bridge to refresh the high-side supply capacitors. Additionally, this type of amplifier controls the loop through PWM, so it must PWM all of the time in order to maintain control.

When the bridge commutates the motor through each phasing state, the current path switches windings. The current must be ramped back up after each transition. With an integrating compensation scheme, it is very possible for the error amplifier to exceed the PWM maximum and minimum voltages. When this happens, the loop stops PWM control and the error amplifier will continue to integrate and ramp up to the voltage rail. This is called integrator windup.

Recovery from integrator windup can take a significant amount of time, long enough for the bootstrap supply capacitors to be depleted and shut off the gate the gate drive. This must be prevented from happening. By placing zener diode clamps across the error amplifier output to the inverting input, it will clamp the amplifier from running past the PWM maximum and minimum.

For a free-running clock with no synchronization, the zeners used should be 7.5V. In each direction, the voltage will be 7.5V plus one diode drop, or 8.2V to 8.5V. If the synchronization pin is being used for clock sync, then that voltage may have to be lower, as the sync scheme effectively shortens up the PWM ramp to increase frequency and sync the clock. A 100 ohm series current limiting resistor is necessary to prevent the error amplifier from driving too much current back through the feedback when the diodes are conducting

MSK4370 TEST CIRCUIT

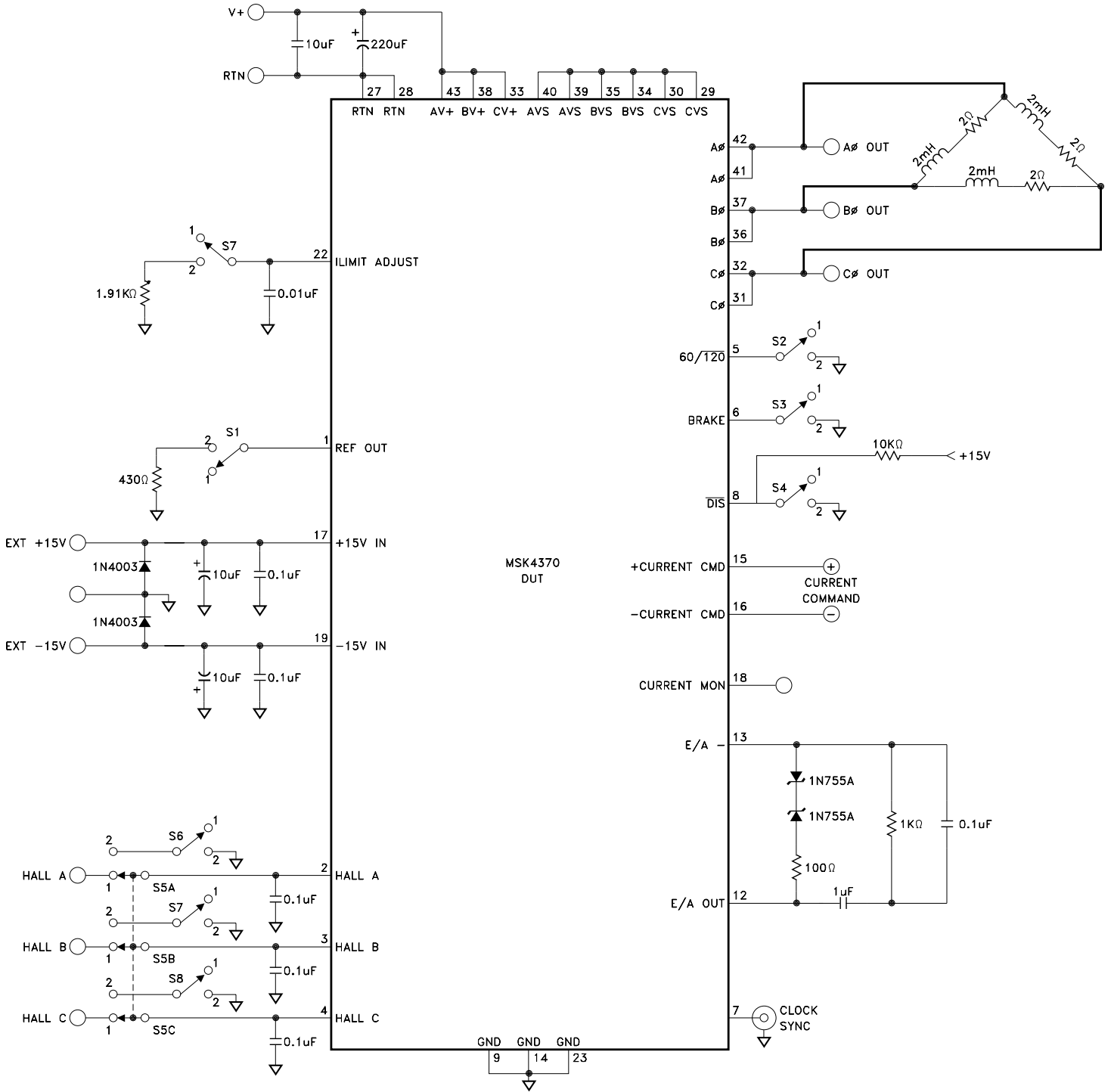

TYPICAL TEST SCHEMATIC

