



M.S.KENNEDY CORP.

30 AMP, 75V, 3 PHASE MOSFET DC BRUSHLESS DIGITAL MOTOR CONTROLLER

4365

4707 Dey Road Liverpool, N.Y. 13088

(315) 701-6751

FEATURES:

- 75 Volt Motor Supply Voltage
- 30 Amp Output Switch Capability
- 100% Duty Cycle High Side Conduction Capable
- Shoot-Through/Cross Conduction Protection
- Hall Sensing and Digital Commutation Circuitry on Board
- Locked Anti-Phase Full Complementary Digital PWM
- Full Four Quadrant Torque Control Capability
- 60°/ 120° Phasing Selectable
- Good Accuracy Around Zero Torque
- Isolated Package Design for High Voltage Isolation Plus Good Thermal Transfer

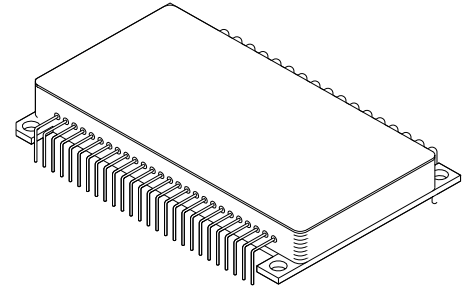

DESCRIPTION:

The MSK 4365 is a non-isolated, complete digitally controlled, 3 Phase MOSFET Bridge DC Brushless Motor Control System in a convenient isolated hermetic package. The controller is capable of 30 amps of output current with 75 volt rated MOSFET transistors. Bridge protection is included. The digital signal processor controls the hall sensing, commutation, current sensing and PWM control for a complete closed loop, current mode torque controller. The PWM scheme used by the processor is "Locked Anti-Phase Full Complementary" digital PWM. This provides full four quadrant control of the motor around zero torque without losing loop control. Various compensation schemes can be accommodated. The MSK4365 has good thermal conductivity for MOSFET power dissipation due to the isolated package design that allows direct heat sinking of the device without insulators. Possible I/O schemes are proposed below. I/O includes digital command control, digital current monitor and digital feedback compensation values. Possible analog control includes current command, analog current monitor output and analog feedback compensation.

BLOCK DIAGRAM

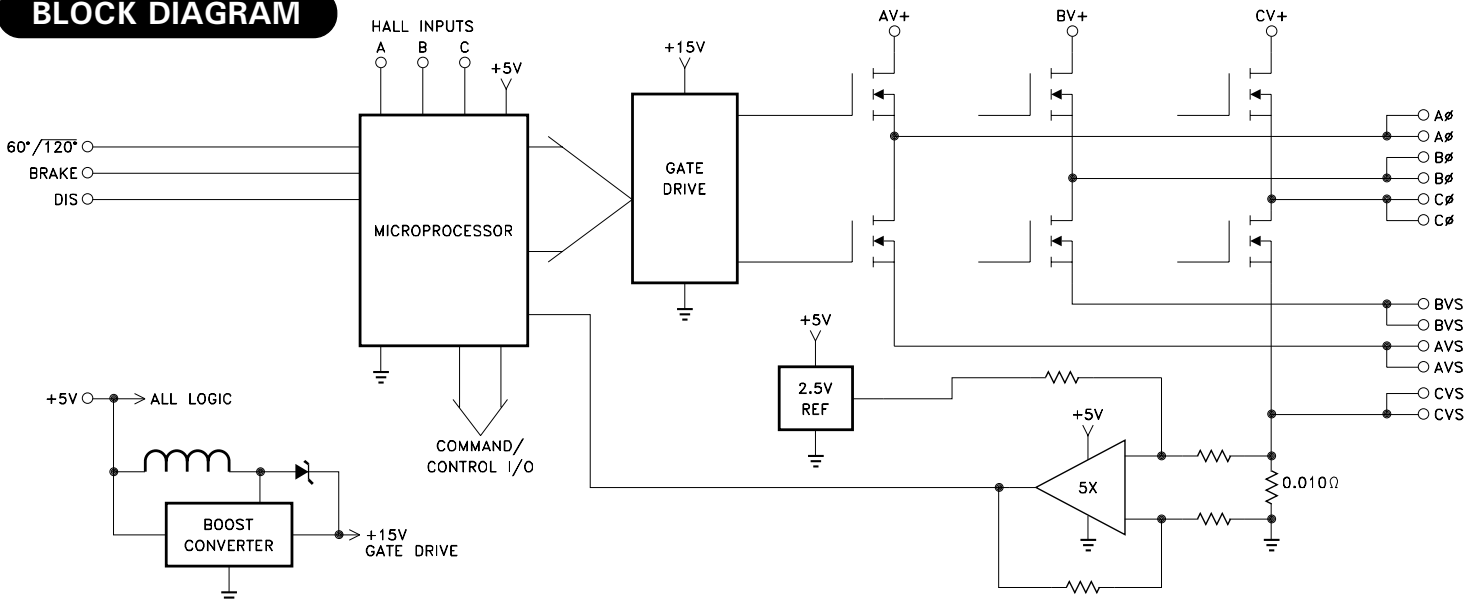

POSSIBLE I/O SCHEMES

- SPI (Serial Peripheral Interface)
- I²C (Inter-Integrated Circuit)
- CAN (Controller Area Network)
- USB (Universal Serial Bus)
- Analog (Command, Monitor, Compensation)

PIN-OUT INFORMATION

TBD