



M.S.KENNEDY CORP.

**25 AMP, 500 VOLT IGBT PLUS DIODE
FULLY ISOLATED
SMART POWER 3-PHASE MOTOR
DRIVE POWER HYBRID**

4358

4707 Dey Road Liverpool, N.Y. 13088

(315) 701-6751

FEATURES:

- 500V, 25 Amp Capability at 110° C
- Fully Isolated Bridge
- Ultra Low Thermal Resistance
- Integral Free Wheeling Fast Recovery Epitaxial Diode (FRED)
- Self-Contained, Smart Lowside/Highside Drive Circuitry and Isolated Supply
- Adjustable Deadtime
- Capable of Switching Frequencies to 20KHz
- Isolated Case Allows Direct Heat Sinking
- Bolt-down Design Allows Superior Heat Dissipation
- Contact MSK for MIL-PRF-38534 Qualification Status

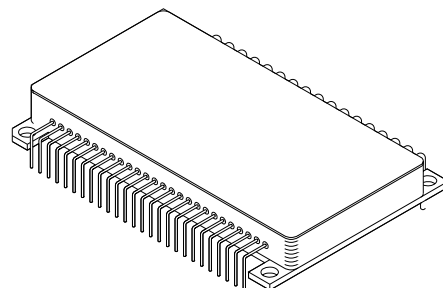

DESCRIPTION:

The MSK 4358 is a 25 Amp, 3 Phase Isolated Bridge Smart Power Motor Drive Hybrid with a 500 volt rating. The output switches are Insulated Gate Bipolar Transistors (IGBT's) tailored for high switching speeds. The free-wheeling diodes are Fast Recovery Epitaxial Diodes (FRED's) to provide matched current capabilities with the IGBT's and are specified with excellent reverse recovery times at high current ratings. The bridge is optically isolated from the control circuitry. This new smart power motor drive hybrid is compatible with 5v CMOS logic levels. The internal circuitry prevents simultaneous turn-on of the in-line half bridge transistors with adjustable deadtime to prevent shoot-through. Undervoltage lockout shuts down the bridge when the supply voltage gets to a point of incomplete turn-on of the output switches. The isolated internal high-side power supply derived from the + 15 volt supply completely eliminates the need for 3 floating independent power supplies for the high-side drive.

EQUIVALENT SCHEMATIC

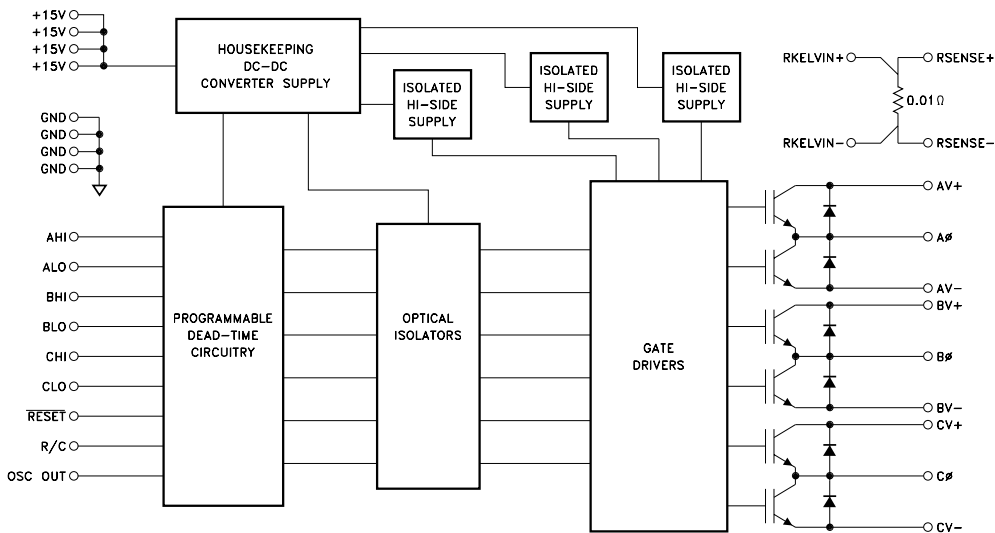

TYPICAL APPLICATIONS

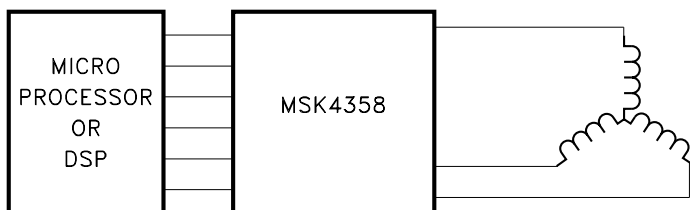

3 PHASE SIX STEP DC BRUSHLESS MOTOR DRIVE
OR 3 PHASE SINUSOIDAL INDUCTION MOTOR DRIVE

PIN-OUT INFORMATION

1	+ 15V	12	GND	23	N/C	34	N/C
2	GND	13	RESET	24	N/C	35	BV-
3	AHI	14	R/C	25	RKELVIN+	36	N/C
4	ALO	15	+ 15V	26	RKELVIN-	37	BØ
5	BHI	16	GND	27	RSENSE-	38	BV+
6	BLO	17	OSCOU	28	RSENSE+	39	N/C
7	+ 15V	18	N/C	29	CV-	40	AV-
8	GND	19	N/C	30	N/C	41	N/C
9	CHI	20	N/C	31	CØ	42	AØ
10	CLO	21	N/C	32	CV+	43	AV+
11	+ 15V	22	N/C	33	N/C		

ABSOLUTE MAXIMUM RATING

⑥

V+	High Voltage Supply ⑦	500V
+15V	Logic Supply	18V
I _{OUT}	Continuous Output Current	25A
I _{PK}	Peak Output Current (1 pulse, 10μSec)	60A
θ _{JC}	Thermal Resistance (IGBT - Junction to Case)	0.84°C/W
	Thermal Resistance (Diode - Junction to Case)	0.90°C/W

T _{ST}	Storage Temperature Range	-65°C to +150°C
T _{LD}	Lead Temperature Range(10 Seconds)	300°C
T _C	Case Operating Temperature	MSK4358 -40°C to +85°C
		MSK4358H/E -55°C to +125°C
T _J	Junction Temperature	+150°C

ELECTRICAL SPECIFICATIONS

All Ratings: T_c = +25°C Unless Otherwise Specified

Parameters	Test Conditions	Group A Subgroup ⑤	MSK 4358H/E ③			MSK 4358 ②			UNITS
			Min.	Typ.	Max.	Min.	Typ.	Max.	
OUTPUT CHARACTERISTICS									
VC-E On Voltage (Each IGBT)	I _C = 25A	1	-	-	2.5	-	-	2.35	V
		2	-	-	2.35	-	-	-	V
		3	-	-	2.3	-	-	-	V
Instantaneous Forward Voltage (FRED Flyback Diode)	I _D = 25A	1	-	-	1.75	-	-	1.75	V
		2	-	-	1.7	-	-	-	V
		3	-	-	2.0	-	-	-	V
Turn On Switching Energy ①	V ₊ = 270V, 25Amps @125°C L = 100μH, R = 0.2Ω	-	-	-	2.0	-	-	2.2	mJ
Turn Off Switching Energy ①		-	-	-	1.1	-	-	1.2	mJ
Reverse Recovery Time ①	I _D = 25A, di/dt = 400A/μS, V _r = 350V	-	-	-	180	-	-	180	nS
Leakage Current (Each IGBT/Diode)	V ₊ = 500V	1	-	-	150	-	25	150	μA
	V ₊ = 400V	2	-	-	1.5	-	-	-	mA
	V ₊ = 500V	3	-	-	150	-	-	-	μA
BIAS SUPPLY CHARACTERISTICS									
Quiescent Bias Current	V _{CC} = 15V	1	-	230	300	-	230	330	mA
		2	-	170	250	-	-	-	mA
		3	-	230	300	-	-	-	mA
Supply Voltage ①		-	14.75	15.00	15.25	14.75	15.00	15.25	V
INPUT SIGNALS CHARACTERISTICS ①									
Positive Trigger Threshold Voltage		1,2,3	3.65	-	-	3.65	-	-	V
Negative Trigger Threshold Voltage		1,2,3	-	-	0.8	-	-	0.8	V
SWITCHING CHARACTERISTICS ①									
Upper Drive: Deadtime R/C = 10K/47pF	V ₊ = 270V, I _C = 25A								
Turn-On Propagation Delay		4	-	6.0	6.2	-	6.0	6.3	μS
Turn-Off Propagation Delay		4	-	1.1	1.2	-	1.1	1.3	μS
Turn-On		4	-	50	60	-	50	60	nS
Turn-Off		4	-	80	90	-	80	90	nS
Lower Drive: Deadtime R/C = 10K/47pF ①	V ₊ = 270V, I _C = 25A								
Turn-On Propagation Delay		4	-	2.3	2.7	-	2.3	2.8	μS
Turn-Off Propagation Delay		4	-	3.1	3.4	-	3.1	3.5	μS
Turn-On		4	-	50	70	-	50	70	nS
Turn-Off		4	-	66	75	-	66	75	nS
SENSE RESISTOR									
Resistance	@2 Amps	1	9.7	10	10.3	9.67	10	10.33	mΩ
		2	9.5	10.17	10.5	-	-	-	mΩ
		3	9.73	10.03	10	-	-	-	mΩ

NOTES:

- ① Guaranteed by design but not tested. Typical parameters are representative of actual device performance but are for reference only.
- ② Industrial grade and "E" suffix devices shall be tested to subgroups 1 and 4 unless otherwise specified.
- ③ Military grade devices ("H" suffix) shall be 100% tested to subgroups 1,2,3 and 4.
- ④ Subgroups 5 and 6 testing available upon request.
- ⑤ Subgroup 1,4 T_A = T_C = +25°C
2,5 T_A = T_C = +125°C
3,6 T_A = T_C = -55°C
- ⑥ Continuous operation at or above absolute maximum ratings may adversely effect the device performance and/or life cycle.
- ⑦ When applying power to the device, apply the low voltage followed by the high voltage or alternatively, apply both at the same time. Do not apply high voltage without low voltage present.

APPLICATION NOTES

MSK4358 PIN DESCRIPTION

+15V - is the low voltage supply for all the internal logic and isolated supplies which provide power to the gate drivers. A 0.1µF ceramic capacitor in parallel with a 22µF tantalum capacitor is recommended for bypassing the low voltage supply to GND.

Note: This is a power sequense sensitive part. Either turn on all supplies simultaneously or provide +15V first, then V+ voltages.

GND - is the low voltage supply return for the +15V. All bypassing of the +15V should return here. Since the output section of the hybrid is completely isolated, there are no restrictions for potential differences between this GND and any hi-voltage returns, up to 500V.

AHI,BHI,CHI - are the logic inputs for controlling the switching of the corresponding hi-side bridge outputs. A logic high will turn on the corresponding hi-side output. The input levels are 5V CMOS compatible. If one of these inputs are active at the same time as the corresponding low-side bridge outputs, neither output will be allowed to turn on until one of the inputs is switched low. There will be a deadtime inserted before the corresponding bridge output is switched in all cases. This prevents simultaneous conduction of the output, shorting high voltage supply and destroying the bridge.

ALO,BLO,CLO - are the logic inputs for controlling the switching of the corresponding low-side bridge outputs. A logic high will turn on the corresponding low-side output. The input levels are 5V CMOS compatible. If one of these inputs are active at the same time as the corresponding hi-side bridge outputs, neither output will be allowed to turn on until one of the inputs is switched low. There will be a deadtime inserted before the corresponding bridge output is switched in all cases. This prevents simultaneous conduction of the output, shorting the high voltage supply and destroying the bridge.

RESET - is an active low logic input for causing all switching to cease. The input level is 5V CMOS compatible. Upon releasing RESET, the outputs will resume after the dead time.

R/C - is the input pin for setting the deadtime of the bridge. Connecting a resistor between this input and OSC OUT, and a capacitor to ground will create the time for an internal oscillator.

OSC OUT - is a pin that brings the deadtime oscillator out to be connected through the timing resistor to R/C. This is not an output to be used externally, but just for the timing circuit.

AV+ ,BV+ ,CV+ - are pins for connecting the tops of each half bridge to the high voltage supply. Each pin must be connected individually, as there is no internal connection across the three half bridges. Proper power supply bypassing must be connected to these pins and the V- pins as close to the hybrid as possible for proper filtering.

Note: This is a power sequense sensitive part. Either turn on all supplies simultaneously or provide +15V first, then V+ voltages.

AV-,BV-,CV- - are pins for connecting the bottoms of each half bridge to the high voltage supply return. Each pin must be connected individually, as there is no internal connection across the three half bridges. Proper power supply bypassing must be connected to these pins and the V+ pins as close to the hybrid as possible for proper filtering.

AØ, BØ, CØ - are the pins connecting the 3 phase bridge switch outputs.

RSENSE+ - is the pin for connecting to the internal sense resistor. It has a value of 0.010 ohms, 20 watts. AV-,BV- and CV- should connect to this point for sensing the current at the bottom of the bridge.

RSENSE- - is the pin for connecting the internal sense resistor to the high voltage return.

RKELVIN+ - is the pin for connecting to the sense resistor +KELVIN connection. This is on the same side of the resistor as RSENSE+ .

RKELVIN- - is the pin for connecting to the sense resistor -KELVIN connection. This is on the same side of the resistor as RSENSE-.

DEADTIME SELECTION

The amount of deadtime required is based on the propagation delay of the input to actual completion of switching of the output transistors. Not taking all this into account can possibly allow the opposite transistor in a half bridge to turn on before the active transistor can turn off. Excessive current will flow through the half bridge because this creates a momentary short across the power supply.

Once all these factors are taken into account, the deadtime can be determined. Allow sufficient safety factor for changes in components over temperature, and variations from system to system in production.

Deadtime is exactly 8 R/C clock periods. Use the formula:

Max. Clock = 8/Min. Deadtime

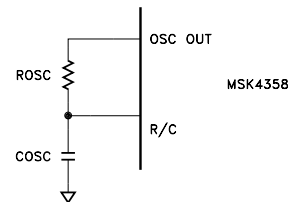

For clock operation below 1MHz:

$$\text{Clock Frequency} = \frac{0.95}{\text{Cosc} \times \text{RosC}}$$

For clock operation above 1MHz:

$$\text{Clock Frequency} = \frac{0.95}{\text{Cosc} (\text{RosC} + 30) + 3 \times 10^8}$$

As an alternative, the R/C pin can be driven directly with an HCMOS compatible clock up to 24MHz.

OSCILLATOR FREQUENCY COMPONENT SELECTION FOR MSK4358

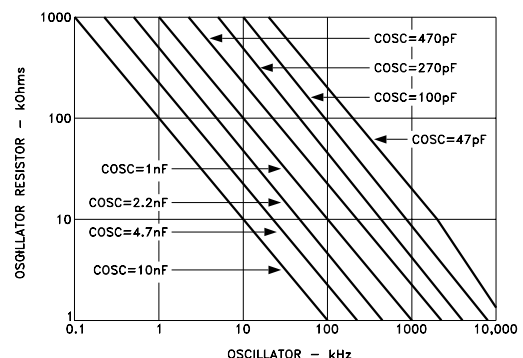

TYPICAL PERFORMANCE CURVES

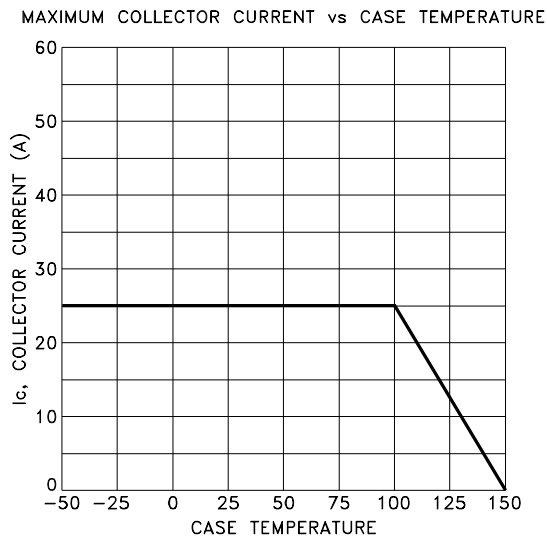
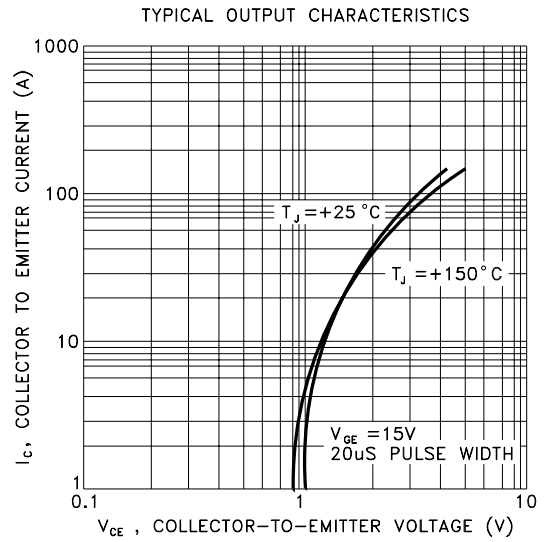
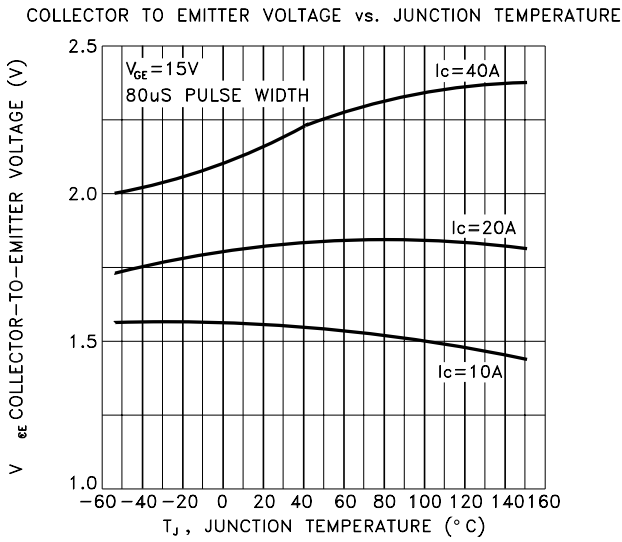
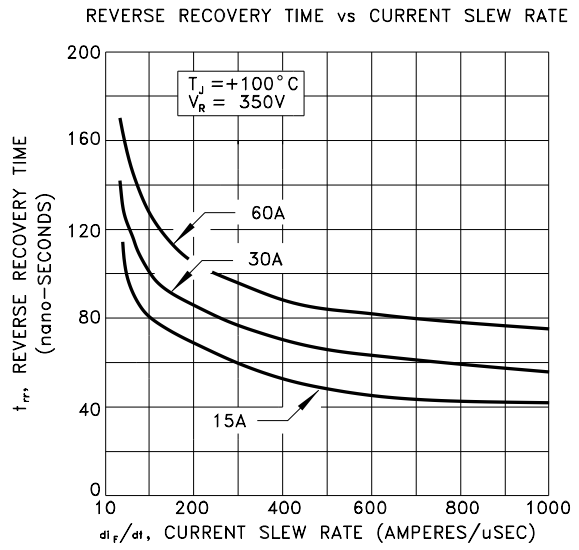
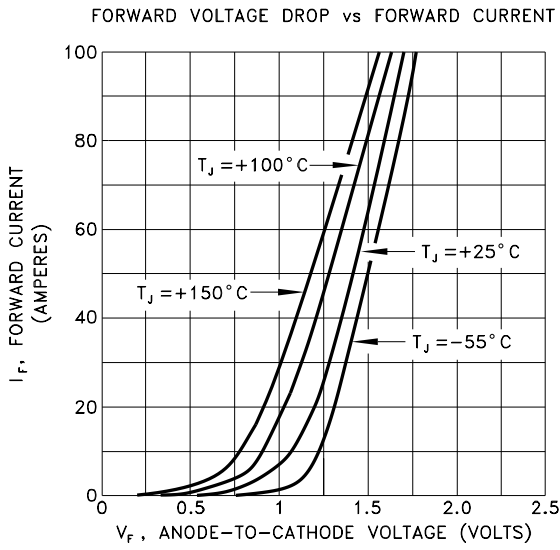

TYPICAL SYSTEM OPERATION

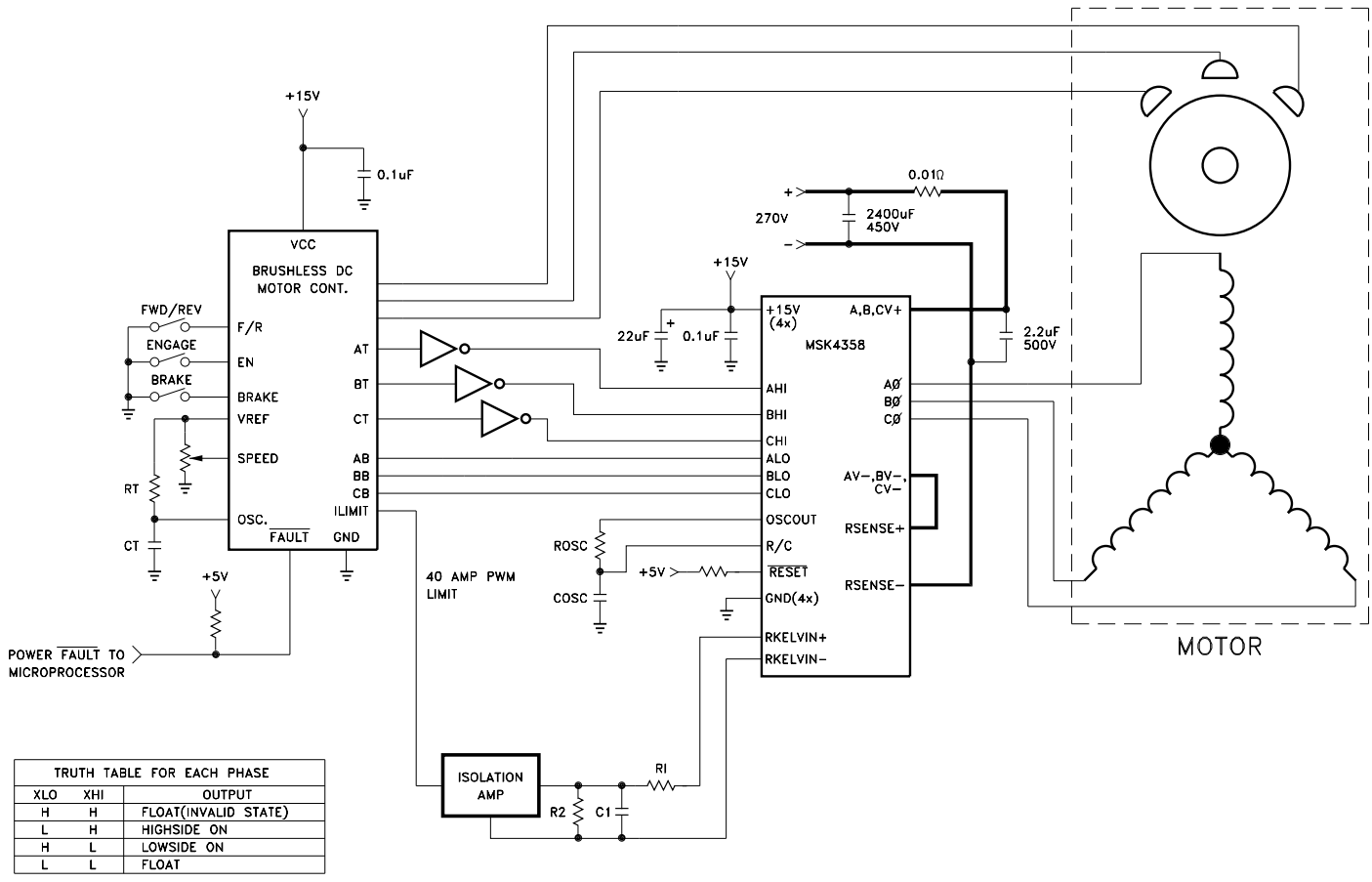

The MSK4358 is designed to be used with a + 270 volt high voltage bus, + 15 volt low power bus, and + 5 volt logic signals. Proper derating should be applied when designing the MSK4358 into a system. High frequency layout techniques with ground planes on a printed circuit board is the only method that should be used for circuit construction. This will prevent pulse jitter caused by excessive noise pickup on the current sense signal or the error amp signal.

Ground planes for the low power circuitry and high power circuitry should be kept separate. The two sections of the hybrid are completely isolated, and can float relative to each other without referencing one to the other. An RC filter will filter out the current spikes and keep the detected noise for that circuit down to a minimum.

The logic signals coming from the typical motor controller IC are set up for driving N channel low side and P channel high side switches directly, and are usually 15 volt levels. Provision should be made for getting 5 volt logic signals to the MSK4358 of the correct assertion levels. Typically, the low side signals out of the controller are high active and the high side are low active. Inverters are shown in the system schematic for the high side controller output.

MECHANICAL SPECIFICATIONS

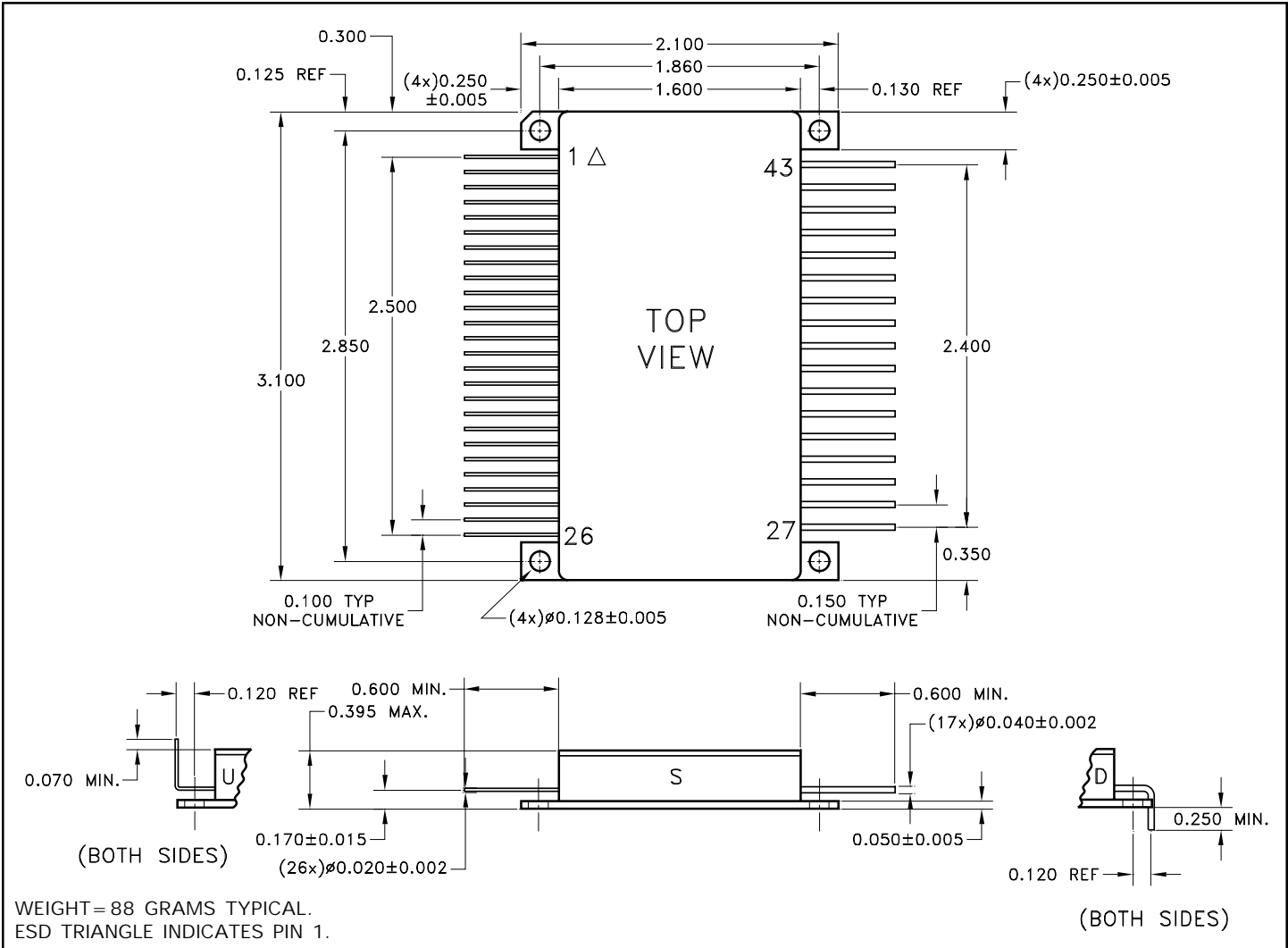

WEIGHT = 88 GRAMS TYPICAL.
ESD TRIANGLE INDICATES PIN 1.

ALL DIMENSIONS ARE ± 0.010 INCHES UNLESS OTHERWISE LABELED

ORDERING INFORMATION

MSK4358 H U

LEAD CONFIGURATION

S = STRAIGHT, U = BENT UP, D = BENT DOWN

SCREENING

BLANK = INDUSTRIAL; E = EXTENDED RELIABILITY;

H = CLASS H

GENERAL PART NUMBER

THE ABOVE EXAMPLE IS A MILITARY GRADE HYBRID WITH LEADS BENT UP.

M.S. Kennedy Corp.
4707 Dey Road Liverpool, New York 13088
Phone (315) 701-6751
FAX (315) 701-6752
www.mskennedy.com

The information contained herein is believed to be accurate at the time of printing. MSK reserves the right to make changes to its products or specifications without notice, however, and assumes no liability for the use of its products. Please visit our website for the most recent revision of this datasheet.

Contact MSK for MIL-PRF-38534 qualification status.