



M.S.KENNEDY CORP.

**50 AMP, 500 VOLT IGBT PLUS DIODE  
FULLY ISOLATED  
SMART POWER 3-PHASE MOTOR  
DRIVE POWER HYBRID**

**4351**

4707 Dey Road Liverpool, N.Y. 13088

(315) 701-6751

**FEATURES:**

- 500V, 50 Amp Capability at 110° C
- Fully Isolated Bridge
- Ultra Low Thermal Resistance
- Integral Free Wheeling Fast Recovery Epitaxial Diode (FRED)
- Self-Contained, Smart Lowside/Highside Drive Circuitry and Isolated Supply
- Adjustable Deadtime
- Capable of Switching Frequencies to 20KHz
- Isolated Case Allows Direct Heat Sinking; On Board Temp Sensor
- Bolt-down Design Allows Superior Heat Dissipation
- Contact MSK for MIL-PRF-38535 Qualification Status

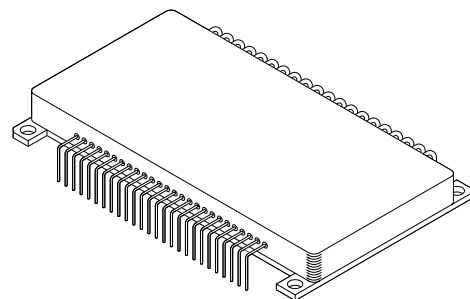

**DESCRIPTION:**

The MSK 4351 is a 50 Amp, 3 Phase Isolated Bridge Smart Power Motor Drive Hybrid with a 500 volt rating. The output switches are Insulated Gate Bipolar Transistors (IGBT's) tailored for high switching speeds. The free-wheeling diodes are Fast Recovery Epitaxial Diodes (FRED's) to provide matched current capabilities with the IGBT's and are specified with excellent reverse recovery times at high current ratings. The bridge is optically isolated from the control circuitry. This new smart power motor drive hybrid is compatible with 5V CMOS logic levels. The internal circuitry prevents simultaneous turn-on of the in-line half bridge transistors with adjustable deadtime to prevent shoot-through. Undervoltage lockout shuts down the bridge when the supply voltage gets to a point of incomplete turn-on of the output switches. The isolated internal high-side power supply derived from the + 15 volt supply completely eliminates the need for 3 floating independent power supplies for the high-side drive.

**EQUIVALENT SCHEMATIC**

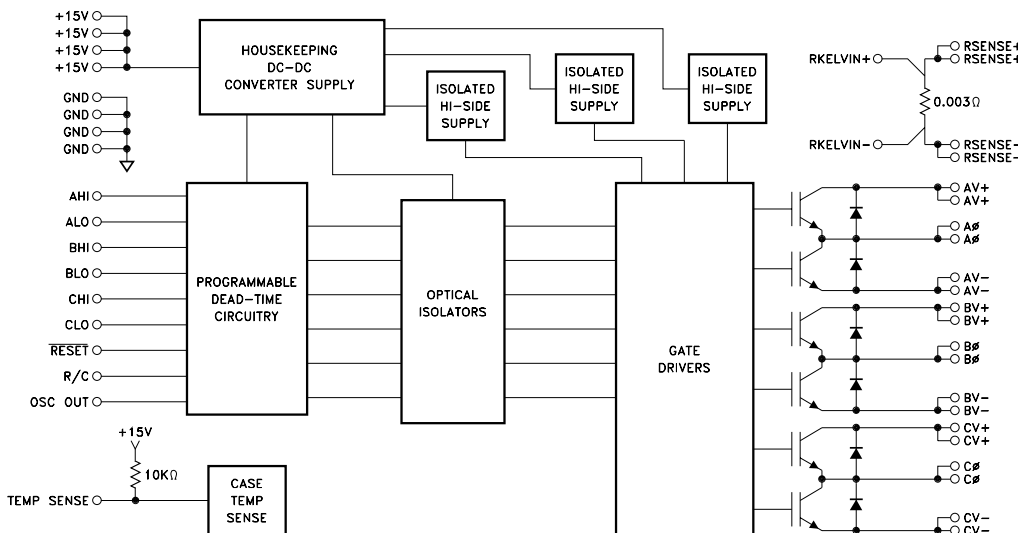

**TYPICAL APPLICATIONS**

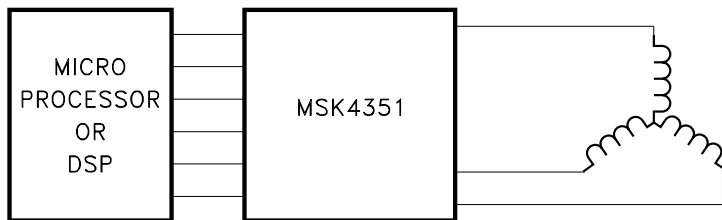

3 PHASE SIX STEP DC BRUSHLESS MOTOR DRIVE  
OR 3 PHASE SINUSOIDAL INDUCTION MOTOR DRIVE

**PIN-OUT INFORMATION**

1 + 15V	13 RESET	25 RKELVIN+	37 BV-
2 GND	14 R/C	26 RKELVIN-	38 BV-
3 AHI	15 + 15V	27 RSENSE-	39 BØ
4 ALO	16 N/C	28 RSENSE-	40 BØ
5 BHI	17 OSCOUT	29 RSENSE+	41 BV+
6 BLO	18 GND	30 RSENSE+	42 BV+
7 + 15V	19 N/C	31 CV-	43 AV-
8 GND	20 N/C	32 CV-	44 AV-
9 CHI	21 N/C	33 CØ	45 AØ
10 CLO	22 N/C	34 CØ	46 AØ
11 + 15V	23 N/C	35 CV+	47 AV+
12 GND	24 TEMP SENSE	36 CV+	48 AV+

## ABSOLUTE MAXIMUM RATING <sup>⑦</sup>

V+	High Voltage Supply <sup>⑧</sup>	500V
+15V	Logic Supply	18V
I <sub>OUT</sub>	Continuous Output Current	50A
I <sub>PK</sub>	Peak Output Current (1 pulse, 10μSec)	100A
θ <sub>JC</sub>	Thermal Resistance (IGBT - Junction to Case)	0.38°C/W
	Thermal Resistance (Diode - Junction to Case)	0.45°C/W

T <sub>ST</sub>	Storage Temperature Range	-65°C to +150°C
T <sub>LD</sub>	Lead Temperature Range(10 Seconds)	300°C
T <sub>C</sub>	Case Operating Temperature	
	MSK4351	-40°C to +85°C
	MSK4351H/E	-55°C to +125°C
T <sub>J</sub>	Junction Temperature	+150°C

## ELECTRICAL SPECIFICATIONS

All Ratings: T<sub>c</sub> = +25°C Unless Otherwise Specified

Parameters	Test Conditions	Group A Subgroup ⑤	MSK 4351H/E ③			MSK 4351 ②			UNITS
			Min.	Typ.	Max.	Min.	Typ.	Max.	
<b>OUTPUT CHARACTERISTICS</b>									
VC-E On Voltage (Each IGBT) ⑥	I <sub>c</sub> = 50A	1	-	1.95	2.5	-	1.95	2.6	V
		2	-	2.0	2.4	-	-	-	V
		3	-	2.3	2.75	-	-	-	V
Instantaneous Forward Voltage ⑥ (FRED Flyback Diode)	I <sub>D</sub> = 50A	1	-	1.4	1.8	-	1.4	1.9	V
		2	-	1.3	1.5	-	-	-	V
		3	-	1.7	2.2	-	-	-	V
Turn On Switching Energy ①	V <sub>t</sub> = 270V, 50Amps @125°C	-	-	-	4.1	-	-	4.5	mJ
Turn Off Switching Energy ①	L = 100μH, R = 0.2Ω	-	-	-	2.3	-	-	2.5	mJ
Reverse Recovery Time ①	I <sub>D</sub> = 50A, di/dt = 400A/uS, V <sub>r</sub> = 350V	-	-	-	180	-	-	180	nS
Leakage Current (Each IGBT/Diode)	V+ = 500V	1	-	25	150	-	25	150	uA
	V+ = 400V	2	-	1.6	2.5	-	-	-	mA
	V+ = 500V	3	-	15	150	-	-	-	uA
<b>BIAS SUPPLY CHARACTERISTICS</b>									
Quiescent Bias Current	V <sub>CC</sub> = 15V	1	-	230	300	-	230	330	mA
		2	-	170	250	-	-	-	mA
		3	-	230	300	-	-	-	mA
Supply Voltage ①		-	14.75	15.00	15.25	14.75	15.00	15.25	V
<b>INPUT SIGNALS CHARACTERISTICS</b>									
Positive Trigger Threshold Voltage		1,2,3	3.65	-	-	3.65	-	-	V
Negative Trigger Threshold Voltage		1,2,3	-	-	0.8	-	-	0.8	V
<b>SWITCHING CHARACTERISTICS ①</b>									
Upper Drive: Deadtime R/C = 10K/47pF	V+ = 270V, I <sub>c</sub> = 50A								
Turn-On Propagation Delay		4	-	6.0	6.2	-	6.0	6.3	μS
Turn-Off Propagation Delay		4	-	1.1	1.2	-	1.1	1.3	μS
Turn-On		4	-	50	60	-	50	60	nS
Turn-Off		4	-	80	90	-	80	90	nS
Lower Drive: Deadtime R/C = 10K/47pF	V+ = 270V, I <sub>c</sub> = 50A								
Turn-On Propagation Delay		4	-	2.3	2.7	-	2.3	2.7	μS
Turn-Off Propagation Delay		4	-	3.1	3.4	-	3.1	3.4	μS
Turn-On		4	-	50	70	-	50	70	nS
Turn-Off		4	-	66	75	-	66	75	nS
<b>TEMPERATURE SENSOR</b>									
Initial Accuracy ①	T <sub>C</sub> = 25°C	1	-	±2.0	±5.0	-	±3.0	±6.0	°C
Overall Accuracy	T <sub>MIN</sub> ≤ T <sub>C</sub> ≤ T <sub>MAX</sub>	2,3	-	±5.0	±8.0	-	-	-	°C
<b>SENSE RESISTOR</b>									
Resistance	@2 Amps	1	2.91	3.0	3.09	2.9	3	3.1	mΩ
		2	2.95	3.05	3.14	-	-	-	mΩ
		3	2.92	3.01	3.10	-	-	-	mΩ

### NOTES:

- ① Guaranteed by design but not tested. Typical parameters are representative of actual device performance but are for reference only.
- ② Industrial grade and "E" suffix devices shall be tested to subgroups 1 and 4 unless otherwise specified.
- ③ Military grade devices ("H" suffix) shall be 100% tested to subgroups 1,2,3 and 4.
- ④ Subgroups 5 and 6 testing available upon request.
- ⑤ Subgroup 1,4 TA = TC = +25°C  
2,5 TA = TC = +125°C  
3,6 TA = TC = -55°C
- ⑥ Measurements are made by forcing current through one pin and measuring on the other for determining thermal dissipation on the IGBT/diode. When measuring on the pins very close to the package, add approximately 0.3V to the limits to account for pin resistance.
- ⑦ Continuous operation at or above absolute maximum ratings may adversely effect the device performance and/or life cycle.
- ⑧ When applying power to the device, apply the low voltage followed by the high voltage or alternatively, apply both at the same time. Do not apply high voltage without low voltage present.

## APPLICATION NOTES

### MSK4351 PIN DESCRIPTION

**+ 15V** - is the low voltage supply for all the internal logic and isolated supplies which provide power to the gate drivers. A 0.1μF ceramic capacitor in parallel with a 22μF tantalum capacitor is recommended for bypassing the low voltage supply to GND.

**GND** - is the low voltage supply return for the + 15V. All bypassing of the + 15V should return here. Since the output section of the hybrid is completely isolated, there are no restrictions for potential differences between this GND and any hi-voltage returns, up to 500V.

**AHI,BHI,CHI** - are the logic inputs for controlling the switching of the corresponding hi-side bridge outputs. A logic high will turn on the corresponding hi-side output. The input levels are 5V CMOS compatible. If one of these inputs are active at the same time as the corresponding low-side bridge outputs, neither output will be allowed to turn on until one of the inputs is switched low. There will be a deadtime inserted before the corresponding bridge output is switched in all cases. This prevents simultaneous conduction of the output, shorting high voltage supply and destroying the bridge.

**ALO,BLO,CLO** - are the logic inputs for controlling the switching of the corresponding low-side bridge outputs. A logic high will turn on the corresponding low-side output. The input levels are 5V CMOS compatible. If one of these inputs are active at the same time as the corresponding hi-side bridge outputs, neither output will be allowed to turn on until one of the inputs is switched low. There will be a deadtime inserted before the corresponding bridge output is switched in all cases. This prevents simultaneous conduction of the output, shorting the high voltage supply and destroying the bridge.

**RESET** - is an active low logic input for causing all switching to cease. The input level is 5V CMOS compatible. Upon releasing **RESET**, the outputs will resume after the dead time.

**R/C** - is the input pin for setting the deadtime of the bridge. Connecting a resistor between this input and OSC OUT, and a capacitor to ground will create the time for an internal oscillator.

**OSC OUT** - is a pin that brings the deadtime oscillator out to be connected through the timing resistor to R/C. This is not an output to be used externally, but just for the timing circuit.

**AV+,BV+,CV+** - are pins for connecting the tops of each half bridge to the high voltage supply. Each pin must be connected individually, as there is no internal connection across the three half bridges. Proper power supply bypassing must be connected to these pins and the V- pins as close to the hybrid as possible for proper filtering.

**AV-,BV-,CV-** - are pins for connecting the bottoms of each half bridge to the high voltage supply return. Each pin must be connected individually, as there is no internal connection across the three half bridges. Proper power supply bypassing must be connected to these pins and the V+ pins as close to the hybrid as possible for proper filtering.

**AØ, BØ, CØ** - are the pins connecting the 3 phase bridge switch outputs.

**TEMP SENSE** - is a pin for measuring the output of a temperature sensor IC. The case temperature is depicted as a voltage corresponding to 10mV/°C with 0 volts equating to absolute zero, 0° K or -273° C. This temperature sensor IC is pulled up to + 15V through a 10KΩ resistor internally. Buffering of the output will be necessary if it needs to be connected to a low impedance load.

**RSENSE+** - is the pin for connecting to the internal sense resistor. It has a value of 0.003 ohms, 20 watts. AV-,BV- and CV- should connect to this point for sensing the current at the bottom of the bridge.

**RSENSE-** - is the pin for connecting the internal sense resistor to the high voltage return.

**RKELVIN+** - is the pin for connecting to the sense resistor + KELVIN connection. This is on the same side of the resistor as RSENSE+.

**RKELVIN-** - is the pin for connecting to the sense resistor -KELVIN connection. This is on the same side of the resistor as RSENSE-.

### DEADTIME SELECTION

The amount of deadtime required is based on the propagation delay of the input to actual completion of switching of the output transistors. Not taking all this into account can possibly allow the opposite transistor in a half bridge to turn on before the active transistor can turn off. Excessive current will flow through the half bridge because this creates a momentary short across the power supply.

Once all these factors are taken into account, the deadtime can be determined. Allow sufficient safety factor for changes in components over temperature, and variations from system to system in production.

Deadtime is exactly 8 R/C clock periods. Use the formula:

Max. Clock = 8/Min. Deadtime

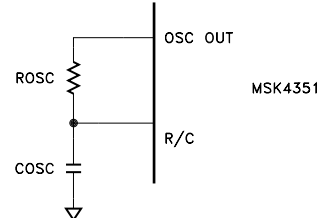

For clock operation below 1MHz:

$$\text{Clock Frequency} = \frac{0.95}{\text{Cosc} \times \text{Rosc}}$$

For clock operation above 1MHz:

$$\text{Clock Frequency} = \frac{0.95}{\text{Cosc} (\text{Rosc} + 30) + 3 \times 10^{-8}}$$

As an alternative, the R/C pin can be driven directly with an HCMOS compatible clock up to 24MHz.

OSCILLATOR FREQUENCY COMPONENT SELECTION FOR MSK4351

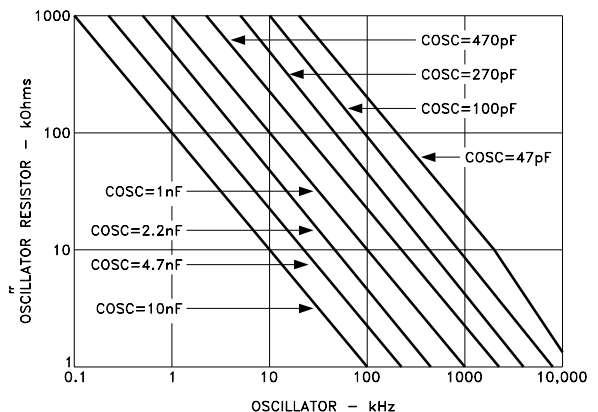

# TYPICAL PERFORMANCE CURVES

FORWARD VOLTAGE DROP vs FORWARD CURRENT

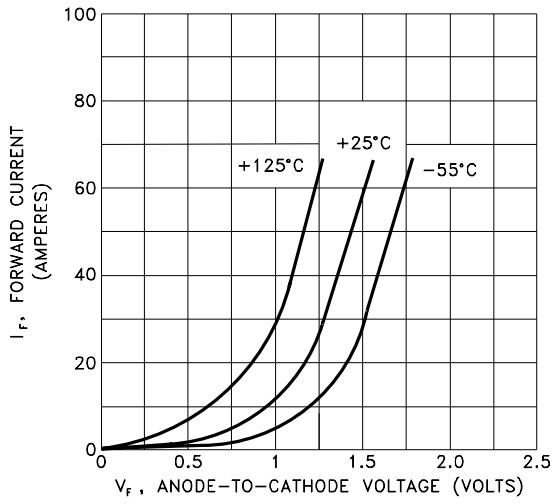

COLLECTOR TO EMITTER VOLTAGE vs. JUNCTION TEMPERATURE

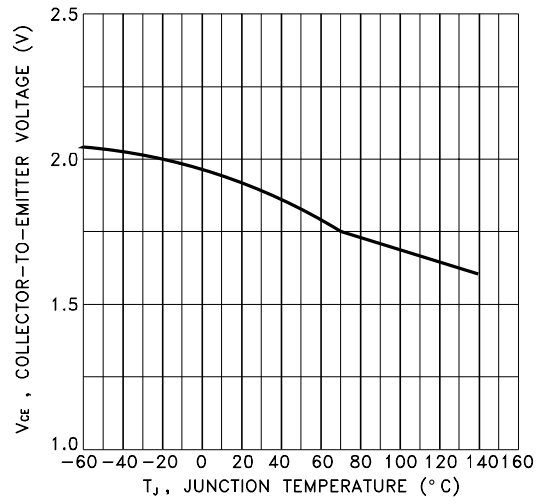

MAXIMUM CONTINUOUS COLLECTOR CURRENT vs CASE TEMPERATURE

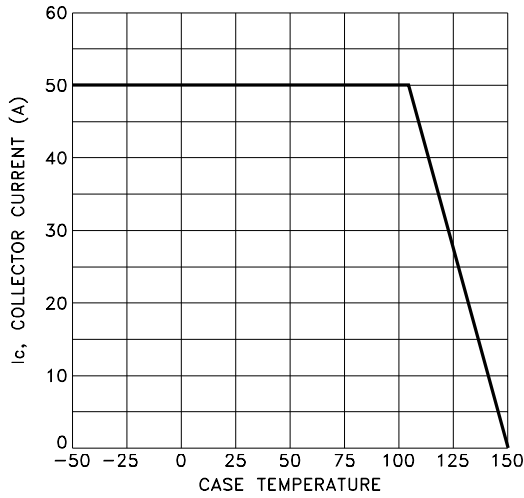

TYPICAL OUTPUT CHARACTERISTICS

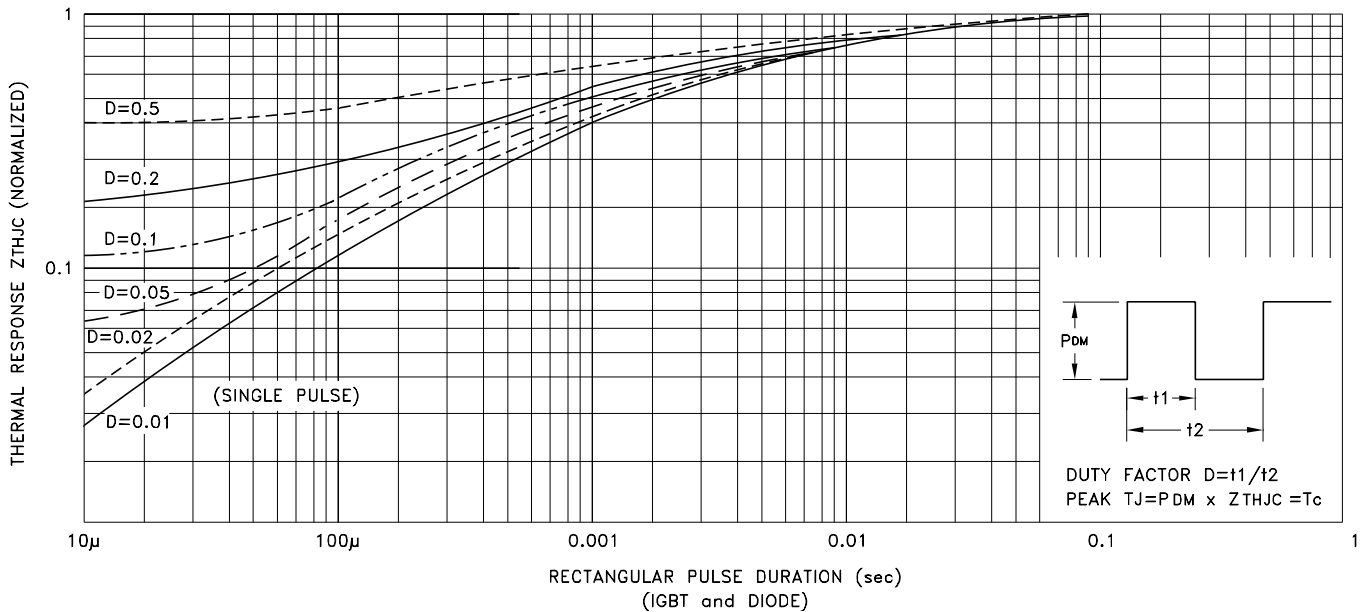
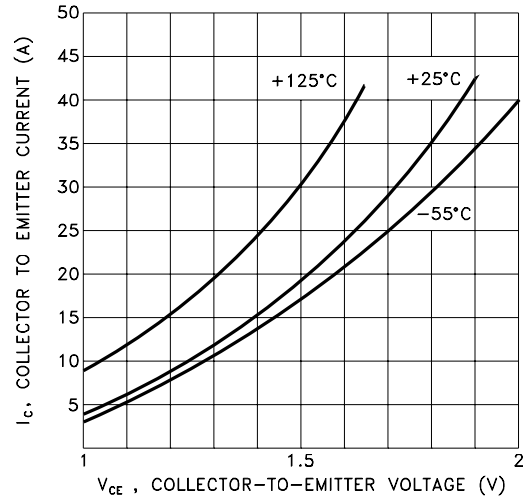

# TYPICAL SYSTEM OPERATION

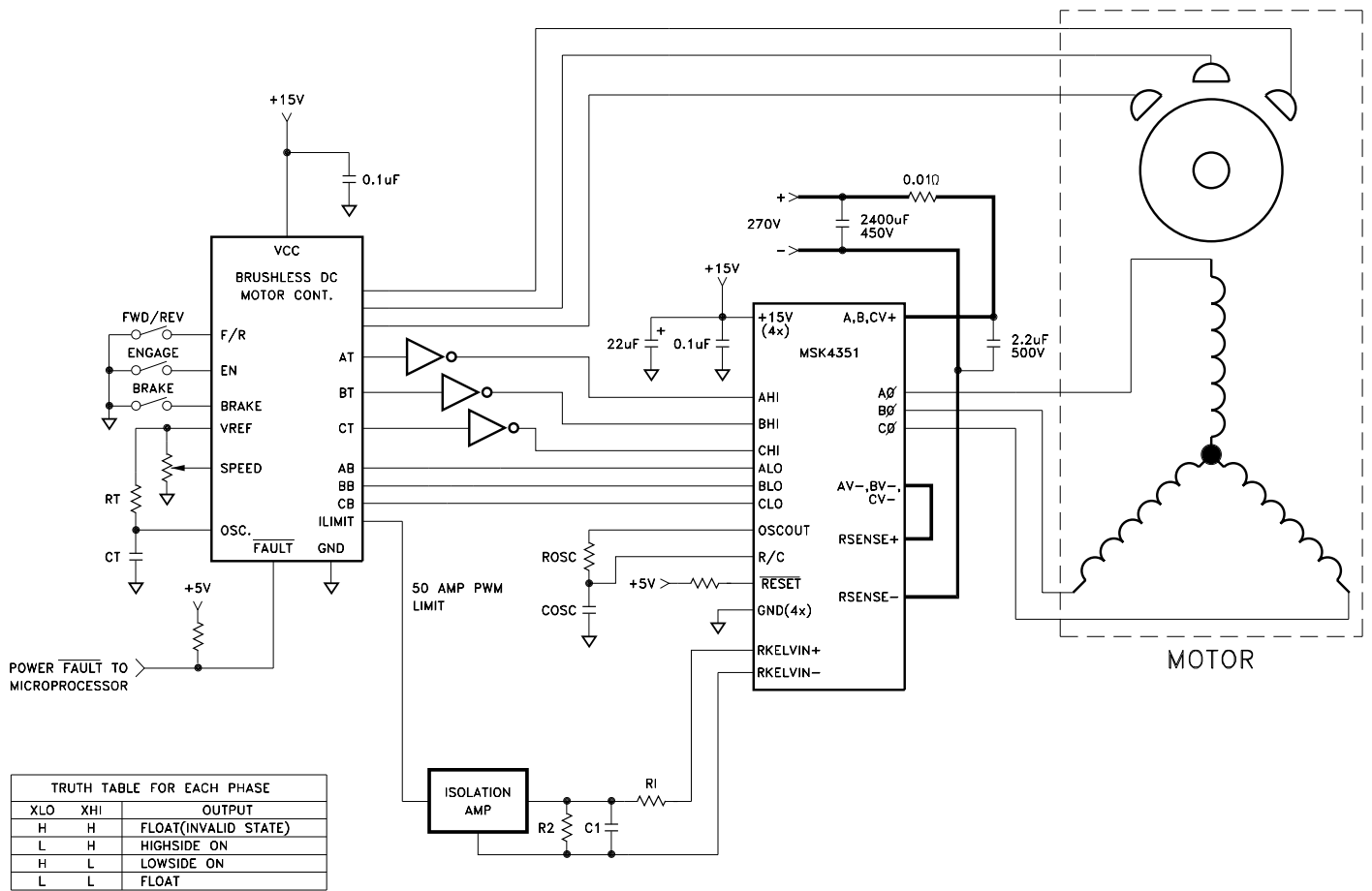

The MSK4351 is designed to be used with a + 270 volt high voltage bus, + 15 volt low power bus, and + 5 volt logic signals. Proper derating should be applied when designing the MSK4351 into a system. High frequency layout techniques with ground planes on a printed circuit board is the only method that should be used for circuit construction. This will prevent pulse jitter caused by excessive noise pickup on the current sense signal or the error amp signal.

Ground planes for the low power circuitry and high power circuitry should be kept separate. The two sections of the hybrid are completely isolated, and can float relative to each other without referencing one to the other. An RC filter will filter out the current spikes and keep the detected noise for that circuit down to a minimum.

The logic signals coming from the typical motor controller IC are set up for driving N channel low side and P channel high side switches directly, and are usually 15 volt levels. Provision should be made for getting 5 volt logic signals to the MSK4351 of the correct assertion levels. Typically, the low side signals out of the controller are high active and the high side are low active. Inverters are shown in the system schematic for the high side controller output.

# MECHANICAL SPECIFICATIONS

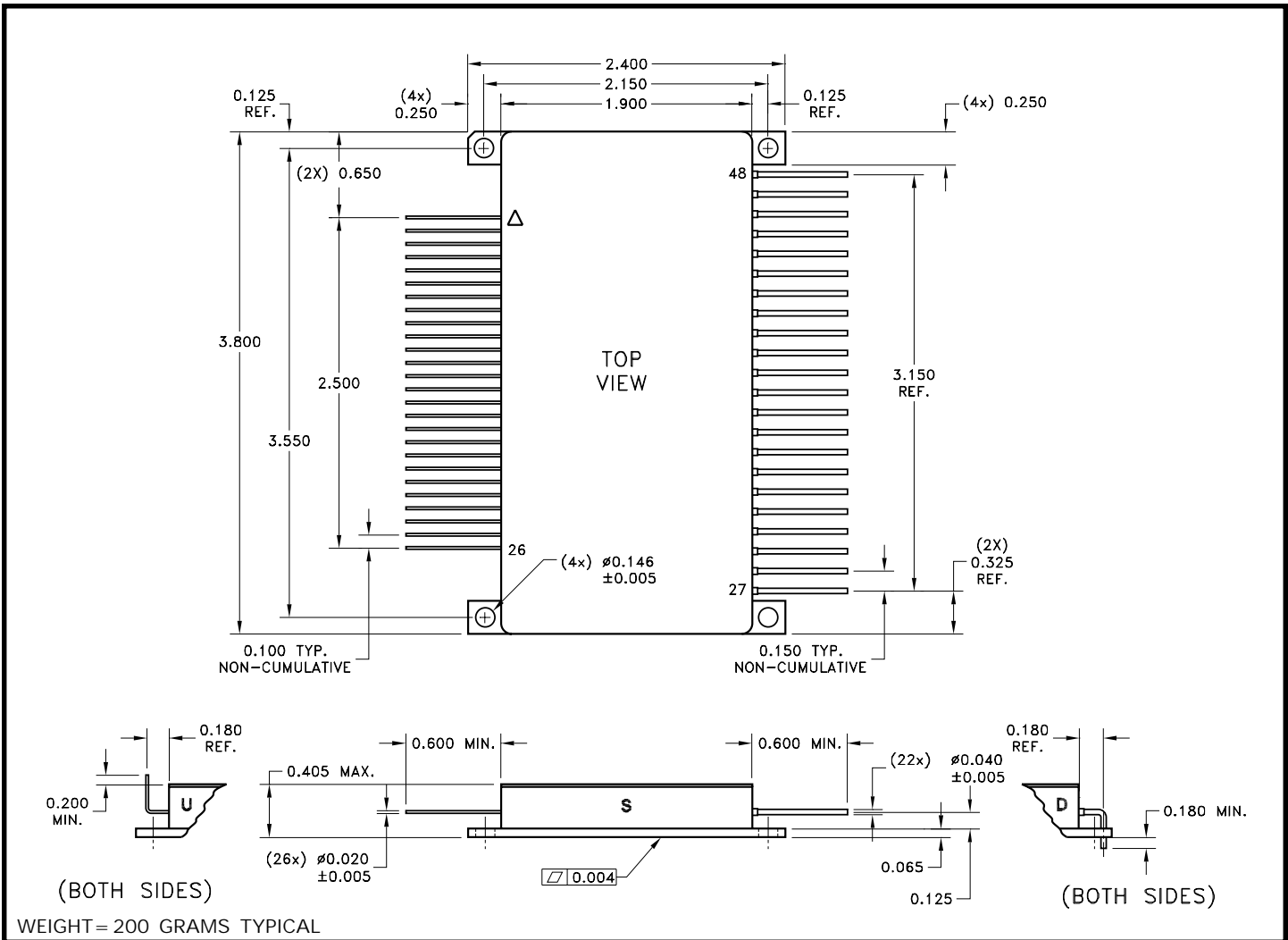

ALL DIMENSIONS ARE  $\pm 0.010$  INCHES UNLESS OTHERWISE LABELED

## ORDERING INFORMATION

**MSK4351 H U**

- LEAD CONFIGURATION  
S = STRAIGHT, U = BENT UP, D = BENT DOWN
- SCREENING  
BLANK = INDUSTRIAL; E = EXTENDED RELIABILITY;  
H = CLASS H (MIL-PRF-38534) SEE NOTE
- GENERAL PART NUMBER

NOTE: THE CENTRIFUGE LEVEL FOR THE CLASS E AND H DEVICE IS 1000G'S

M.S. Kennedy Corp.  
4707 Dey Road Liverpool, New York 13088  
Phone (315) 701-6751  
FAX (315) 701-6752  
www.mskennedy.com

The information contained herein is believed to be accurate at the time of printing. MSK reserves the right to make changes to its products or specifications without notice, however, and assumes no liability for the use of its products. Please visit our website for the most recent revision of this datasheet. Contact MSK for MIL-PRF-38534 qualification status.