



M.S.KENNEDY CORP.

# 200 VOLT 20 AMP MOSFET H-BRIDGE WITH GATE DRIVE

# 4227

4707 Dey Road Liverpool, N.Y. 13088

(315) 701-6751

### FEATURES:

- Low Cost Complete H-Bridge
- 20 Amp Capability, 200 Volt Maximum Rating
- Self-contained Smart Lowside/Highside Drive Circuitry
- Shoot-through Protection
- Isolated Case Allows Direct Heatsinking
- Individual Logic Level Gate Drive Inputs for Various Modulation Schemes

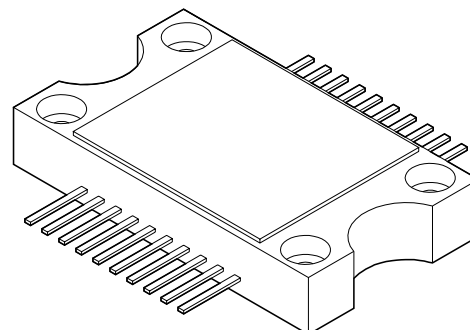

### DESCRIPTION:

The MSK 4227 is a complete H-Bridge circuit to be used for DC brushed motor control or Class D switchmode amplification. All of the drive/control circuitry for the lowside and highside switches are internal to the circuit. Logic level inputs are provided for controlling each MOSFET independently, allowing every possible switch combination except those that would cause a simultaneous conduction or shoot-through condition for each half bridge. This gives the user freedom to use various modulation schemes for PWM control. The MSK 4227 is constructed in a space efficient plastic power package that can be directly bolted to a heatsink.

### EQUIVALENT SCHEMATIC

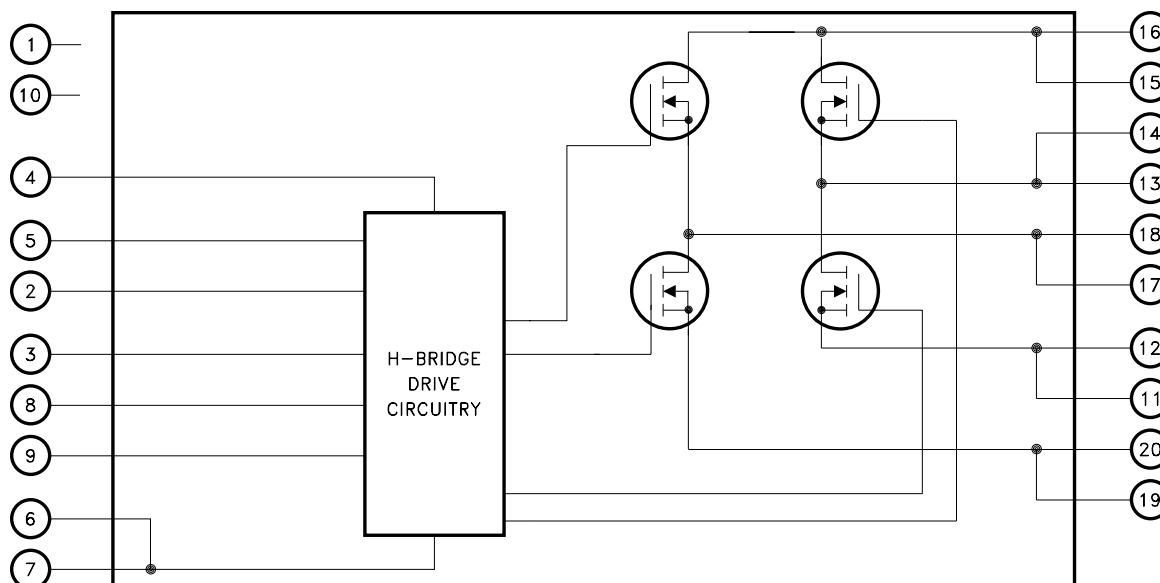

### TYPICAL APPLICATIONS

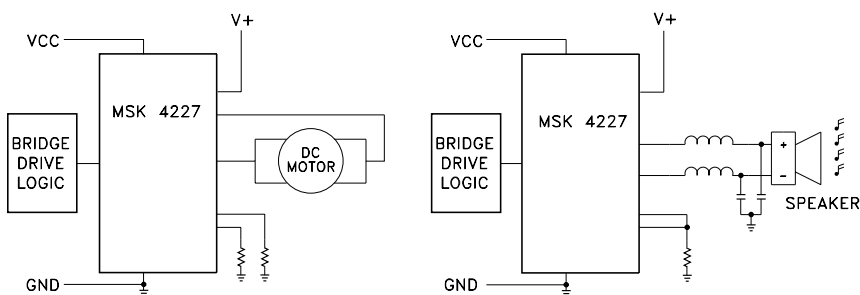

### PIN-OUT INFORMATION

1	NC	20	AV-
2	HINA	19	AV-
3	LINA	18	AØ
4	+ VCC	17	AØ
5	+ VB	16	V+
6	COM	15	V+
7	COM	14	BØ
8	HINB	13	BØ
9	LINB	12	BV-
10	NC	11	BV-

## ABSOLUTE MAXIMUM RATINGS <sup>⑤</sup>

V+	High Voltage Supply <sup>⑥</sup>	200V	T <sub>ST</sub>	Storage Temperature Range	-55° C to + 125° C
+ VCC	Logic Supply	18V	T <sub>LD</sub>	Lead Temperature Range	300° C (10 Seconds)
I <sub>OUT</sub>	Continuous Output Current	20A	T <sub>C</sub>	Case Operating Temperature	MSK4227: -40° C to + 85° C
I <sub>PK</sub>	Peak Output Current	44A	T <sub>J</sub>	Junction Temperature	+ 150° C
θ <sub>JC</sub>	Thermal Resistance (Output Switches @ 125° C)	2.3° C/W			

## ELECTRICAL SPECIFICATIONS

T<sub>c</sub> = + 25° C Unless Otherwise Specified

Parameter	Test Conditions <sup>②</sup>	MSK 4227			Units
		Min.	Typ.	Max.	
<b>OUTPUT CHARACTERISTICS</b>					
R <sub>DS</sub> (ON) <sup>① ④</sup>	Each MOSFET I <sub>D</sub> = 20A	-	-	0.09	Ω
V <sub>DS</sub> (ON) Voltage	Each MOSFET I <sub>D</sub> = 20A <sup>③</sup>	-	1.2	1.8	V
Instantaneous Forward Voltage	Each MOSFET I <sub>S</sub> = 20A Intrinsic Diode <sup>③</sup>	-	1.02	1.2	V
Reverse Recovery Time <sup>①</sup>	Intrinsic Diode	-	-	330	nS
Leakage Current	Each MOSFET V <sub>+</sub> = 200V	-	3.0	250	μA
<b>+ VCC SUPPLY CHARACTERISTICS</b>					
Quiescent Bias Current		-	0.9	3.2	mA
+ VCC Voltage Range <sup>①</sup>		7.4	15	18	V
<b>+ VB SUPPLY CHARACTERISTICS</b>					
Quiescent Bias Current		-	100	300	μA
Bias Current @ 20KHz		-	4	6	mA
+ VB Voltage Range		9.8	15	18	V
<b>LOGIC CONTROL INPUTS, HINA, <math>\overline{\text{LINA}}</math>, HINB, <math>\overline{\text{LINB}}</math> <sup>①</sup></b>					
Input Voltage LO		-	-	0.8	V
Input Voltage HI		2.7	-	-	V
Input Current (V <sub>IN</sub> = 5V)		-	-	20	μA
<b>SWITCHING CHARACTERISTICS <sup>①</sup></b>					
	R <sub>L</sub> = 100Ω				
Rise Time		-	90	-	nS
Fall Time		-	100	-	nS
Dead Time		-	1	-	μS

### NOTES:

- ① Guaranteed by design but not tested. Typical parameters are representative of actual device performance but are for reference only.
- ② + VCC = + 15V, + VB = + 15V, V+ = 100V, AV-, BV- = Ground unless otherwise specified.
- ③ Measured using a 300μS pulse with a 2% Duty Cycle.
- ④ On Resistance is specified for the Internal MOSFET for Thermal Calculations. It does not include the package pin resistance.
- ⑤ Continuous operation at or above absolute maximum ratings may adversely effect the device performance and/or life cycle.
- ⑥ When applying power to the device, apply the low voltage followed by the high voltage or alternatively, apply both at the same time. Do not apply high voltage without low voltage present.

## APPLICATION NOTES

### MSK 4227 PIN DESCRIPTIONS

**+VCC** - Is the low voltage supply for all the internal logic and drivers. A 0.1 $\mu$ F ceramic capacitor in parallel with a 10 $\mu$ F tantalum capacitor is the recommended bypassing from the +VCC pin to the COM pin.

**HINA, HINB** - Are high active logic inputs for signaling the corresponding phase high-side switch to turn on. The logic inputs are compatible with standard CMOS or LSTTL outputs. These logic inputs are internally zener clamped at 5.2 volts.

**LINA, LINB** - Are low active logic inputs for signaling the corresponding phase low-side switch to turn on. The logic inputs are compatible with standard CMOS or LSTTL outputs. These logic inputs are internally zener clamped at 5.2 volts.

**A0, B0** - Are the pins connecting the 3 phase bridge switch options.

**AV-, BV-** - Are the connections from the bottoms of the three half bridges. These pins get connected to the COM pin. If current sensing is desired they may be connected to the COM pin through a low value sense resistor.

**+VB** - Is the connection used to provide power to the floating high-side bootstrap supplies in the gate drive circuitry.

**V+** - Is the high voltage positive rail connection to the tops of the three half bridges. Proper power supply bypassing must be connected from this pin to the COM pin for good filtering. This bypassing must be done as close to the hybrid as possible.

**COM** - Is the connection that all hybrid power supply connections are returned to and bypassed to.

**PWM SCHEMES** - This device does not contain internal high side power supplies. It contains boot strap components only. Any PWM scheme that holds the high side switches on continuously will not work. They must be refreshed at least every 20 milliseconds to recharge the bootstrap capacitance. By turning the high side off momentarily (2 $\mu$ Sec minimum) and turning the low side switch on in the same phase leg, the supply capacitance for driving the high side gate circuitry will be refreshed. This will allow 99.9% duty cycle.

### TYPICAL SYSTEM OPERATION

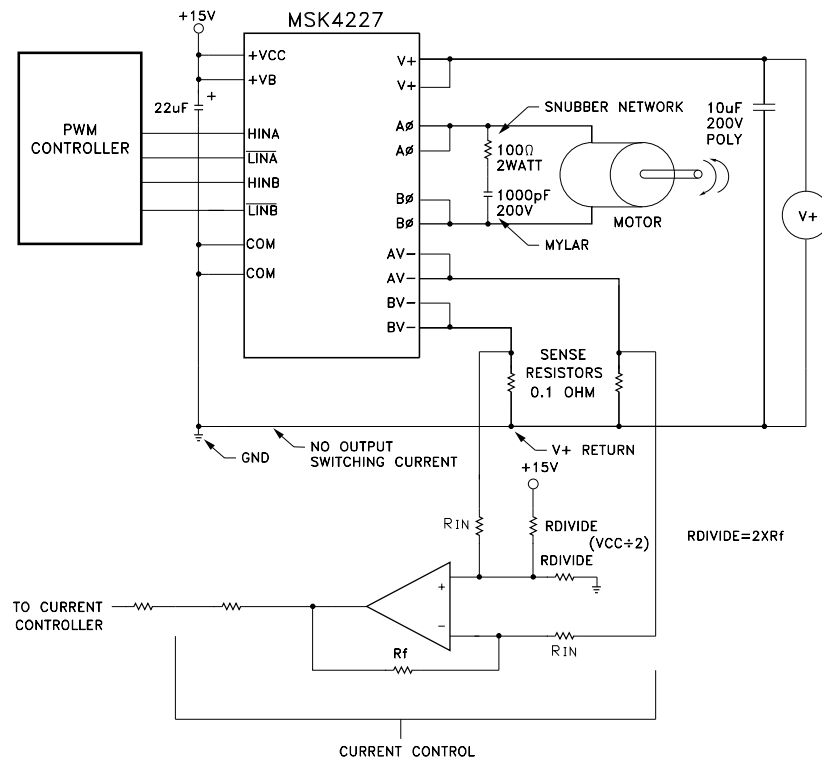

This is a diagram of a typical application of the MSK4227. The design +VCC voltage is +15 volts and should have a good low ESR bypass capacitor such as a tantalum electrolytic. The digital inputs can come from a microprocessor or any type of PWM controller. The controller will use the current sense signal to either control current through PWM, current limit the bridge, or both.

Current sensing is done in this case by a 0.1 ohm sense resistor to sense current from both legs of the bridge separately. It is important to make the high current traces as big as possible to keep inductance down. The storage capacitor connected to the V+ and the module should be large enough to provide the high energy pulse without the voltage sagging too far. A low ESR ceramic capacitor or large polypropylene capacitor will be required. Mount the capacitor as close to the module as possible. The connection between GND and the V+ return should not be carrying any motor current. The sense resistor signal is common mode filtered as necessary to feed the limiting circuitry for the microprocessor. This application will allow full four quadrant torque control for a closed loop servo system. Any modulation scheme may be used, however, but the current sensing scheme may have to change.

A snubber network is usually required, due to the inductance in the power loop. It is important to design the snubber network to suppress any positive spikes above 200V and negative spikes below -2V with respect to ground.

# MECHANICAL SPECIFICATIONS

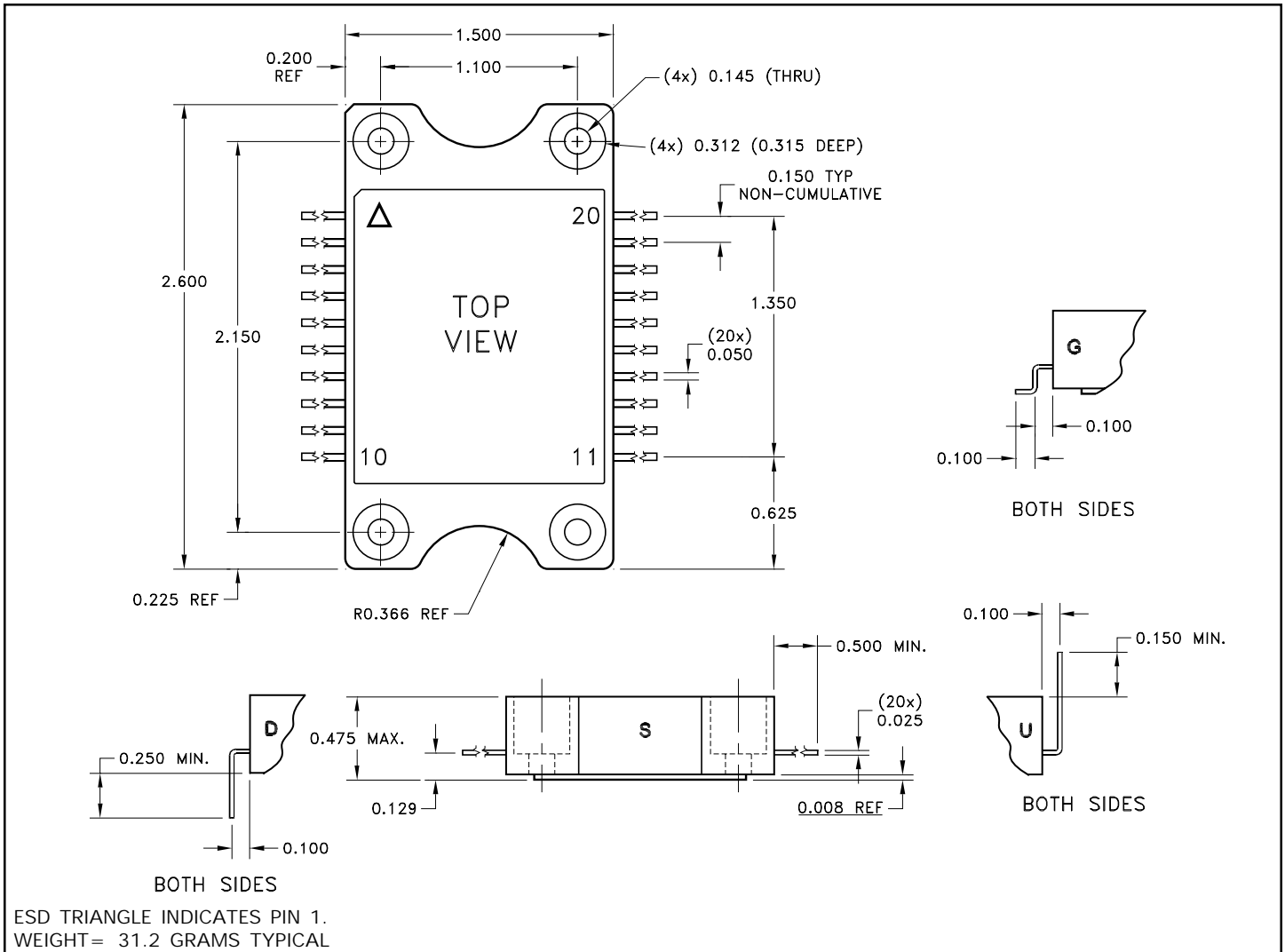

NOTE: ALL DIMENSIONS ARE  $\pm 0.010$  UNLESS OTHERWISE LABELED.

## ORDERING INFORMATION

Part Number	Screening Level	Lead Configuration
MSK4227S	Industrial	Straight
MSK4227D	Industrial	Down
MSK4227U	Industrial	Up
MSK4227G	Industrial	Gull Wing

M.S. Kennedy Corp.  
4704 Dey Road, Liverpool, New York 13088  
Phone (315) 701-6751  
FAX (315) 701-6752  
www.mskennedy.com

The information contained herein is believed to be accurate at the time of printing. MSK reserves the right to make changes to its products or specifications without notice, however, and assumes no liability for the use of its products. Please visit our website for the most recent revision of this datasheet.