



M.S.KENNEDY CORP.

75 VOLT 5 AMP MOSFET H-BRIDGE PWM MOTOR DRIVER/AMPLIFIER

4201

4707 Dey Road Liverpool, N.Y. 13088

(315) 701-6751

FEATURES:

- Low Cost Complete H-Bridge
- 28 Volt, 5 Amp Capability, 75 Volt Maximum Rating
- Self-contained Smart Lowside/Highside Drive Circuitry
- Internal Deadtime Generation, Shoot-through Protection
- Output Disable/Shutdown Capability
- Isolated Case Allows Direct Heatsinking
- Four Quadrant Operation, Torque Control Capability
- Available Fully Screened To MIL-PRF-38534
- Replaces SA-51

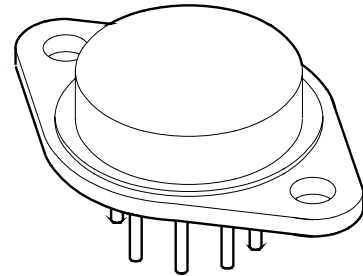

DESCRIPTION:

The MSK 4201 is a complete H-Bridge hybrid to be used for DC brushed motor control or Class D switchmode amplifier. All of the drive/control circuitry for the lowside and highside switches are internal to the hybrid. The user provides a TTL compatible PWM signal for simultaneous amplitude and direction control in four quadrant mode. The internal drive circuitry will provide proper deadtime/shoot-through protection for each half-bridge. All N-channel FETs mean the best efficiency for the size, both in terms of on-resistance and switching capability. For an idle/sleep mode, or for fault protection, a TTL compatible disable pin is provided so as to shut down all four transistors. The MSK 4201 is packaged in a space efficient isolated 8 pin TO-3 that can be directly connected to a heatsink.

EQUIVALENT SCHEMATIC

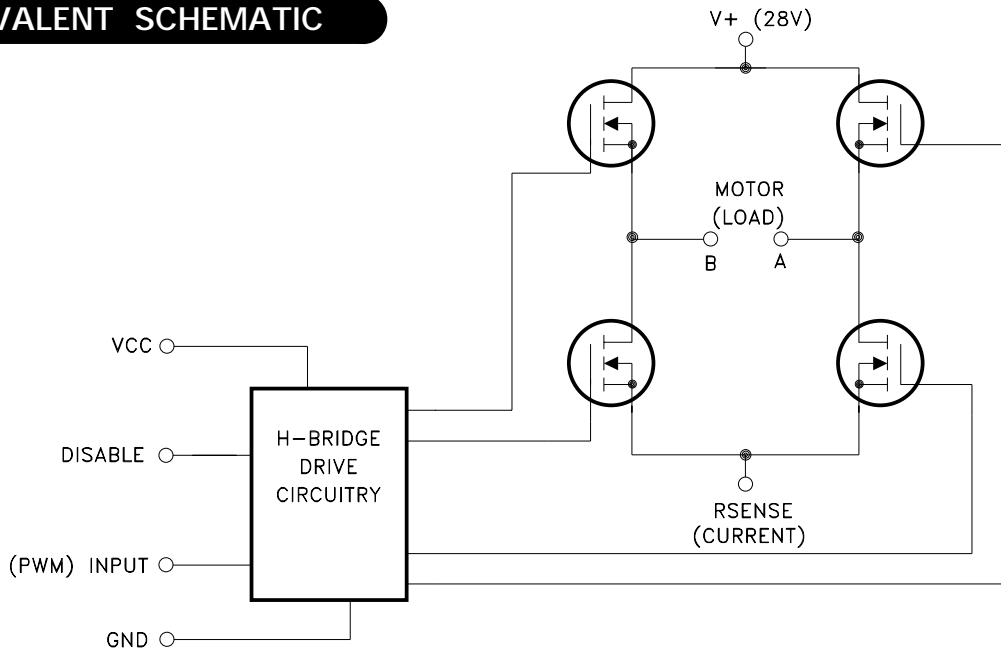

TYPICAL APPLICATIONS

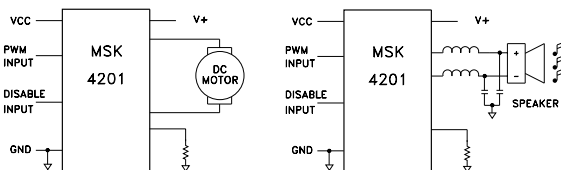

PIN-OUT INFORMATION

- | | |
|-----------|-----------|
| 1 V+ | 5 GND |
| 2 MOTOR B | 6 INPUT |
| 3 VCC | 7 MOTOR A |
| 4 DISABLE | 8 RSENSE |

ABSOLUTE MAXIMUM RATINGS ^⑥

V+	High Voltage Supply ^⑦	75V
V _{CC}	Logic Supply	16V
I _{OUT}	Continuous Output Current	5A
I _{PK}	Peak Output Current	37A
V _{OUT}	Output Voltage Range	GND-2V min. To V+ max.
θ _{JC}	Thermal Resistance @ 125°C Case	2.3°C/W (Output Switches)

T _{ST}	Storage Temperature Range	-65°C to +150°C
T _{LD}	Lead Temperature Range	300°C (10 Seconds)
T _C	Case Operating Temperature	MSK4201 -40°C to +125°C MSK4201B/E -55°C to +125°C
T _J	Junction Temperature	+175°C

ELECTRICAL SPECIFICATIONS

All Ratings: T_C = +25°C Unless Otherwise Specified

Parameter	Test Conditions	Subgroup Group A ^⑤	MSK 4201B/E ^③			MSK 4201 ^②			Units
			Min.	Typ.	Max.	Min.	Typ.	Max.	
OUTPUT CHARACTERISTICS									
V _{DS(ON)} Voltage (Each MOSFET)	I _D = 5A	1	-	1.5	1.8	-	1.5	2.16	V
		2	-	2.2	2.4	-	-	-	V
		3	-	1.1	1.2	-	-	-	V
Instantaneous Forward Voltage, Each MOSFET (Intrinsic Diode)	I _S = 5A ^①	1	-	1.0	2.1	-	1.0	2.2	V
		2	-	0.9	2.0	-	-	-	V
		3	-	1.1	2.2	-	-	-	V
Reverse Recovery Time (Intrinsic Diode) ^①		-	-	-	240	-	-	240	nS
Leakage Current, Each MOSFET	V ₊ = 70V	1	-	-	25	-	-	30	uA
	V ₊ = 70V	2	-	-	250	-	-	-	uA
	V ₊ = 70V	3	-	-	25	-	-	-	uA
VCC SUPPLY CHARACTERISTICS									
VCC Supply Voltage Range		-	10	12	15	10	12	15	V
Quiescent Logic Current	V _{CC} = 12V (non-switching)	1	-	11	18	-	11	21	mA
		2	-	11	18	-	-	-	mA
		3	-	11	18	-	-	-	mA
INPUT SIGNALS CHARACTERISTICS									
Threshold Voltage ^①	V _{CC} = 12V	1,2,3	0.8	1.5	2.7	0.8	1.5	2.7	V
SWITCHING CHARACTERISTICS V ₊ = 28V, V _{CC} = 12V, I _C = 2A									
Turn-On Propagation Delay (Includes Deadtime)		-	-	160	240	-	160	-	nS
Turn-Off Propagation Delay		-	-	85	128	-	85	-	nS
Rise-Time		-	-	36	54	-	36	-	nS
Fall-Time		-	-	170	255	-	170	-	nS
Dead-Time		-	-	100	-	-	100	-	nS

NOTES:

- ① Guaranteed by design but not tested. Typical parameters are representative of actual device performance but are for reference only.
- ② Industrial grade and "E" suffix devices shall be tested to subgroups 1 and 4 unless otherwise specified.
- ③ Military grade devices ("B" suffix) shall be 100% tested to subgroups 1,2,3 and 4.
- ④ Subgroups 5 and 6 testing available upon request.
- ⑤ Subgroup 1,4 T_A = T_C = +25°C
2 T_A = T_C = +125°C
3 T_A = T_C = -55°C
- ⑥ Continuous operation at or above absolute maximum ratings may adversely effect the device performance and/or life cycle.
- ⑦ When applying power to the device, apply the low voltage followed by the high voltage or alternatively, apply both at the same time. Do not apply high voltage without low voltage present.

APPLICATION NOTES

MSK 4201 PIN DESCRIPTION

VCC - Is the low voltage supply for powering internal logic and drivers for the lowside and highside MOSFETS. The supplies for the highside drivers are derived from this voltage.

V+ - Is the higher voltage H-bridge supply. The MOSFETS obtain the drive current from this supply pin. The voltage on this pin is limited by the drive IC. The MOSFETS are rated at 100 volts. Proper by-passing to **GND** with sufficient capacitance to suppress any voltage transients, and to ensure removing any drooping during switching, should be done as close to the pins on the hybrid as possible.

MOTOR A - Is the output pin for one half of the bridge. When the PWM input is high, this output will be pulled up to V+ .

MOTOR B - Is the output pin for the other half of the bridge. When the PWM input is low, this output will be pulled up to V+ .

RSENSE - This is the common connection for the bottom of the bridge. This can have a sense resistor connection to the V+ return ground for current limit sensing, or can be connected directly to ground. The maximum voltage on this pin is ± 2 volts with respect to GND.

GND - Is the return connection for the input logic and Vcc.

PWM INPUT - Is a TTL compatible input pin for providing the PWM signal to modulate the output switches. The duty cycle can be between 0% (DC Low) and 100% (DC High). See typical system operation notes.

DISABLE INPUT - Is a TTL compatible input for providing a shutdown signal to the hybrid for disabling all four switches in the bridge regardless of the PWM input level. A digital 1 disables, a digital 0 enables.

TYPICAL SYSTEM OPERATION

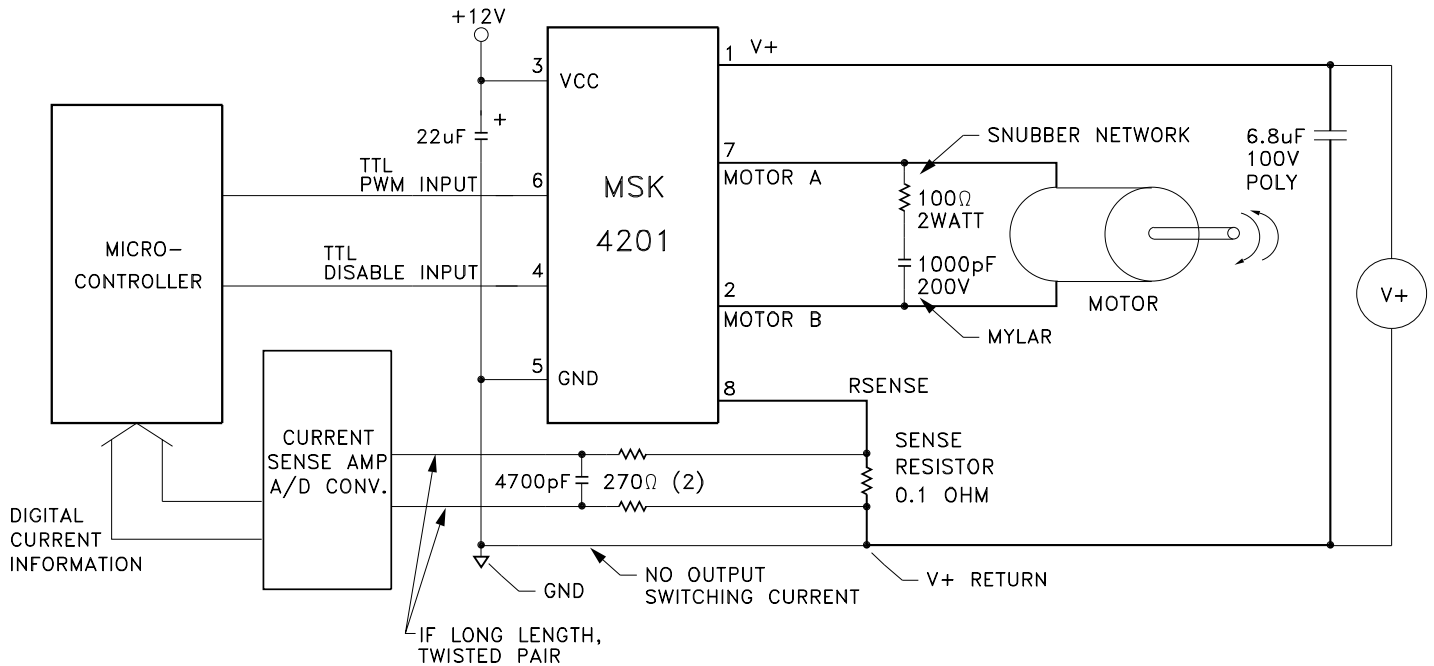

This is a diagram of a typical application of the MSK 4201. The design Vcc voltage is + 12 volts and should have a good low ESR bypass capacitor such as a tantalum. The PWM and DISABLE signals are typically provided by some type of microprocessor control. The PWM signal will be a TTL signal with a pulse frequency required by the system, and pulse duty cycles according to the required direction/speed. A 0% duty cycle (continuous TTL low) will mean full voltage to the motor in one direction. A 100% duty cycle (continuous TTL high) will mean full voltage to the motor in the other direction. A 50% duty cycle will hold the motor at 0 RPM.

Current sensing is done in this case by a 0.1 ohm sense resistor to sense current from either leg of the bridge. It is important to make the high current traces as wide as possible to keep inductance down. The storage capacitor connected to the V+ and the hybrid should be large enough to provide the high energy pulse without the voltage sagging too far. The storage capacitor should be a low ESR ceramic capacitor or large polypropylene capacitor. Mount capacitor as close to the hybrid as possible. The connection between GND and the V+ return should not be carrying any motor current. The sense resistor signal is common mode filtered as necessary to feed the limiting circuitry for the microprocessor. This application will allow full four quadrant torque control for a closed loop servo system.

A snubber network is usually required, due to the inductance in the power loop. It is important to design the snubber network to suppress any positive spikes above 75V and negative spikes below -2V with respect to pin 5 (gnd) of the hybrid.

MECHANICAL SPECIFICATIONS

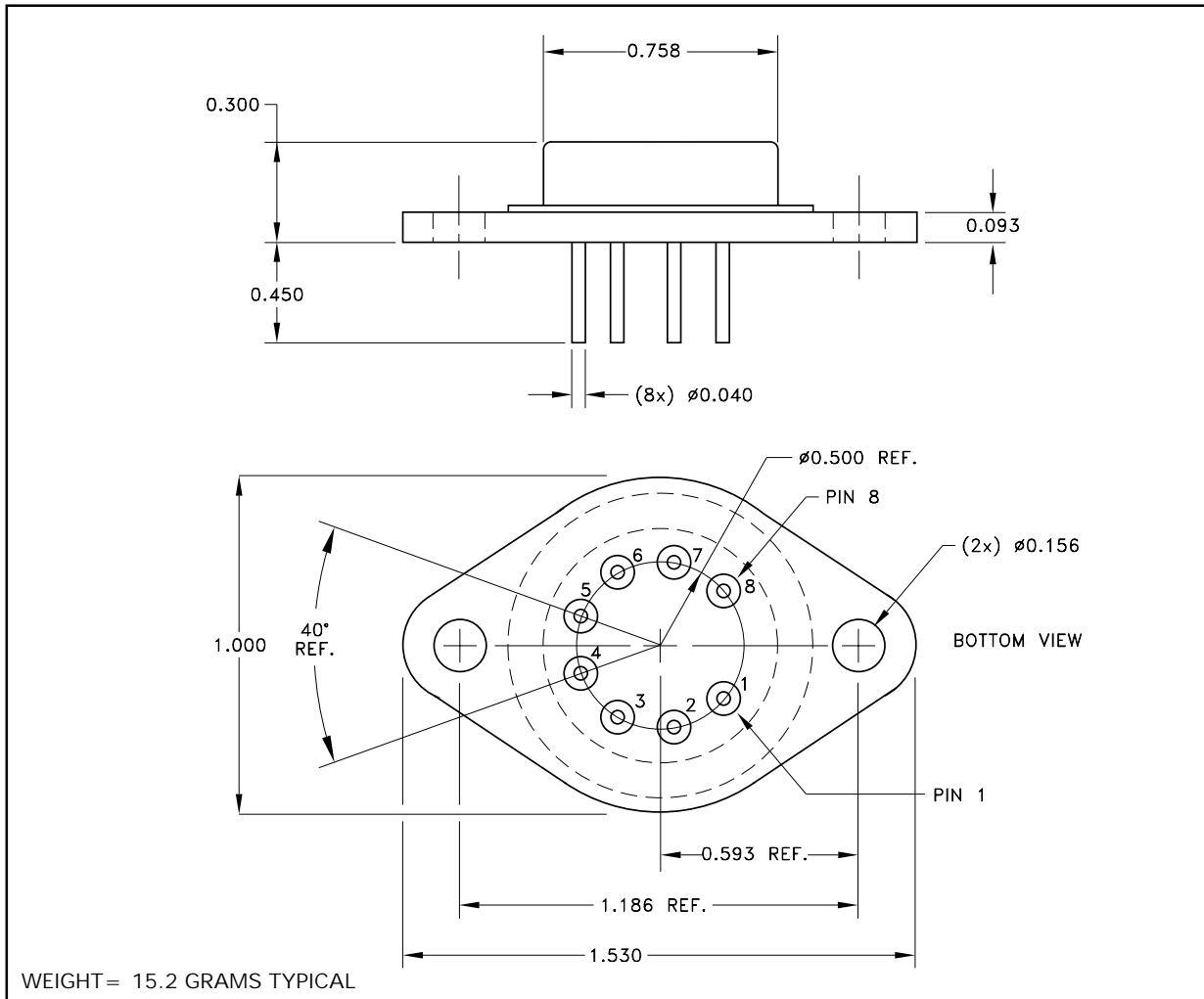

ALL DIMENSIONS ARE ± 0.01 INCHES UNLESS OTHERWISE LABELED

ORDERING INFORMATION

Part Number	Screening Level
MSK4201	Industrial
MSK4201E	Extended Reliability
MSK4201B	Mil-PRF-38534 Class H

M.S. Kennedy Corp.
 4707 Dey Road, Liverpool, New York 13088
 Phone (315) 701-6751
 FAX (315) 701-6752
www.mskennedy.com

The information contained herein is believed to be accurate at the time of printing. MSK reserves the right to make changes to its products or specifications without notice, however, and assumes no liability for the use of its products. Please visit our website for the most recent revision of this datasheet.