



M.S.KENNEDY CORP.

H-BRIDGE MOSFET POWER MODULE

3014

4707 Dey Road Liverpool, N.Y. 13088

(315) 701-6751

FEATURES:

- P and N Channel MOSFETs for Ease of Drive
- 100 Volt, 10 Amp Full H-Bridge
- Isolated Package for Direct Heat Sinking, Excellent Thermal Conductivity
- Avalanche Rated Devices

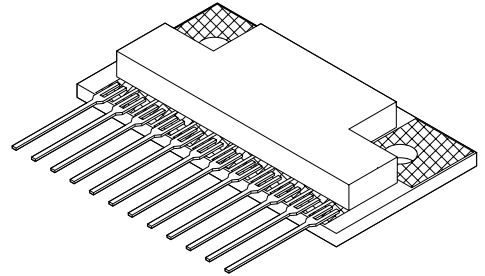

DESCRIPTION:

The MSK 3014 is an H-bridge power circuit packaged in a space efficient isolated ceramic tab power SIP package. The MSK 3014 consists of P-Channel MOSFETs for the top transistors and N-Channel MOSFETs for the bottom transistors. The MSK 3014 uses M.S. Kennedy's proven power hybrid technology to bring a cost effective high performance circuit for use in today's sophisticated servo motor and disk drive systems.

EQUIVALENT SCHEMATIC

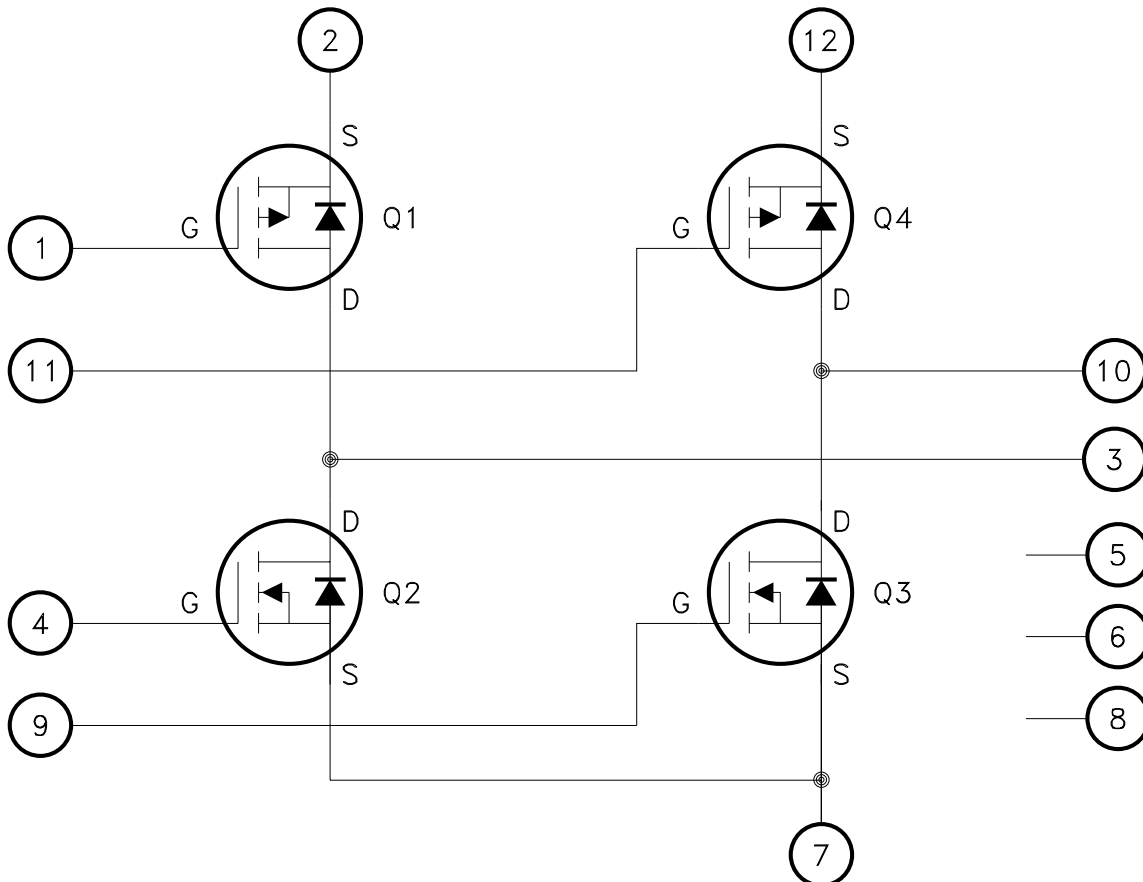

TYPICAL APPLICATIONS

- Stepper Motor Servo Control
- Disk Drive Head Control
- X-Y Table Control
- Az-El Antenna Control

PIN-OUT INFORMATION

- | | |
|-------------|--------------|
| 1 Gate Q1 | 12 Source 4 |
| 2 Source Q1 | 11 Gate Q4 |
| 3 Drain 1,2 | 10 Drain 3,4 |
| 4 Gate Q2 | 9 Gate Q3 |
| 5 N/C | 8 N/C |
| 6 N/C | 7 Source 2,3 |

ABSOLUTE MAXIMUM RATINGS

V _{DS}	Drain to Source Voltage	100V MAX
V _{DGDR}	Drain to Gate Voltage (R _{GS} = 1MΩ)	100V MAX
V _{GS}	Gate to Source Voltage (Continuous)	± 20V MAX
I _D	Continuous Current	10A MAX
I _{DM}	Pulsed Current	25A MAX
	Single Pulse Avalanche Energy (Q1,Q4)	7.9mJ
	(Q2,Q3)	7.9mJ

T _J	Junction Temperature	+ 175°C MAX
T _{ST}	Storage Temperature	-55°C to + 150°C
T _C	Case Operating Temperature Range	-55°C to + 125°C
T _{LD}	Lead Temperature Range (10 Seconds)	300°C MAX
R _{TH-JC}	Thermal Resistance (Junction to Case)	
	P-Channel @ 25°C	5.2°C/W
	P-Channel @ 125°C	8.0°C/W
	N-Channel @ 25°C	6.0°C/W
	N-Channel @ 125°C	9.1°C/W

ELECTRICAL SPECIFICATIONS

Parameter	Test Conditions ④	MSK3014			Units
		Min.	Typ.	Max.	
Drain-Source Breakdown Voltage	V _{GS} = 0 I _D = 0.25mA (All Transistors)	100	-	-	V
Drain-Source Leakage Current	V _{DS} = 100V V _{GS} = 0V (Q2,Q3)	-	-	25	μA
	V _{DS} = -100V V _{GS} = 0V (Q1,Q4)	-	-	-25	μA
Gate-Source Leakage Current	V _{GS} = ± 20V V _{DS} = 0 (All Transistors)	-	-	± 100	nA
Gate-Source Threshold Voltage	V _{DS} = V _{GS} I _D = 250μA (Q2,Q3)	2.0	-	4.0	V
	V _{DS} = V _{GS} I _D = 250μA (Q1,Q4)	2.0	-	4.0	V
Drain-Source On Resistance ②	V _{GS} = 10V I _D = 9.0A (Q2,Q3)	-	-	0.20	Ω
	V _{GS} = -10V I _D = -8.4A (Q1,Q4)	-	-	0.28	Ω
Drain-Source On Resistance ③	V _{GS} = 10V I _D = 9.0A (Q2,Q3)	-	-	0.11	Ω
	V _{GS} = 10V I _D = -8.4A (Q1,Q4)	-	-	0.20	Ω
Forward Transconductance ①	V _{DS} = 50V I _D = 9.0A (Q2,Q3)	6.4	-	-	S
	V _{DS} = -50V I _D = -8.4A (Q1,Q4)	3.2	-	-	S
N-Channel (Q2,Q3)					
Total Gate Charge ①	I _D = 9.0A	-	-	44	nC
Gate-Source Charge ①	V _{DS} = 80V	-	-	6.2	nC
Gate-Drain Charge ①	V _{GS} = 10V	-	-	21	nC
Turn-On Delay Time ①	V _{DD} = 50V	-	6.4	-	nS
Rise Time ①	I _D = 9.0A	-	27	-	nS
Turn-Off Delay Time ①	R _G = 12Ω	-	37	-	nS
Fall Time ①	R _D = 5.5Ω	-	25	-	nS
Input Capacitance ①	V _{GS} = 0V	-	640	-	pF
Output Capacitance ①	V _{DS} = 25V	-	160	-	pF
Reverse Transfer Capacitance ①	f = 1.0MHz	-	88	-	pF
P-CHANNEL (Q1,Q3,Q5)					
Total Gate Charge ①	I _D = -8.4A	-	-	58	nC
Gate-Source Charge ①	V _{DS} = -80V	-	-	8.3	nC
Gate-Drain Charge ①	V _{GS} = -10V	-	-	32	nC
Turn-On Delay Time ①	V _{DD} = -50V	-	15	-	nS
Rise Time ①	I _D = -8.4A	-	58	-	nS
Turn-Off Delay Time ①	R _G = 9.1Ω	-	45	-	nS
Fall Time ①	R _D = 6.2Ω	-	46	-	nS
Input Capacitance ①	V _{GS} = 0V	-	760	-	pF
Output Capacitance ①	V _{DS} = -25V	-	260	-	pF
Reverse Transfer Capacitance ①	f = 1.0MHz	-	170	-	pF
BODY DIODE					
Forward On Voltage ①	I _S = 9.0A V _{GS} = 0V (Q2,Q3)	-	1.3	-	V
	I _S = -8.4A V _{GS} = 0V (Q1,Q4)	-	-1.6	-	V
Reverse Recovery Time ①	I _S = 9.0A di/dt = 100A/μS (Q2,Q3)	-	130	190	nS
	I _S = -8.4A di/dt = 100A/μS (Q1,Q4)	-	130	190	nS
Reverse Recovery Charge ①	I _S = 9.0A di/dt = 100A/μS (Q2,Q3)	-	650	970	μC
	I _S = -8.4A di/dt = 100A/μS (Q1,Q4)	-	650	970	μC

NOTES:

- ① This parameter is guaranteed by design but need not be tested. Typical parameters are representative of actual device performance but are for reference only.
- ② Resistance as seen at package pins.
- ③ Resistance for die only; use for thermal calculations.
- ④ T_A = 25 °C unless otherwise specified.

APPLICATION NOTES

N-CHANNEL GATES (Q2, Q3)

For driving the N-Channel gates, it is important to keep in mind that it is essentially like driving a capacitance to a sufficient voltage to get the channel fully on. Driving the gates to +15 volts with respect to their sources assures that the transistors are on. This will keep the dissipation down to a minimum level [$R_{DS(ON)}$ specified in the data sheet]. How quickly the gate gets turned ON and OFF will determine the dissipation of the transistor while it is transitioning from OFF to ON, and vice-versa. Turning the gate ON and OFF too slow will cause excessive dissipation, while turning it ON and OFF too fast will cause excessive switching noise in the system. It is important to have as low a driving impedance as practical for the size of the transistor. Many motor drive IC's have sufficient gate drive capability for the MSK 3014. If not, paralleled CMOS standard gates will usually be sufficient. A series resistor in the gate circuit slows it down, but also suppresses any ringing caused by stray inductances in the MOSFET circuit. The selection of the resistor is determined by how fast the MOSFET wants to be switched. See Figure 1 for circuit details.

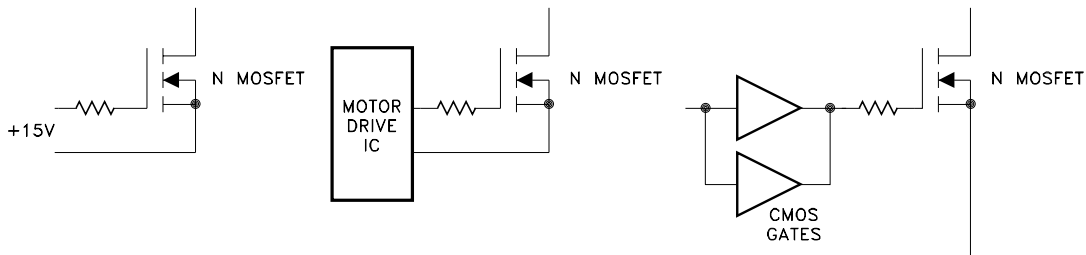

Figure 1

P-CHANNEL GATES (Q1, Q4)

Most everything applies to driving the P-Channel gates as the N-Channel gates. The only difference is that the P-Channel gate to source voltage needs to be negative. Most motor drive IC's are set up with an open collector or drain output for directly interfacing with the P-channel gates. If not, an external common emitter switching transistor configuration (see Figure 2) will turn the P-Channel MOSFET on. All the other rules of MOSFET gate drive apply here. For high supply voltages, additional circuitry must be used to protect the P-Channel gate from excessive voltages.

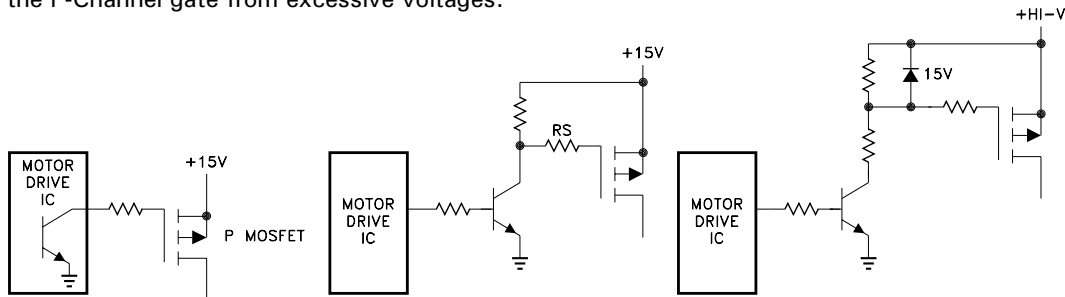

Figure 2

BRIDGE DRIVE CONSIDERATIONS

It is important that the logic used to turn ON and OFF the various transistors allow sufficient "dead time" between a high side transistor and its low side transistor to make sure that at no time are they both ON. When they are, this is called "shoot-through", and it places a momentary short across the power supply. This overly stresses the transistors and causes excessive noise as well. See Figure 3.

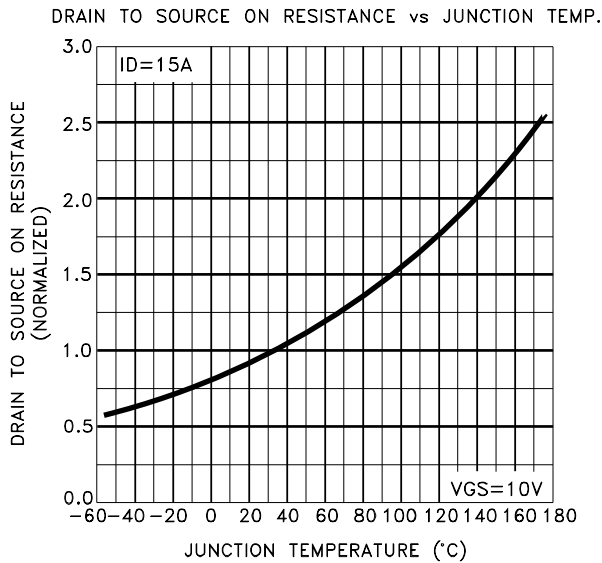
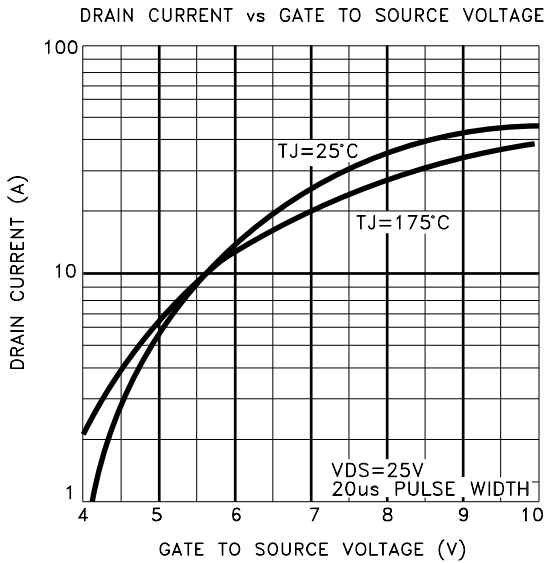
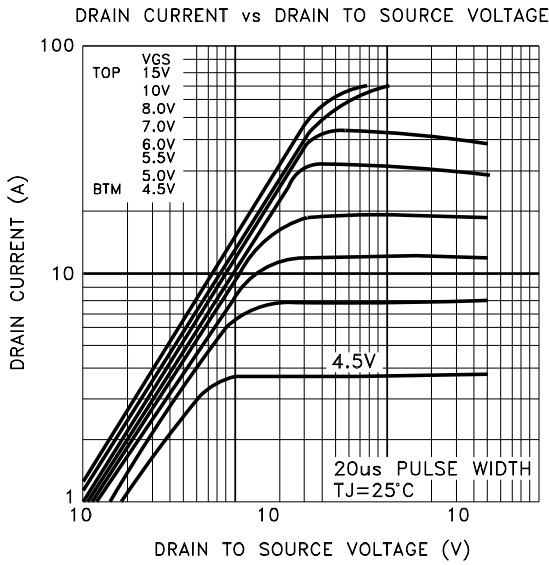

Figure 3

This deadtime should allow for the turn on and turn off time of the transistors, especially when slowing them down with gate resistors. This situation will be present when switching motor direction, or when sophisticated timing schemes are used for servo systems such as locked antiphase PWM'ing for high bandwidth operation.

TYPICAL PERFORMANCE CURVES

N-CHANNEL DEVICES (Q2,Q3)



P-CHANNEL DEVICES (Q1,Q4)

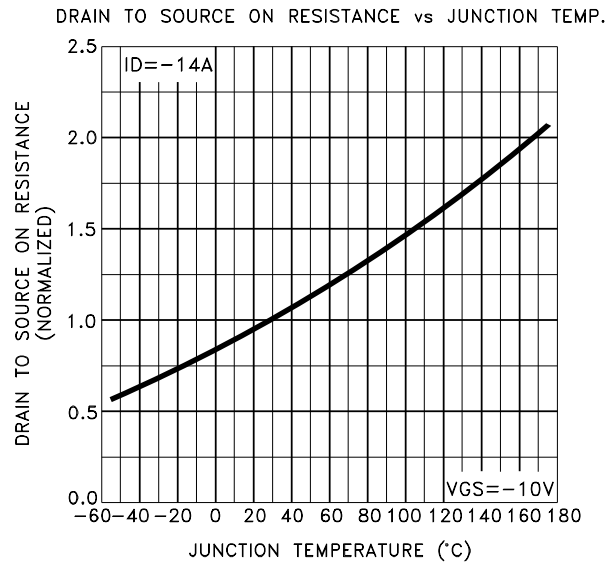
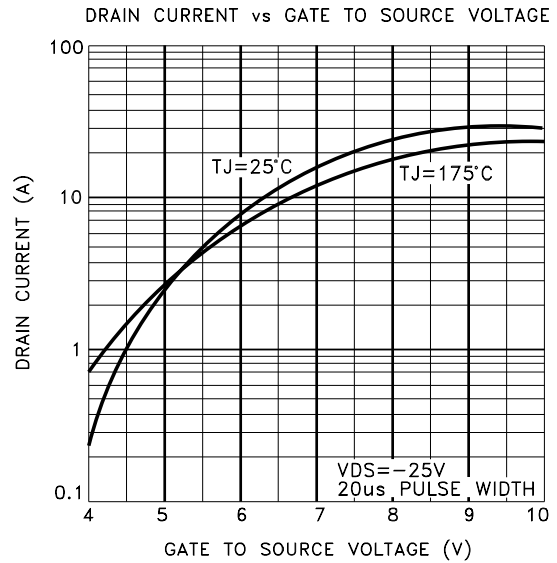
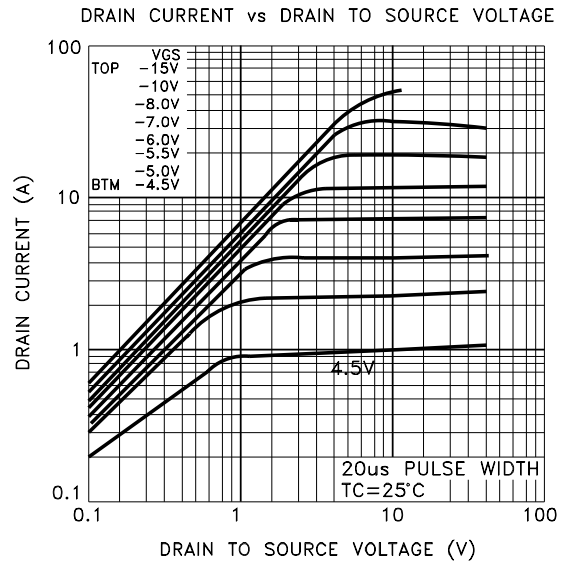

MECHANICAL SPECIFICATIONS

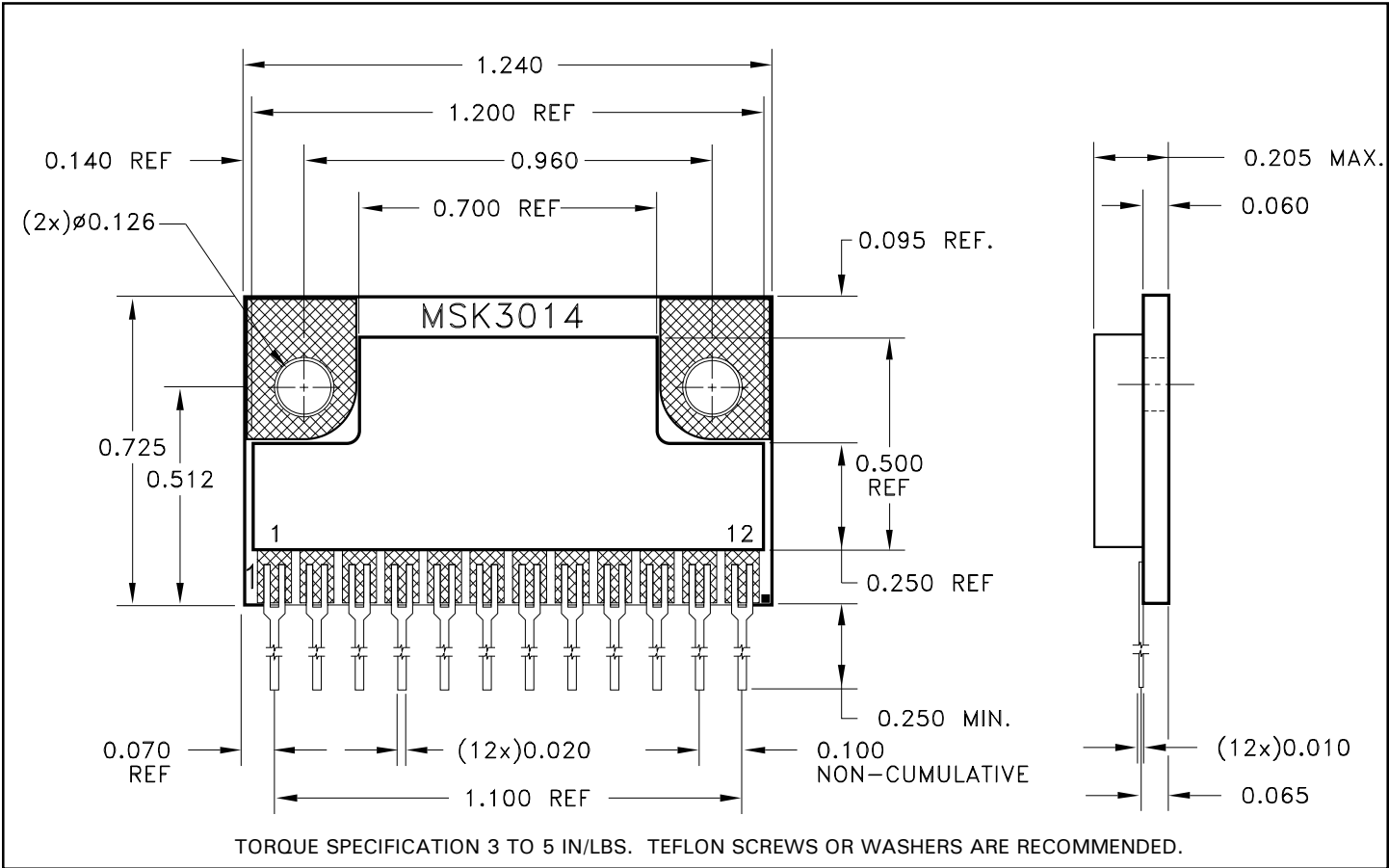

ALL DIMENSIONS ARE ±0.010 INCHES UNLESS OTHERWISE LABELED.

ORDERING INFORMATION

PART NUMBER	SCREENING LEVEL
MSK 3014	Industrial

M.S. Kennedy Corp.
 4707 Dey Road, Liverpool, New York 13088
 Phone (315) 701-6751
 FAX (315) 701-6752
 www.mskennedy.com

The information contained herein is believed to be accurate at the time of printing. MSK reserves the right to make changes to its products or specifications without notice, however, and assumes no liability for the use of its products.