



QUAD N-CHANNEL MOSFET POWER MODULE

3013

M.S.KENNEDY CORP.

4707 Dey Road Liverpool, N.Y. 13088

(315) 701-6751

FEATURES:

- Pin Compatible with MPM3013
- QUAD Independent N - Channel MOSFETS
- Isolated Package for Direct Heat Sinking, Excellent Thermal Conductivity
- Avalanche Rated Devices
- 55 Volt, 25 Amp Rated
- Low RDS (ON) - 0.022Ω For Each Die

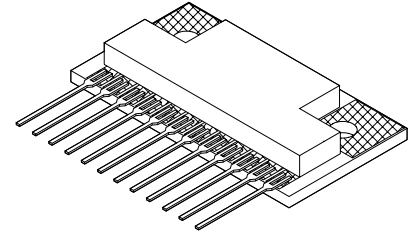

DESCRIPTION:

The MSK 3013 is a QUAD N-Channel power circuit packaged in a space efficient isolated ceramic tab power SIP package. The MSK 3013 consists of four totally isolated N-Channel MOSFETS. The MSK 3013 uses M.S.Kennedy's proven power hybrid technology to bring a cost effective high performance circuit for use in today's sophisticated servo motor and disk drive systems. The MSK 3013 is a replacement for the MPM3013 with only minor differences in specifications.

EQUIVALENT SCHEMATIC

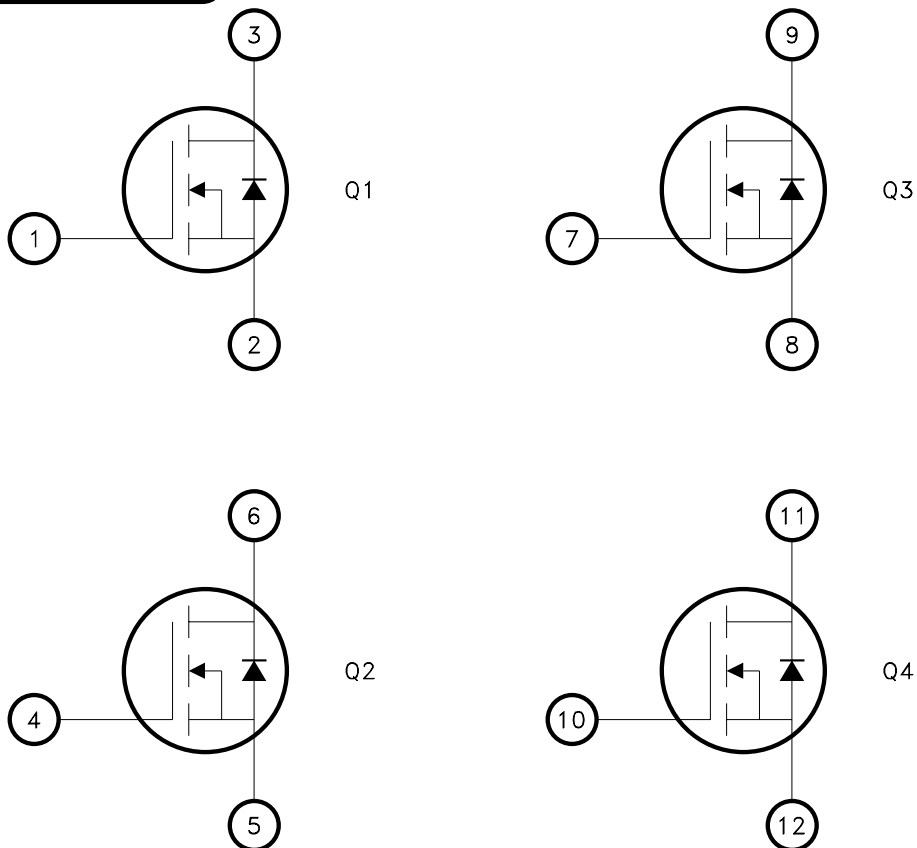

TYPICAL APPLICATIONS

- Stepper Motor Servo Control
- Disk Drive Head Control
- X-Y Table Control
- Az-El Antenna Control
- Various Switching Applications

PIN-OUT INFORMATION

1	Q1 Gate	7	Q3 Gate
2	Q1 Source	8	Q3 Source
3	Q1 Drain	9	Q3 Drain
4	Q2 Gate	10	Q4 Gate
5	Q2 Source	11	Q4 Drain
6	Q2 Drain	12	Q4 Source

ABSOLUTE MAXIMUM RATINGS

V _{DSS}	Drain to Source Voltage	55V MAX
V _{DGDR}	Drain to Gate Voltage (R _{GS} = 1MΩ)	55V MAX
V _{GS}	Gate to Source Voltage (Continuous)	±20V MAX
I _D	Continuous Current	25A MAX
I _{DM}	Pulsed Current	49A MAX

T _J	Junction Temperature	+175°C MAX
T _{ST}	Storage Temperature	-55°C to +150°C
T _C	Case Operating Temperature Range	-55°C to +125°C
T _{LD}	Lead Temperature Range (10Seconds)	300°C MAX
R _{TH-JC}	Thermal Resistance (Junction to Case) @ 125°C	7.5°C/W
R _{TH-JC}	Thermal Resistance (Junction to Case) @ 25°C	5.5°C/W

ELECTRICAL SPECIFICATIONS

Parameter	Test Conditions 4	MSK 3013			Units
		Min.	Typ.	Max.	
Drain-Source Breakdown Voltage	V _{GS} = 0 ID = 0.25 mA	55	-	-	V
Drain-Source Leakage Current	V _D = 55V V _{GS} = 0V	-	-	25	μA
Gate-Source Leakage Current	V _{GS} = ±20V V _D = 0	-	-	±100	nA
Gate-Source Threshold Voltage	V _D = V _{GS} ID = 250 μA	2	-	4	V
Drain-Source on Resistance ②	V _{GS} = 10V ID = 25A	-	0.033	0.040	Ω
Drain-Source on Resistance ③	V _{GS} = 10V ID = 25A	-	-	0.022	Ω
Forward Transconductance ①	V _D = 25V ID = 25A	17	-	-	S
Total Gate Charge ①	ID = 25A	-	-	65	nC
Gate-Source Charge ①	V _D = 28V	-	-	12	nC
Gate-Drain Charge ①	V _{GS} = 10V	-	-	27	nC
Turn-On Delay Time ①	V _D = 28V	-	7.3	-	nS
Rise Time ①	ID = 25A	-	69	-	nS
Turn-Off Delay Time ①	R _G = 12Ω	-	47	-	nS
Fall Time ①	R _D = 1.1	-	60	-	nS
Input Capacitance ①	V _{GS} = 0V	-	1300	-	pF
Output Capacitance ①	V _D = 25V	-	410	-	pF
Reverse Transfer Capacitance ①	f = 1 MHz	-	150	-	pF
BODY DIODE					
Forward on Voltage ①	I _S = 25A V _{GS} = 0V	-	1.3	1.75	V
Reverse Recovery Time ①	I _S = 25A di/dt = 100A/μS	-	65	98	nS
Reverse Recovery Charge ①	I _S = 25A di/dt = 100A/μS	-	160	240	μC

NOTES:

- ① This parameter is guaranteed by design but need not be tested. Typical parameters are representative of actual device performance but are for reference only.
- ② Resistance as seen at package pins.
- ③ Resistance for die only; use for thermal calculations.
- ④ T_A = 25°C unless otherwise specified. Parameters apply to each transistor in the module.

APPLICATION NOTES

N-CHANNEL GATES

For driving the N-Channel gates, it is important to keep in mind that it is essentially like driving a capacitance to a sufficient voltage to get the channel fully on. Driving the gates to +15 volts with respect to their sources assures that the transistors are on. This will keep the dissipation down to a minimum level [$R_{DS(ON)}$ specified in the data sheet]. How quickly the gate gets turned ON and OFF will determine the dissipation of the transistor while it is transitioning from OFF to ON, and vice-versa. Turning the gate ON and OFF too slow will cause excessive dissipation, while turning it ON and OFF too fast will cause excessive switching noise in the system. It is important to have as low a driving impedance as practical for the size of the transistor. Many motor drive IC's have sufficient gate drive capability for the MSK 3013. If not, paralleled CMOS standard gates will usually be sufficient. A series resistor in the gate circuit slows it down, but also suppresses any ringing caused by stray inductances in the MOSFET circuit. The selection of the resistor is determined by how fast the MOSFET wants to be switched. See Figure 1 for circuit details.

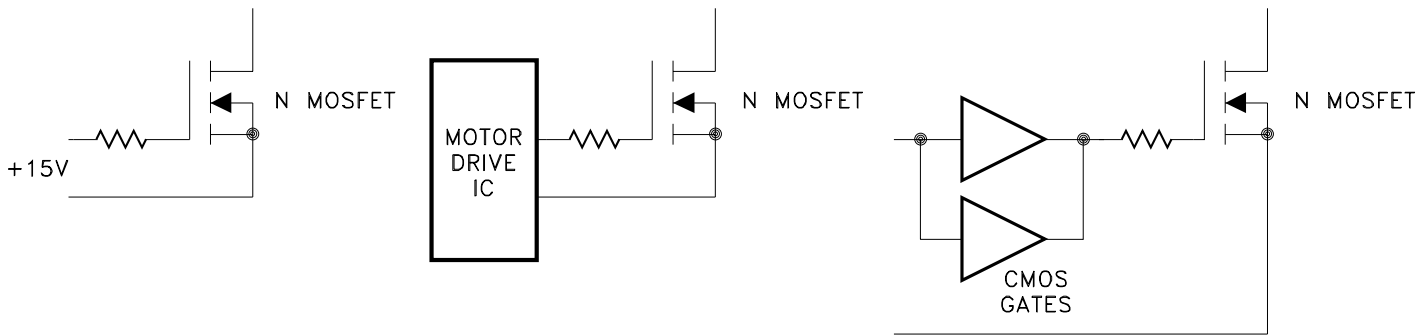

Figure 1

BRIDGE DRIVE CONSIDERATIONS

It is important that the logic used to turn ON and OFF the various transistors allow sufficient "dead time" between a high side transistor and its low side transistor to make sure that at no time are they both ON. When they are, this is called "shoot-through", and it places a momentary short across the power supply. This overly stresses the transistors and causes excessive noise as well. See Figure 3.

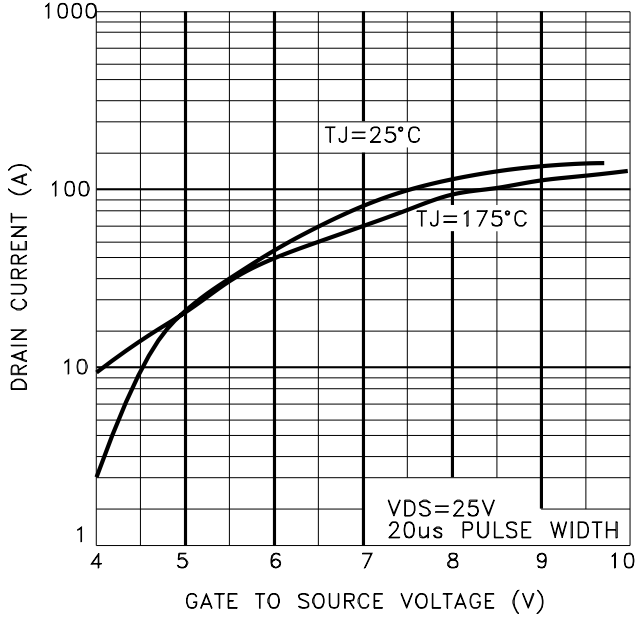

Figure 2

This deadtime should allow for the turn on and turn off time of the transistors, especially when slowing them down with gate resistors. This situation will be present when switching motor direction, or when sophisticated timing schemes are used for servo systems such as locked antiphase PWM'ing for high bandwidth operation.

TYPICAL PERFORMANCE CURVES

DRAIN CURRENT vs GATE TO SOURCE VOLTAGE



DRAIN CURRENT vs DRAIN TO SOURCE VOLTAGE

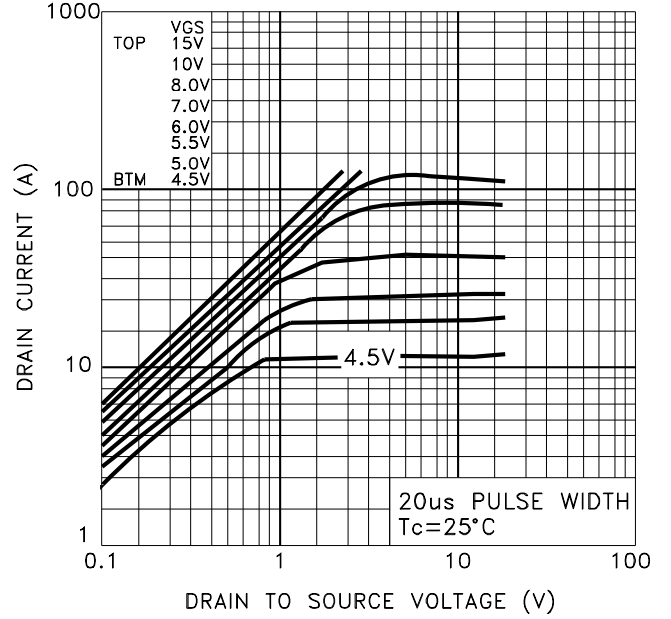

DRAIN TO SOURCE ON RESISTANCE vs JUNCTION TEMP.

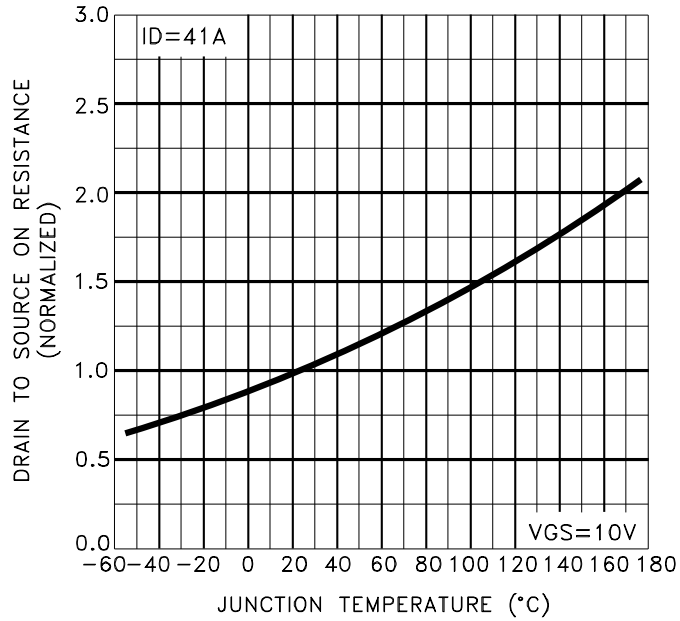

MECHANICAL SPECIFICATIONS

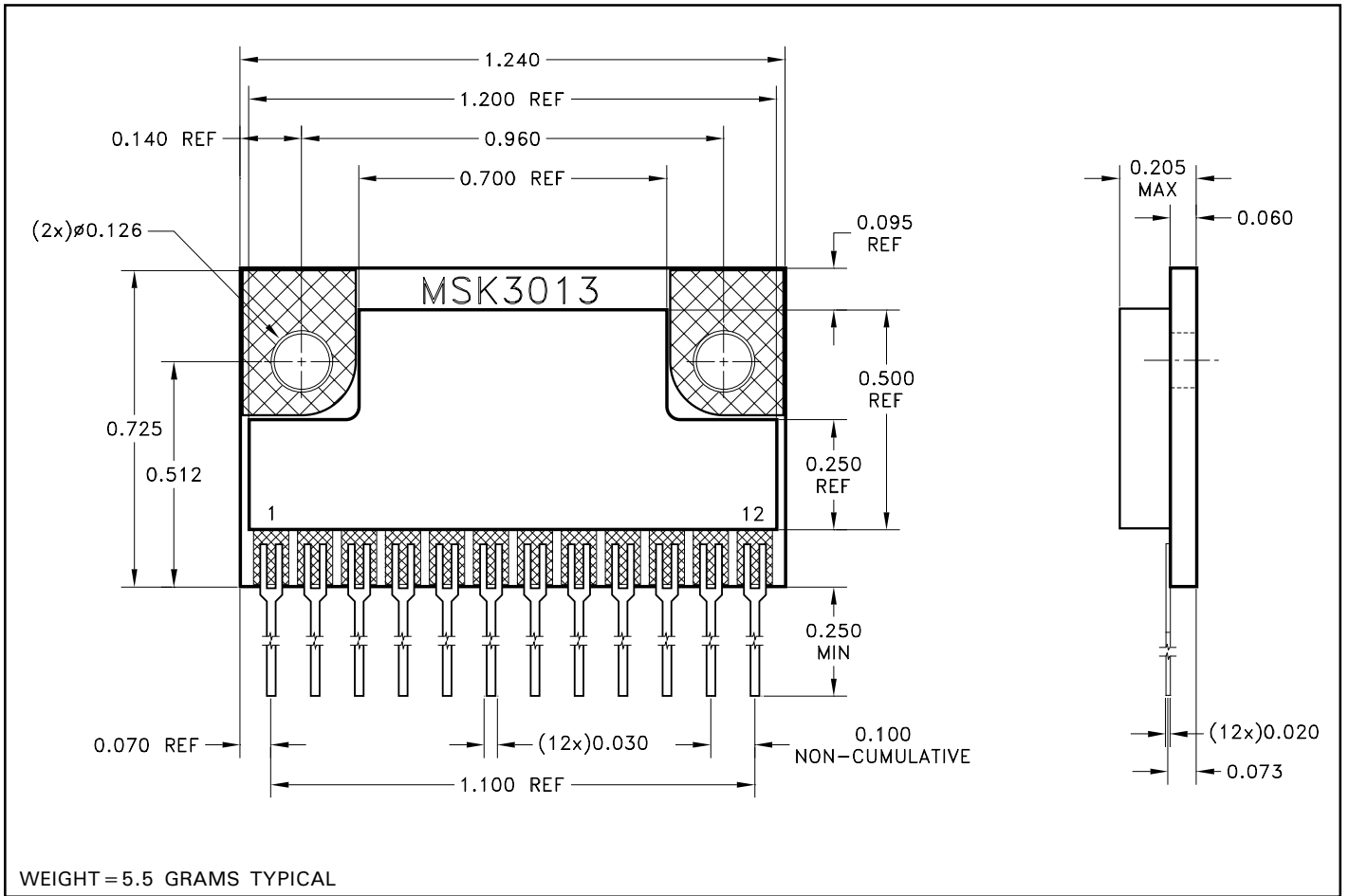

TORQUE SPECIFICATION 3 TO 5 IN/LBS. TEFLON SCREWS OR WASHERS ARE RECOMMENDED.
 ALL DIMENSIONS ARE ± 0.010 INCHES UNLESS OTHERWISE LABELED.

ORDERING INFORMATION

PART NUMBER	SCREENING LEVEL
MSK 3013	Industrial

M.S. Kennedy Corp.
 4707 Dey Road, Liverpool, New York 13088
 Phone (315) 701-6751
 FAX (315) 701-6752
 www.mskenddy.com

The information contained herein is believed to be accurate at the time of printing. MSK reserves the right to make changes to its products or specifications without notice, however, and assumes no liability for the use of its products.