



# DUAL HIGH POWER OP-AMP

# 2541

4707 Dey Road Liverpool, N.Y. 13088

(315) 701-6751

**FEATURES:**

- Available as SMD #5962-9083801 HX and 5962-9083803HX
- High Output Current - 10 Amps Peak
- Wide Power Supply Range -  $\pm 10V$  to  $\pm 40V$
- On Board Current Limit
- FET Input
- Isolated Case
- Second Source for OMA 2541SKB

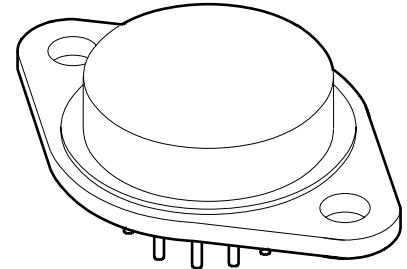

**DESCRIPTION:**

The MSK 2541 is a high power dual monolithic amplifier ideally suited for high power amplification and magnetic deflection applications. This amplifier is capable of operation at a supply voltage rating of 80 volts and can deliver guaranteed continuous output currents up to 5A per amplifier. The MSK 2541 has internal current limit circuitry to protect the amplifier and load from transients. The MSK 2541 is available in a hermetically sealed 8 pin TO3 package that is isolated from internal circuitry. This allows for convenient bolt down heat sinking when necessary.

**EQUIVALENT SCHEMATIC**

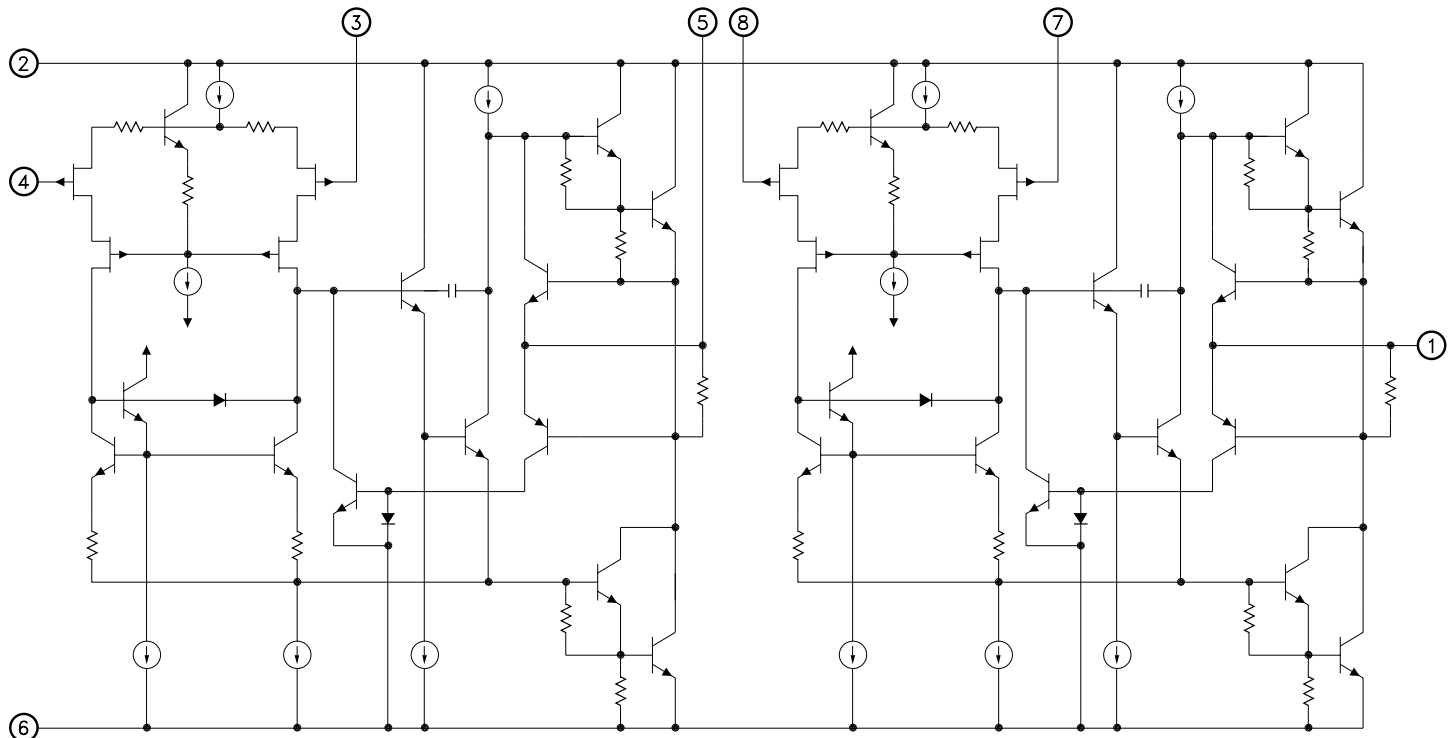

**TYPICAL APPLICATIONS**

- Servo Amplifier
- Motor Driver
- Audio Amplifier
- Programmable Power Supply
- Bridge Amplifier

**PIN-OUT INFORMATION**

- |                         |                         |
|-------------------------|-------------------------|
| 1 Output B              | 8 Inverting Input B     |
| 2 Positive Power Supply | 7 Non-Inverting Input B |
| 3 Non-Inverting Input A | 6 Negative Power Supply |
| 4 Inverting Input A     | 5 Output A              |

## ABSOLUTE MAXIMUM RATINGS <sup>⑩</sup>

$\pm V_{CC}$	Voltage Supply . . . . .	$\pm 40V$
$I_{OUT}$	Peak Output Current . . . . .	See S.O.A.
$V_{IN}$	Differential Input Voltage . . . . .	$\pm V_{CC}$
$V_{IN}$	Common Mode Input Voltage . . . . .	$\pm V_{CC}$
$T_C$	Case Operating Temperature Range	
	MSK 2541B/E . . . . .	$-55^\circ$ to $+125^\circ C$
	MSK 2541 . . . . .	$-40^\circ$ to $+85^\circ C$

$T_{ST}$	Storage Temperature Range . . . . .	$-65^\circ$ to $+150^\circ C$
$T_{LD}$	Lead Temperature Range . . . . .	$300^\circ C$ (10 Seconds)
$T_J$	Junction Temperature . . . . .	$150^\circ C$

## ELECTRICAL SPECIFICATIONS <sup>⑨</sup>

Parameter	Test Conditions	Group A Subgroup	MSK 2541B/E			MSK 2541 <sup>⑤</sup>			Units
			Min.	Typ.	Max.	Min.	Typ.	Max.	
<b>STATIC</b>									
Supply Voltage Range <sup>②</sup> <sup>④</sup>		-	$\pm 10$	$\pm 35$	$\pm 40$	$\pm 10$	$\pm 35$	$\pm 40$	V
Quiescent Current	Total - Both Amplifiers $V_{IN} = 0V$	1, 2, 3	-	$\pm 40$	$\pm 60$	-	$\pm 40$	$\pm 60$	mA
<b>INPUT</b>									
Input Offset Voltage	$V_{IN} = 0V$	1	-	$\pm 0.1$	$\pm 1.5$	-	$\pm 1.0$	$\pm 10$	mV
Input Offset Voltage Drift	$V_{IN} = 0V$	2, 3	-	$\pm 15$	$\pm 50$	-	$\pm 15$	-	$\mu V/^\circ C$
Input Bias Current <sup>④</sup>	$V_{CM} = 0V$ Either Input	1	-	$\pm 4$	$\pm 50$	-	$\pm 4$	$\pm 100$	pA
		2, 3	-	$\pm 10$	$\pm 150$	-	$\pm 10$	-	nA
Input Offset Current <sup>④</sup>	$V_{CM} = 0V$	1	-	2.0	30	-	2.0	30	pA
		2, 3	-	-	50	-	-	-	nA
Input Capacitance		-	-	5	-	-	5	-	pF
Input Impedance <sup>④</sup>	$F = DC$	-	-	$10^{12}$	-	-	$10^{12}$	-	W
Common Mode Rejection Ratio <sup>④</sup>	$F = DC$ $V_{CM} = \pm 22V$	-	95	113	-	90	113	-	dB
Power Supply Rejection Ratio <sup>④</sup>	$V_{CC} = \pm 10V$ to $\pm 40V$	-	-	90	-	-	90	-	dB
<b>OUTPUT</b>									
Output Voltage Swing	$R_L = 5.6\Omega$ $F \leq 10 KHZ$	4	$\pm 28$	$\pm 29$	-	$\pm 28$	$\pm 29$	-	V
	$R_L = 10\Omega$ $F = 10 KHZ$	5, 6	$\pm 30$	$\pm 31$	-	-	-	-	V
Output Current	$R_L = 5.6\Omega$ $F \leq 10 KHZ$	4	$\pm 5$	$\pm 8$	-	$\pm 5$	$\pm 8$	-	A
	$R_L = 10\Omega$ $F = 10 KHZ$	5, 6	$\pm 3.0$	-	-	-	-	-	A
Settling Time <sup>③</sup> <sup>④</sup>	0.1% 2V step	-	-	2	-	-	2	-	$\mu S$
Power Bandwidth	$R_L = 10\Omega$ $V_O = 20 V_{RMS}$	4	45	55	-	40	50	-	KHZ
<b>TRANSFER CHARACTERISTICS</b>									
Slew Rate	$V_{OUT} = \pm 10V$ $R_L = 10\Omega$	4	6	10	-	6	10	-	$V/\mu S$
Open Loop Voltage Gain <sup>④</sup>	$F = 10 Hz$ $R_L = 10 K\Omega$	4	95	100	-	90	100	-	dB
		5, 6	85	-	-	-	-	-	dB
<b>THERMAL RESISTANCE <sup>④</sup></b>									
$\theta_{JC}$ (Junction to Case)	One Amplifier, DC Output	-	-	1.4	1.9	-	1.9	2.2	$^\circ C/W$
$\theta_{JC}$	One Amplifier, AC Output $F > 60 Hz$	-	-	1.25	1.5	-	1.7	1.8	$^\circ C/W$
$\theta_{JC}$	Both Amplifiers, DC Output	-	-	0.9	1.2	-	1.2	1.5	$^\circ C/W$
$\theta_{JC}$	Both Amplifiers, AC Output $F > 60 Hz$	-	-	0.8	1.0	-	1.1	1.3	$^\circ C/W$
$\theta_{JA}$ (Junction to Ambient)	No Heat Sink	-	-	30	-	-	30	-	$^\circ C/W$

### NOTES:

- ① Unless otherwise specified:  $\pm V_{CC} = \pm 34 V_{DC}$ , all specs are per amplifier.
- ② Electrical specifications are derated for power supply voltages other than  $\pm 34 V_{DC}$ .
- ③  $AV = -1$ , measured in false summing junction circuit.
- ④ Devices shall be capable of meeting the parameter, but need not be tested. Typical parameters are for reference only.
- ⑤ Industrial and E grade devices shall be tested to subgroups 1 and 4 unless otherwise specified.
- ⑥ Military grade devices ('B' suffix) shall be 100% tested to subgroups 1, 2, 3 and 4.
- ⑦ Subgroup 5 and 6 testing available upon request.
- ⑧ Subgroup 1, 4  $T_A = T_C = +25^\circ C$   
Subgroup 2, 5  $T_A = T_C = +125^\circ C$   
Subgroup 3, 6  $T_A = T_C = -55^\circ C$
- ⑨ Reference DSCC SMD 5962-9083801 and 5962-9083803 for electrical specifications for devices purchased as such.
- ⑩ Continuous operation at or above absolute maximum ratings may adversely effect the device performance and/or life cycle.

## APPLICATION NOTES

### HEAT SINKING

To select the correct heat sink for your application, refer to the thermal model and governing equation below.

Thermal Model:

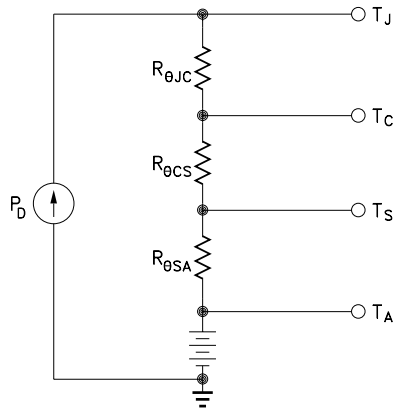

Governing Equation:

$$T_J = P_D \times (R_{\theta JC} + R_{\theta CS} + R_{\theta SA}) + T_A$$

Where

- $T_J$  = Junction Temperature
- $P_D$  = Total Power Dissipation
- $R_{\theta JC}$  = Junction to Case Thermal Resistance
- $R_{\theta CS}$  = Case to Heat Sink Thermal Resistance
- $R_{\theta SA}$  = Heat Sink to Ambient Thermal Resistance
- $T_C$  = Case Temperature
- $T_A$  = Ambient Temperature
- $T_S$  = Sink Temperature

Example:

In our example the amplifier application requires each output to drive a 20 volt peak sine wave across a 10 ohm load for 2 amps of output current. For a worst case analysis we will treat the 2 amps peak output current as a D.C. output current. The power supplies are  $\pm 35$  VDC.

1.) Find Power Dissipation

$$\begin{aligned} P_D &= [(quiescent\ current) \times (+V_{CC} - (-V_{CC}))] + [(V_{CC} - V_o) \times I_{out}] \\ &= (30\ mA) \times (70V) + (15V) \times (2A) + (15V) \times (2A) \\ &= 2.1W + 60W \\ &= 62.1W \end{aligned}$$

2.) For conservative design, set  $T_J = +150^\circ C$

3.) For this example, worst case  $T_A = +25^\circ C$

4.)  $R_{\theta JC} = 1.2^\circ C/W$  typically

5.)  $R_{\theta CS} = 0.15^\circ C/W$  for most thermal greases

6.) Rearrange governing equation to solve for  $R_{\theta SA}$

$$\begin{aligned} R_{\theta SA} &= (T_J - T_A) / P_D - (R_{\theta JC}) - (R_{\theta CS}) \\ &= (150^\circ C - 25^\circ C) / (62.1W) - (1.2^\circ C/W) - (0.15^\circ C/W) \\ &= \cong 0.66^\circ C/W \end{aligned}$$

The heat sink in this example must have a thermal resistance of no more than  $0.66^\circ C/W$  to maintain a junction temperature of no more than  $+150^\circ C$ . Since this value of thermal resistance may be difficult to find, other measures may have to be taken to decrease the overall power dissipation. Refer to the "Heat Sinking Options" application note offered by MSK.

### POWER SUPPLY CONNECTIONS

The MSK 2541 maximum supply voltage is specified as  $\pm 40V$ . However, single sided or unbalanced power supply operation is permissible as long as the total power supply voltage does not exceed 80V. Caution should be exercised when routing high current printed circuit paths. Generally, these paths should not be placed near low level, high impedance input circuitry to avoid oscillations.

During prototype evaluation, power supply current limiting is strongly advised to avoid damaging the device. See the application note entitled "Current Limit" for an explanation of the limitations of the MSK 2541 on board current limit.

### POWER SUPPLY BYPASSING

Both the negative and the positive power supplies must be effectively decoupled with a high and low frequency bypass circuit to avoid power supply induced oscillation. An effective decoupling scheme consists of a 0.1 microfarad ceramic capacitor in parallel with a 4.7 microfarad tantalum capacitor from each power supply pin to ground. It is also a good practice with very high power op-amps, such as the MSK 2541, to place a 30-50 microfarad non-electrolytic capacitor with a low effective series resistance in parallel with the other two power supply decoupling capacitors. This capacitor will eliminate any peak output voltage clipping which may occur due to poor power supply load regulation. All power supply decoupling capacitors should be placed as close to the package power supply pins as possible (pins 3 and 6).

### CURRENT LIMIT

The internal current limit should not be used as a short circuit protection scheme. When the output is directly shorted to ground, the power supply voltage is applied across the output transistor that is conducting. If the power supplies were set to  $\pm 40V$  and the output was shorted to ground, the transistor that is conducting current would see 40V from its emitter to its collector. Referring to the safe operating area curve shows when  $[V_{CC} - V_{OUT}] = 40V$ , the maximum safe output current ( $I_o$ ) at  $T_C = 25^\circ C$  is 1.5A. In this case the amplifier would not be protected by the internal current limit and would probably be damaged. The internal current limit is provided as a protection against unintentional load conditions which may require larger amounts of load current than the amplifier is rated for.

### SAFE OPERATING AREA

The safe operating area curve is a graphical representation of the power handling capability of the amplifier under various conditions. The wire bond current carrying capability, transistor junction temperature and secondary breakdown limitations are all incorporated into the safe operating area curves. All applications should be checked against the S.O.A. curves to ensure high M.T.T.F.

# TYPICAL PERFORMANCE CURVES

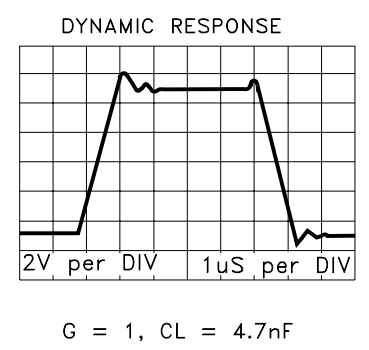
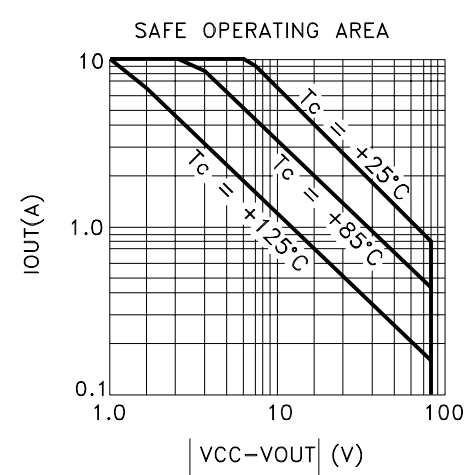
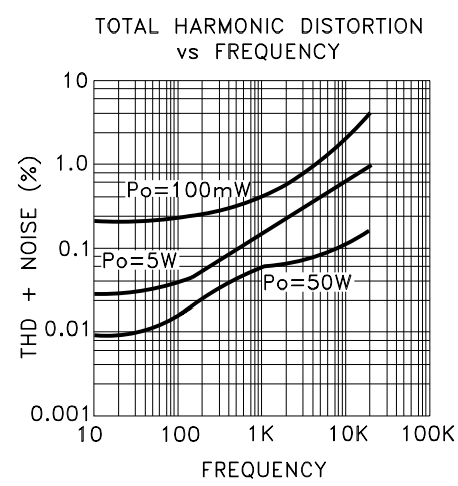
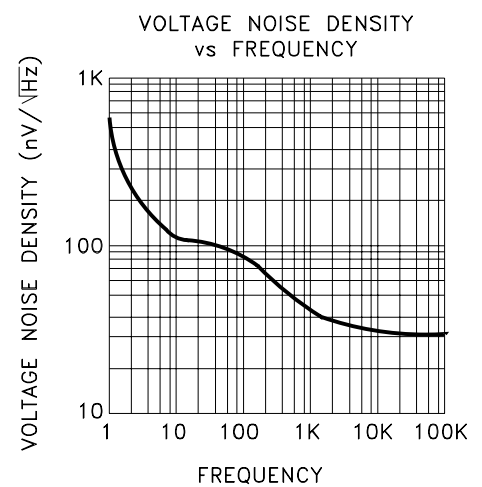
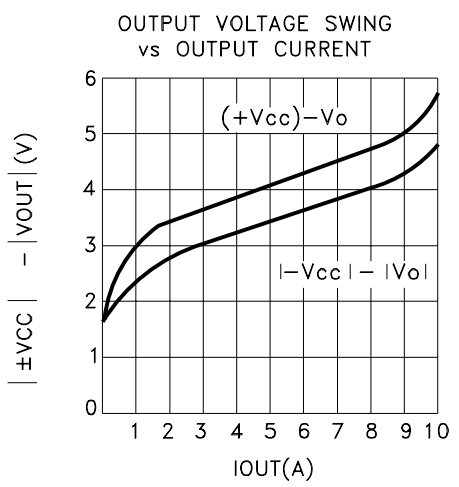
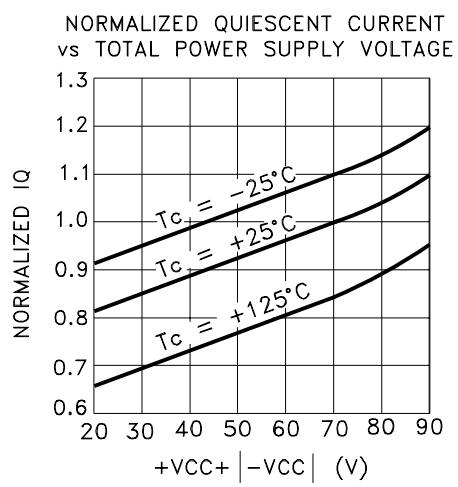
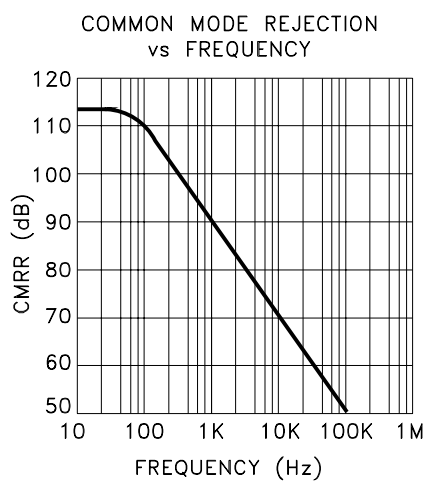
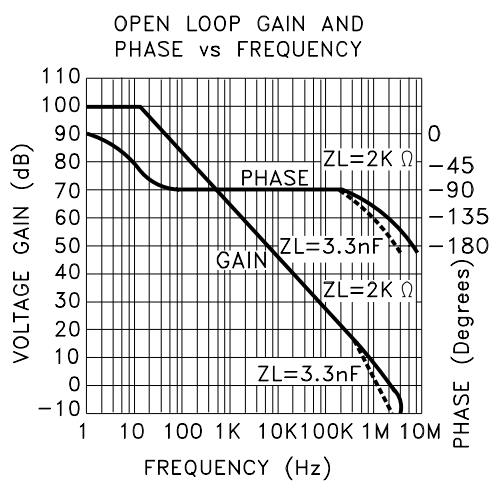
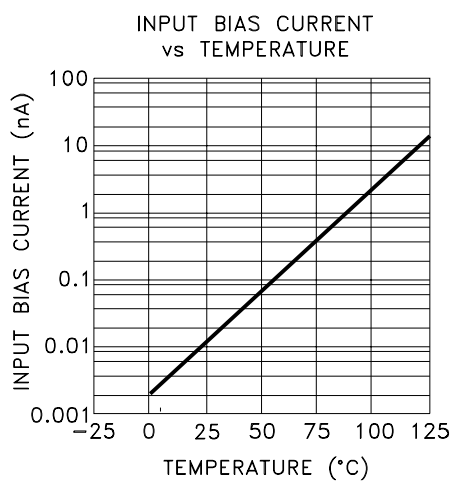

# APPLICATION CIRCUITS

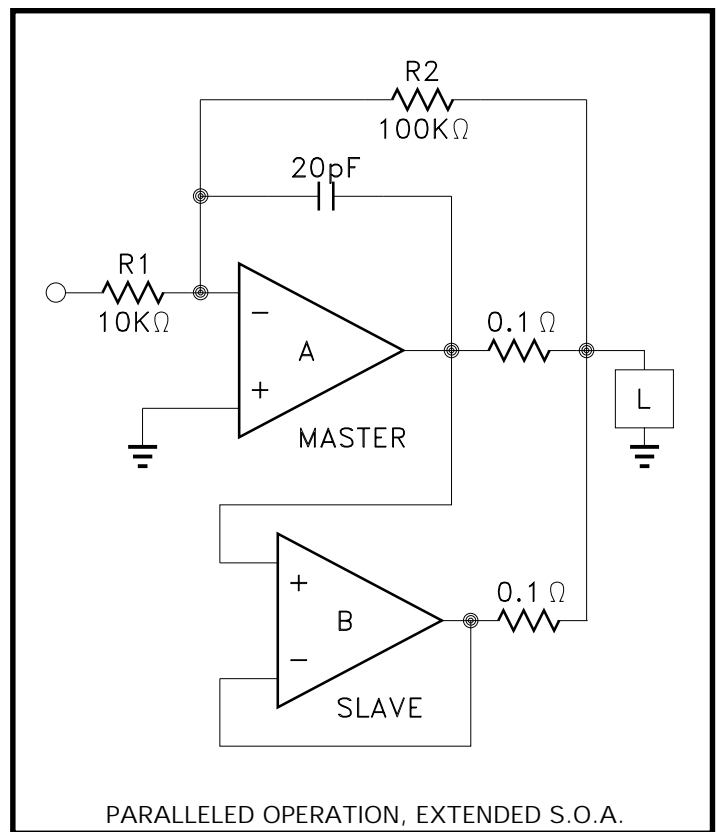
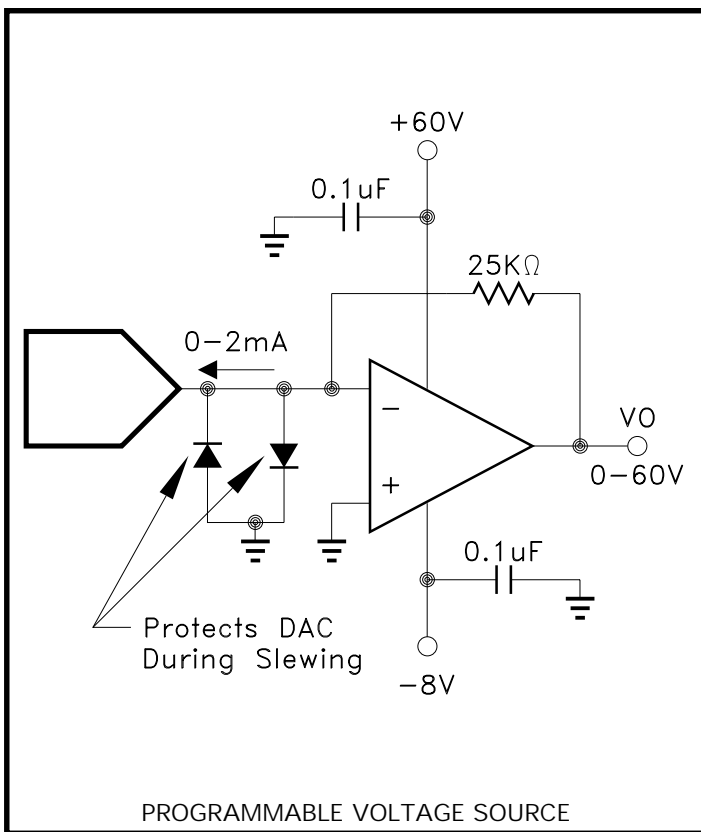
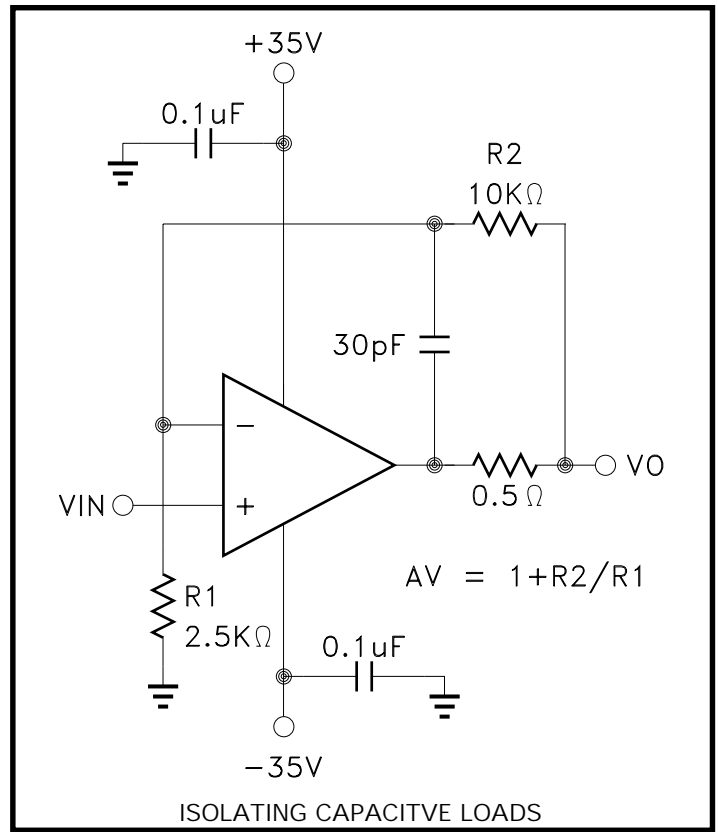
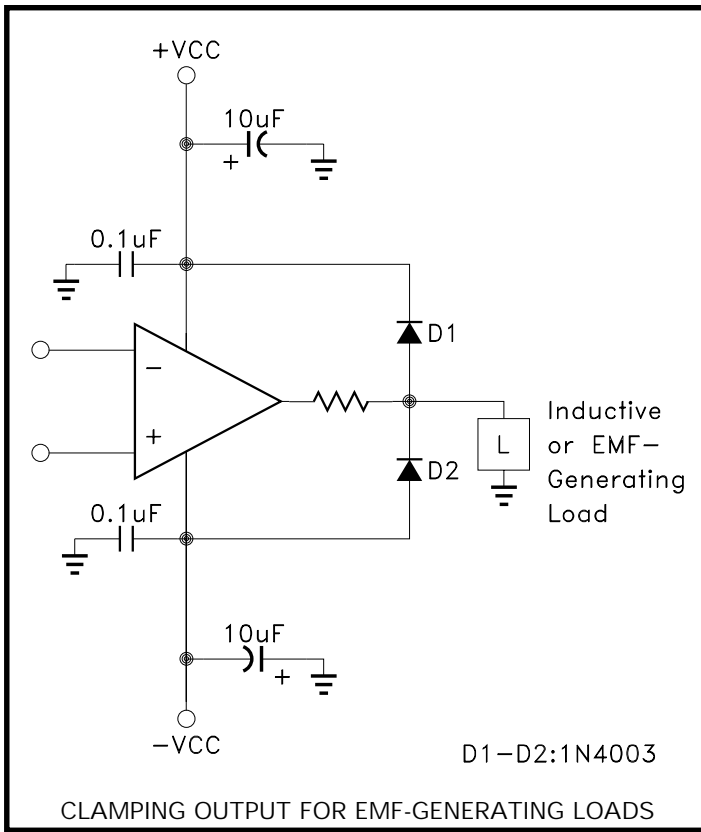

## MECHANICAL SPECIFICATIONS

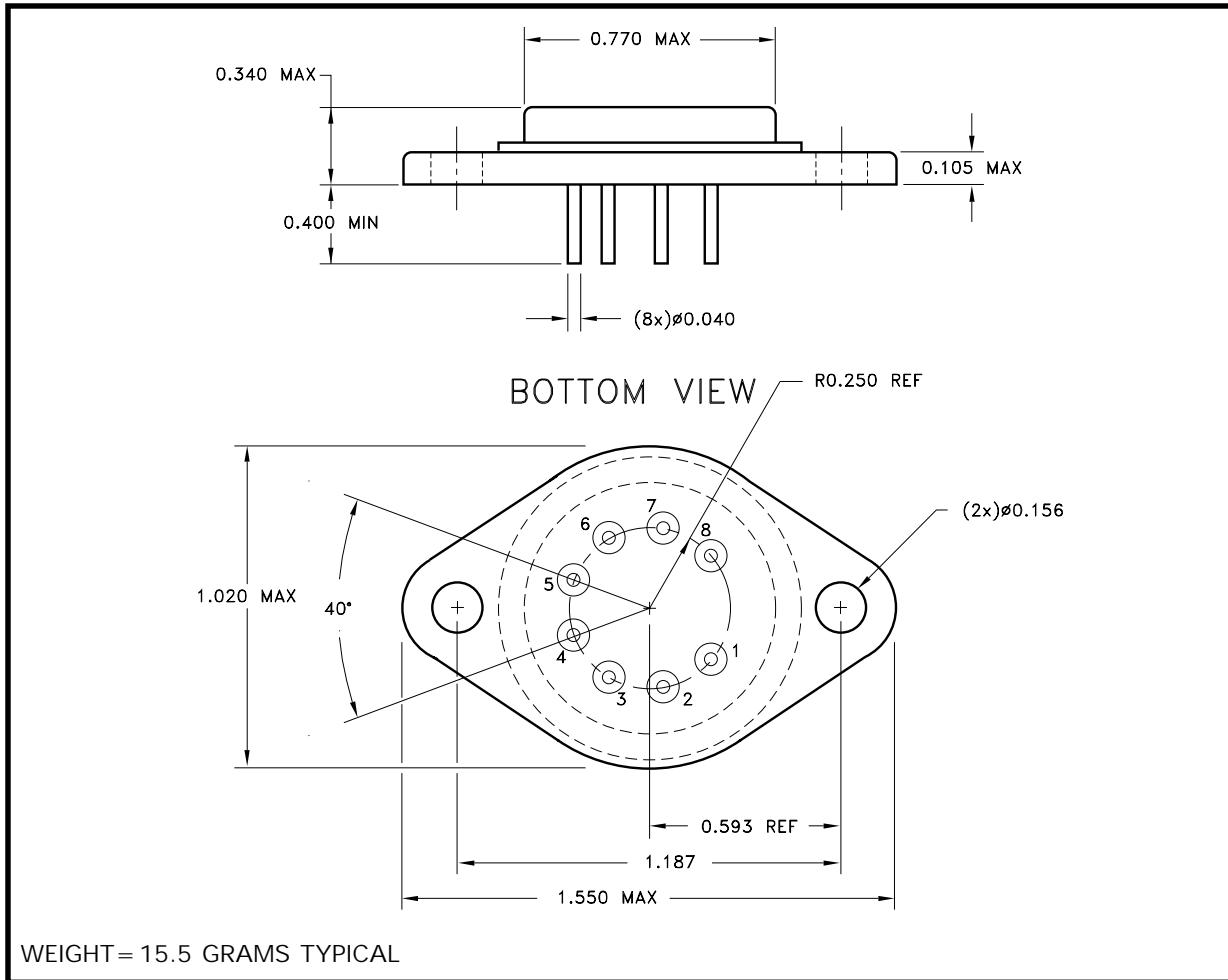

ALL DIMENSIONS ARE  $\pm 0.010$  INCHES UNLESS OTHERWISE SPECIFIED.

## ORDERING INFORMATION

Part Number	Screening Level
MSK2541	Industrial
MSK2541E	Extended Reliability
MSK2541B	MIL-PRF-38534, Class H
5962-9083801HX	DSCC-SMD
5962-9083803HX	DSCC-SMD

M.S. Kennedy Corp.

4707 Dey Road, Liverpool, New York 13088

Phone (315) 701-6751

Fax (315) 701-6752

www.mskennedy.com

The information contained herein is believed to be accurate at the time of printing. MSK reserves the right to make changes to its products or specifications without notice, however and assumes no liability for the use of its products. Please visit our website for the most recent revision of this datasheet.