



ULTRA HIGH SPEED/VOLTAGE VIDEO AMPLIFIER

1922

SERIES

M.S.KENNEDY CORP.

4707 Dey Road Liverpool, N.Y. 13088

(315) 701-6751

FEATURES:

- Ultra High Performance Complete Amplifier System
- 50Vpp Output Signal Into 10pF
- Ultra Fast Transition Times: 1.5nS @ 50Vpp
- User Adjustable Contrast and Brightness
- TTL Compatible Blanking
- On Board DC Reference Output
- Customized Versions Readily Available

MIL-PRF-38534 CERTIFIED

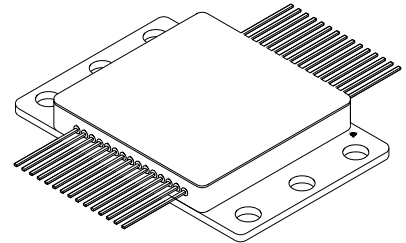

DESCRIPTION:

The MSK 1922 High Speed, High Voltage Video Amplifier is designed to directly drive the cathode of today's high performance CRT's. The MSK 1922 has user adjustable contrast and brightness levels and also comes with a blanking function. The MSK 1922 can be directly connected to many video sources including RS170, RS343 and high speed video D/A converters. The MSK 1922 has an internal resistor-inductor designed for optimum bandwidth. The MSK 1922 is packaged in a hermetic 30 pin power flatpack that can be directly connected to a heat sink using standard 4-40 screws.

EQUIVALENT SCHEMATIC

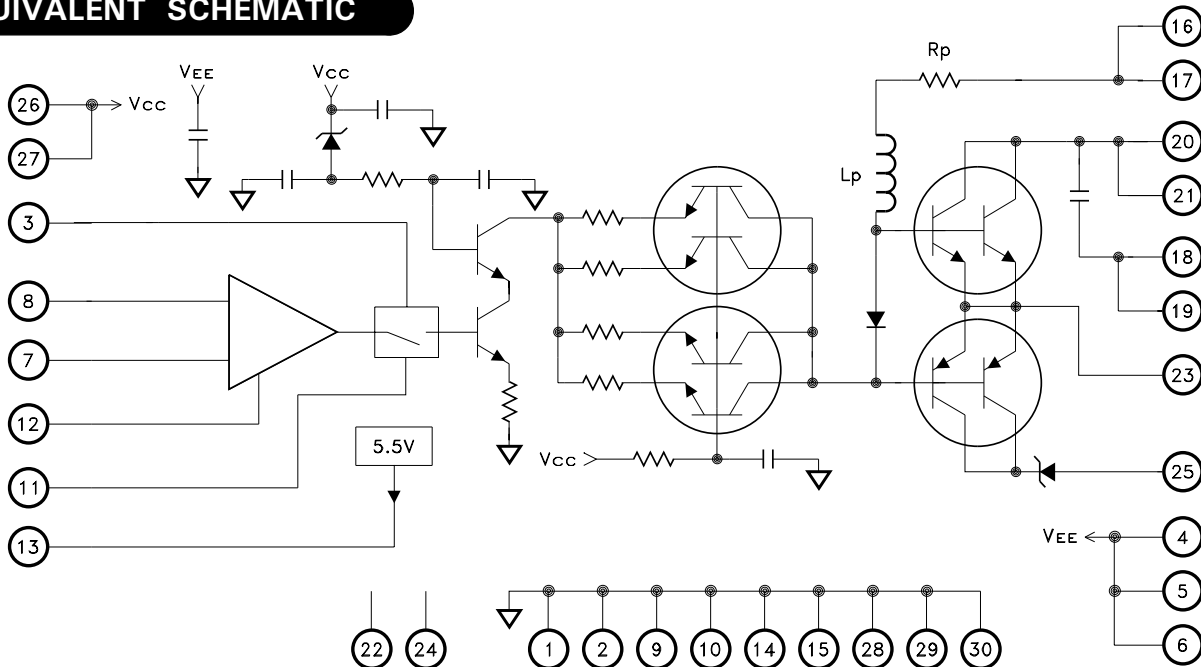

TYPICAL APPLICATIONS

- Helmet Mounted Displays
- High Resolution RGB Displays
- High Resolution Monochrome Displays
- Automatic Test Equipment
- Medical Monitors
- CAE/CAD Station Monitors

PIN-OUT INFORMATION

1	GND	11	VGAIN	21	VHV
2	GND	12	VOFF	22	NC
3	Blank	13	VREF	23	Output
4	VEE	14	GND	24	NC
5	VEE	15	GND	25	Cath. RTN/GND
6	VEE	16	VHV RES	26	VCC
7	-Input	17	VHV RES	27	VCC
8	+ Input	18	GND	28	GND
9	GND	19	GND	29	GND
10	GND	20	VHV	30	GND

ABSOLUTE MAXIMUM RATINGS

+V _{HV}	High Voltage Supply	+75V	V _{BLANK}	Blank Input Voltage	-0.6 to +6V
V _{CC}	Positive Supply Voltage	+17V	I _{REF}	Reference Output Current	5mA
V _{EE}	Negative Supply Voltage	-12V	T _{ST}	Storage Temperature Range	-40°C to +150°C
V _{IN}	Differential Input Voltage	±2V	T _{LD}	Lead Temperature Range	300°C (10 Seconds)
V _{IC}	Common Mode Input Voltage	±2V	T _J	Junction Temperature	175°C
V _{GAIN}	Gain Adjust Input Voltage	-0.6 to +6V	I _{RP}	Current Through R _p	290mA
V _{OFF}	Offset Adjust Input Voltage	-0.6 to +6V	T _C	Case Operating Temperature	-40°C to +125°C

ELECTRICAL SPECIFICATIONS

Parameter	Test Conditions ①	MSK1922			Units
		Min.	Typ.	Max.	
STATIC					
Quiescent Current ④	V _{CM} = 0V @ +15V	-	75	100	mA
	V _{CM} = 0V @ -10.5V	-	-75	-100	mA
High Voltage Supply ②		30	70	75	V
Thermal Resistance to Case ②	Q _{OUT} and Q _{CAS}	-	24	26	°C/W
INPUT					
Input Bias Current ②	V _{CM} = 0V	-	±1	±50	μA
Blank Input Current ②	V _{BLANK} = 0.4V	-	500	600	μA
	V _{BLANK} = 2.4V	-	300	400	μA
Offset Adjust Input Current ②	V _{OFF} = 1V	-	2	10	μA
Gain Adjust Input Current ②	V _{GAIN} = 5V	-	2	10	μA
Blank Input Pulse Width ②	Normal Operation	30	-	-	nS
Common Mode Rejection Ratio ②	V _{CM} = ±0.5V F = 10Hz	-	40	-	dB
Input Impedance ②	Either Input F = DC	10K	20K	-	Ω
Input Capacitance ②	Either Input	-	2	-	pF
Blank Mode Input Rejection ΔV ② ③	V _{BLANK} = 2.4V V _{IN} = 0.3V ΔV = V _{HV} - V _{OUT}	-	-	±2xR _p	mV
Gain Adjust Rejection ΔV ② ③	ΔV _{GAIN} = 5V	-	-	±10xR _p	mV
Power Supply Rejection Ratio ②	+V _{CC} and -V _{EE} = Nom ±5%	25	30	-	dB
Internal R _p ② ③		140	150	160	Ω
OUTPUT					
Reference Output Voltage ④	I _{OUT} < 2mA	5.2	5.5	5.8	V
ΔV Blank Mode ③	ΔV = V _{HV} - V _{OUT} V _{OFF} = 1V V _{BLANK} = 2.4V V _{GAIN} = 5V	-3xR _p	R _p	3xR _p	mV
ΔV Min Offset ③	ΔV = V _{HV} - V _{OUT} V _{OFF} = 0V V _{GAIN} = 3V	0	2	6	V
ΔV Max Offset ③	ΔV = V _{HV} - V _{OUT} V _{OFF} = 5V	11	16	21	V
Voltage Gain ④	V _{IN} = 0.6V F = 10KHz V _{GAIN} = 4V Both Inputs	40	54	64	V/V
Output Voltage High ④	V _{GAIN} = 4V F = 10KHz	65	68	-	V
Output Voltage Low ④	V _{GAIN} = 4V F = 10KHz	-	10	20	V
Transition Times ②	V _{IN} = 0.6V TR = TF < 0.2nS (input)	-	1.5	-	nS
Linearity Error ②	V _{GAIN} = 4V V _{OFF} = 1V V _{CM} = 0.5V	-	-	±2	%GS
Gain Linearity ②	V _{OFF} = 1V V _{IN} = 2.0V V _{CM} = 0.5V	-	-	±2	%
Thermal Distortion ②		-	-	±2	%GS

NOTES:

- ① +V_{CC} = +15V, -V_{EE} = -10.5V, V_{BLANK} = V_{GAIN} = V_{OFF} = ±V_{IN} = 0V, C_L = 10pF, T_C = 25°C unless otherwise specified.
- ② This parameter is guaranteed by design but need not be tested. Typical parameters are representative of actual device performance but are for reference only.
- ③ ΔV is defined as the difference between +V_{HV} and the output.
- ④ Parameter is 100% tested on production devices.

APPLICATION NOTES

POWER SUPPLIES

The input stage of the MSK 1922 requires power supplies of +15V and -10.5V for optimum operation. The negative power supply can be increased to -12V if -10.5V is not available, but additional power dissipation will cause the internal temperature to rise. Both low voltage power supplies should be effectively decoupled with tantalum capacitors (at least 4.7 μ F) connected as close to the amplifier's pins as possible. The MSK 1922 has internal 0.01 μ F capacitors that also improve high frequency performance. In any case, it is also recommended to put 0.1 μ F decoupling capacitors on the +15V and -10.5V supplies as well.

The high voltage power supply (+VHV) is connected to the amplifier's output stage and must be kept as stable as possible. The internal Rp is connected to +VHV and as such, the amplifier's DC output is directly related to the high voltage value. The +VHV pins of the hybrid should be decoupled to ground with as large a capacitor as possible to improve output stability.

SUPPLY SEQUENCING

The power supply sequence is VHV, VCC, VEE followed by the other DC control inputs. If power supply sequencing is not possible, the time difference between each supply should be less than five milliseconds. If the DC control signals are being generated from a low impedance source other than the VREF output, reverse biased diodes should be connected from each input (VGAIN, VOFF) to the VCC pin. This will protect the inputs until VCC is turned on.

VIDEO OUTPUT

When power is first applied and VIN = VGAIN = VOFF = 0V, the output will be practically at the +VHV rail voltage. The output voltage is a function of the value of Rp and also the VGAIN and VOFF DC inputs. The maximum output voltage swing for the MSK 1922 is determined by (Rp). The bandwidth of the amplifier largely depends on both Rp and Lp.

Hybrid pins 16 and 17 are directly connected to Rp. Additional external resistance can be added to reduce power dissipation, but slower transition times will result. If an additional resistor is used, it must be low capacitance and the layout should minimize capacitive coupling to ground (ie: no ground plane under Rp).

The MSK 1922 is specified with no external Lp which yields about 10% overshoot. Additional peaking can be obtained by using a high self-resonant frequency inductor in series with pins 16 & 17. Since this value of inductance can be very dependent on circuit layout, it is best to determine its value by experimentation. A good starting point is typically 0.0047 μ H.

If external resistors or inductors are not used, be sure to connect high frequency bypass capacitors directly from pins 16 and 17 to ground.

VIDEO INPUTS

The video input signals should be kept below $\pm 2V_{MAX}$ total, including both common mode offset and signal levels. The input structure of the MSK 1922 was designed for $\pm 0.714V_{pp}$ RS343 signals. If either input is not used it should be connected directly to the analog ground or through a 25 Ω resistor to ground if input offset currents are to be minimized.

OUTPUT PROTECTION

The output pin of the MSK 1922 should be protected from transients by connecting reversed biased ultra-low capacitance diodes from the output pin to both +VHV and ground. The output can also be protected from arc voltages by inserting a small value (25-50 Ω) resistor in series with the amplifier. This resistor will reduce system bandwidth along with the load capacitance, but a series inductor can reduce the problem substantially.

VGAIN CONTROL INPUT

The VGAIN control (contrast) input is designed to allow the user to vary the video gain. By simply applying a DC voltage from 0V to VREF, the video gain can be linearly adjusted from 0 to 73V/V. The VGAIN input should be connected to the VREF pin through a 5K Ω pot to ground. For convenient stable gain adjustment, a 0.1 μ F bypass capacitor should be connected near the VGAIN input pin to prevent output instability due to noisy sources. Digital gain control can be accomplished by connecting a D/A converter to the VGAIN pin. However, some temperature tracking performance may be lost when using an external DC voltage source other than VREF for gain adjustment. The bandwidth of the VGAIN input is approximately 1MHz.

The overall video output of the MSK 1922 can be characterized using the following expression:

$$V_{pp} = V_{HV} - V_{OUT}$$

$$V_{HV} - V_{OUT} = (V_{IN})(V_{GAIN})(R_p)(0.09)$$

(or)

$$\text{Voltage Gain} = V_{OUT}/V_{IN} = (V_{GAIN})(R_p)(0.09)$$

Here is a sample calculation for the MSK 1922:
Given information

- VIN = 0.7V
- VGAIN = 1VDC
- Rp = 150 Ω (internal)
- VHV = 70VDC

$$V_{HV} - V_{OUT} = (0.7V)(1V)(150\Omega)(0.09)$$
$$V_{HV} - V_{OUT} = 9.5V \text{ Nominal}$$

The expected video output would swing from approximately +70V to +60.5 V assuming that VOFF = 0V. This calculation should be used as a nominal result because the overall gain may vary as much as $\pm 20\%$ due to internal high speed device variations. Changing ambient conditions can also effect the video gain of the amplifier by as much as 150 PPM/ $^{\circ}$ C. It is wise to connect all video amplifiers to a common heat sink to maximize thermal tracking when multiple amplifiers are used in applications such as RGB systems. Additionally, only one of the VREF outputs should be shared by all three amplifiers. This voltage should be buffered with a suitable low drift op-amp for best tracking performance.

APPLICATION NOTES CON'T

VOFF CONTROL INPUT

The brightness (output offset) can be linearly adjusted by applying a 0 to VREF DC voltage to the VOFF input pin. The output quiescent voltage range is from approximately $(5\mu A)(R_p)$ to $(100mA)(R_p)$ from +VHV. This control voltage is normally generated by connecting the VOFF control pin to a 5K potentiometer between VREF and ground. The VOFF input pin should be bypassed with a $0.1\mu F$ capacitor to ground placed as close as possible to the hybrid. This DC voltage can be any stable system source. The bandwidth of the VOFF pin is approximately 1MHz.

Keep hybrid power dissipation in mind when adjusting the output quiescent voltage. Practically all of the voltage is seen across R_p ! This power must be taken into account when high R_p currents are used. If the quiescent level is set too close to +VHV, the power dissipation will be minimal but the rise time will suffer slightly. If the quiescent level is set too far from +VHV, the power dissipation will increase dramatically and the output fall time will be limited. The output black level is obviously dependent on system requirements but a little experimentation will strike the optimum balance between power dissipation and bandwidth. The gain adjust alone can set the AC current to 333mA (ie: $333mA_{pp} = 50V_{pp}/150\Omega$). Typically, most applications use about 5V from +VHV for a black level.

BLANK INPUT

The video input can be electrically disconnected from the amplifier by applying a TTL high input to the blank pin. When this occurs, the output will be set to approximately +VHV. The VGAIN and VOFF control pins have little or no effect on the output when it is in blank mode.

When the TTL compatible blank input is not used, the pin must be connected to ground to enable the amplifier. The blank input will float high when left unconnected which will disable the video.

VREF OUTPUT

The MSK 1922 has an on board buffered DC zener reference output. The VREF output is nominally 5.5V DC and has full temperature test limits of 5.2V to 5.8V DC. This output is provided for gain and offset adjustment and can source up to 4mA of current.

THERMAL MANAGEMENT

The MSK 1922 package has mounting holes that allow the user to connect the amplifier to a heat sink or chassis. Since the package is electrically isolated from the internal circuitry, mounting insulators are not required or desired for best thermal performance.

The power dissipation of the amplifier depends mainly on the load requirements, bandwidth, pixel size, black level and the value of R_p .

RESOLUTION TABLE FOR TYPICAL CRT'S

Display Resolution	Maximum Pixel Time	Minimum Pixel Clock Frequency	Required Rise Time at CRT Cathode	Required System Bandwidth (F-3dB)
320 x 200	182nS	5MHz	60nS	6MHz
640 x 350	52nS	19MHz	17nS	20MHz
640 x 480	38nS	26MHz	12.5nS	28MHz
800 x 560	26nS	38MHz	8.6nS	41MHz
1024 x 900	12.6nS	80MHz	4.2nS	84MHz
1024 x 1024	11nS	90MHz	3.7nS	95MHz
1280 x 1024	8.9nS	112MHz	2.9nS	120MHz
1664 x 1200	5.8nS	170MHz	1.9nS	180MHz
2048 x 2048	2.8nS	360MHz	1nS	380MHz
4096 x 3300	860pS	1.2GHz	280pS	1.23GHz

All data assumes retrace time equal to 30% of frame time and a 60Hz refresh rate.

TYPICAL CONNECTION CIRCUIT

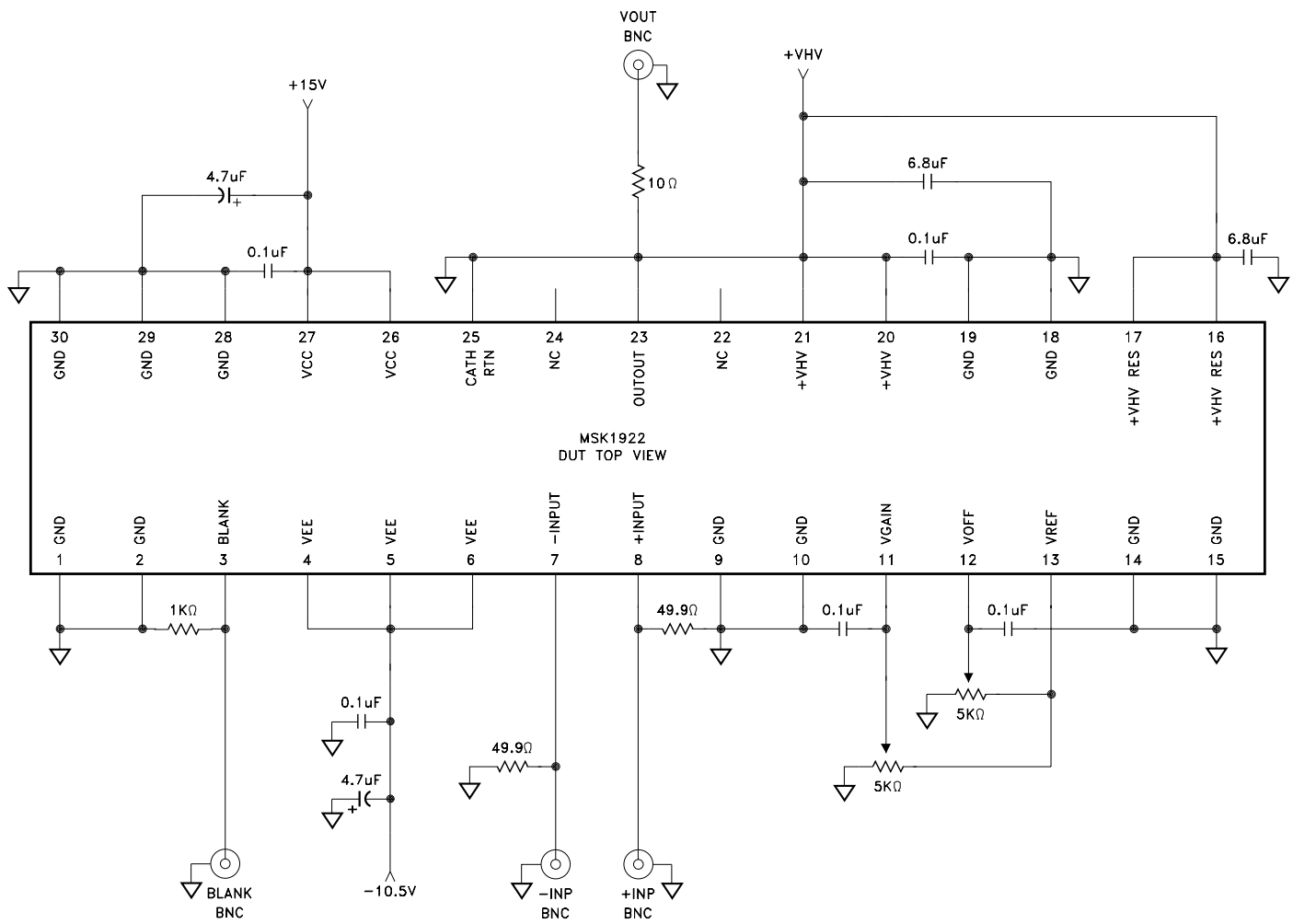

The connection circuit shown above is for the MSK 1922 evaluation board.

For additional applications information, please contact the factory. Evaluation amplifiers with test boards are readily available from MSK.

NOTES: _____

MECHANICAL SPECIFICATIONS

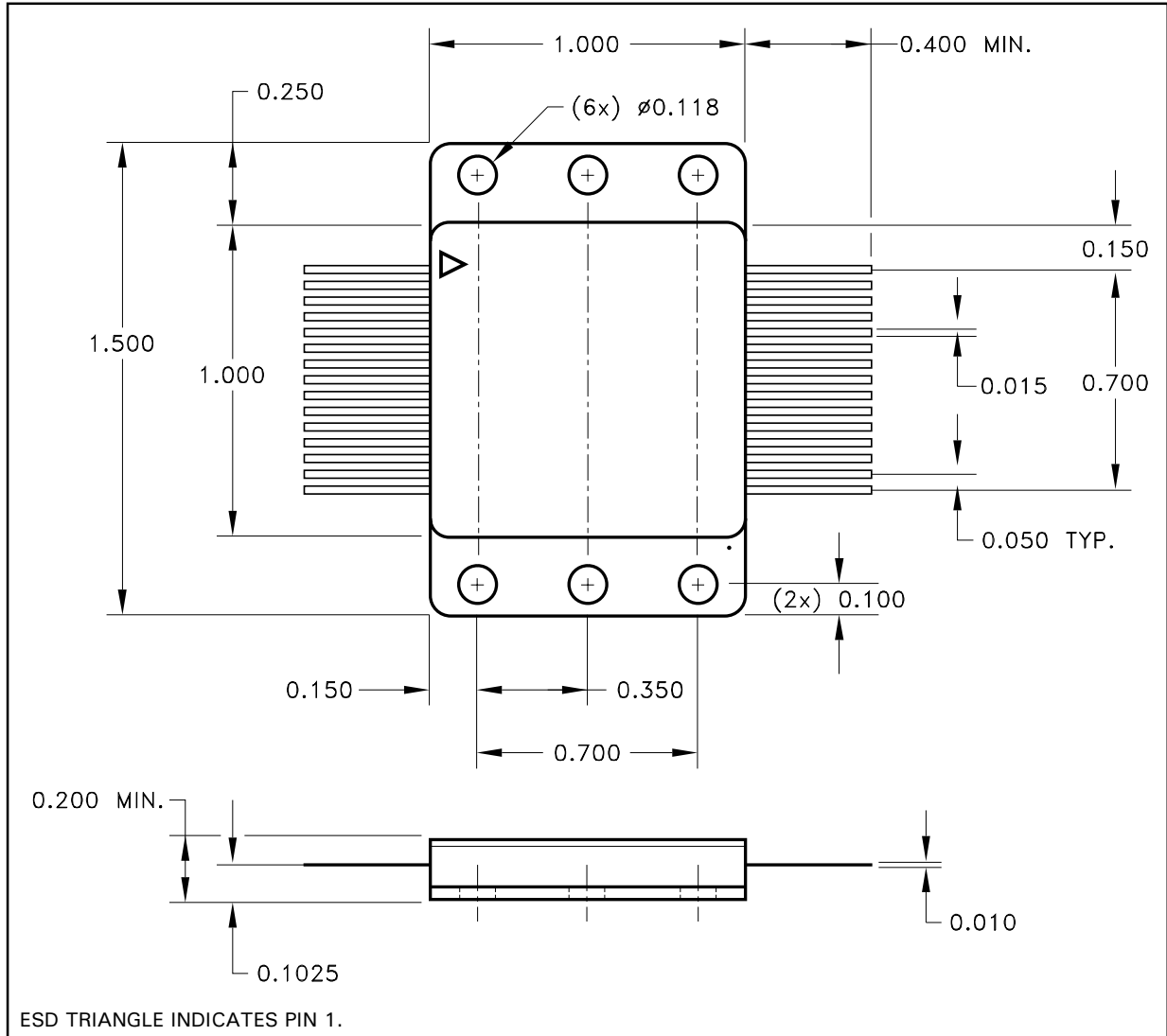

ALL DIMENSIONS ARE ± 0.010 INCHES UNLESS OTHERWISE LABELED.

ORDERING INFORMATION

PART NUMBER	SCREENING LEVEL
MSK 1922	Industrial

M.S. Kennedy Corp.
 4707 Dey Road, Liverpool, New York 13088
 Phone (315) 701-6751
 FAX (315) 701-6752
 www.mskennedy.com

The information contained herein is believed to be accurate at the time of printing. MSK reserves the right to make changes to its products or specifications without notice, however, and assumes no liability for the use of its products. Please visit our website for the most recent revision of this datasheet.