



M.S.KENNEDY CORP.

HIGH PERFORMANCE, HIGH VOLTAGE VIDEO DISPLAY DRIVER

1900

4707 Dey Road Liverpool, N.Y. 13088

(315) 701-6157

FEATURES:

- Ultra Fast Rise Time - 2.8nS Typical
- Wide Bandwidth - 200 MHz Typical
- Variable Gain - 0 to 100 V/V
- On Board Reference Output
- 50 Vpp Output Voltage Swing
- Blanking Capability
- User Adjustable Brightness and Contrast
- 25,000 V/ μ Sec Slew Rate
- Replaces TP1900 And Max 445

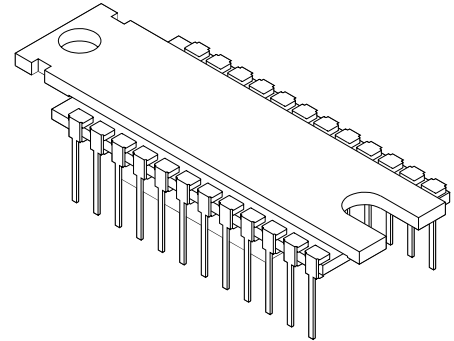

DESCRIPTION:

The MSK 1900 is a high performance, high voltage, variable gain video amplifier capable of directly driving high resolution video displays. The MSK 1900 features differential inputs and a linearly adjustable gain stage with an output offset adjustment which allows it to be a versatile performer well suited for many applications. A TTL level blanking input is available to set the output to a predetermined black level independent of signal input. The MSK 1900 is packaged in a cost effective, 24 pin power dip which can be bolted directly to a heat sink for efficient thermal management.

EQUIVALENT SCHEMATIC

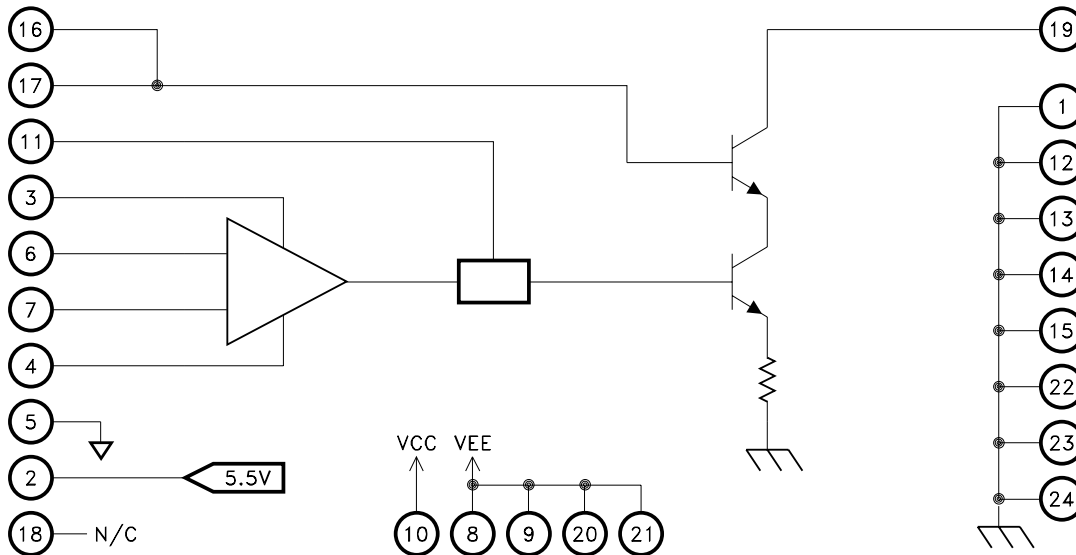

TYPICAL APPLICATIONS

- High Resolution Mono-Chrome Displays
- High Resolution RGB Displays
- High Speed, High Voltage Amplification for ATE

PIN-OUT INFORMATION

1 Ground	9 VEE	17 VCB
2 VREF	10 VCC	18 N/C
3 VOFF	11 Blank	19 Output
4 VGAIN	12 Ground	20 VEE
5 Ground	13 Ground	21 VEE
6 + Input	14 Ground	22 Ground
7 -Input	15 Ground	23 Ground
8 VEE	16 VCB	24 Ground

NOTE: All pins must be connected for proper operation if labeled.

ABSOLUTE MAXIMUM RATINGS ^⑤

+V _{HV}	High Voltage Supply(WRT VCB)	+65V	T _{ST}	Storage Temperature Range	-25°C to +150°C
+V _{CC}	Positive Supply Voltage	+12V	T _{LD}	Lead Temperature Range	+300°C (Solder 10 Seconds)
-V _{EE}	Negative Supply Voltage	-12V	T _J	Junction Temperature	+150°C
V _{ID}	Differential Input Voltage	2V	T _C	Case Operating Temperature	MSK 1900 0°C to +70°C
V _{GAIN}	Gain Adjust Input Voltage	-0.6V to +6V	Θ _{JC}	Thermal Resistance	(Junction to Case) 7.5°C/W
V _{OFF}	Offset Adjust Input Voltage	-0.6V to +6V			
V _{BLANK}	Blank Input Voltage	-0.6V to +6V			
V _{CB}	Common Base Supply	20V			

ELECTRICAL SPECIFICATIONS

T_c = 25°C unless otherwise specified

Parameter	Test Conditions ^①	MSK 1900			Units
		Min.	Typ.	Max.	
STATIC					
Quiescent Current	V _{CM} = 0V @ +10V	-	55	70	mA
	V _{CM} = 0V @ -10.5V	-	-75	-100	mA
High Voltage Supply ^②	WRT V _{CB}	20	60	65	V
Thermal Resistance to Case ^②		-	8	10	°C/W
INPUT					
Input Bias Current ^②	V _{CM} = 0V	-	±1	±50	μA
Common Base Current ^②	V _{CB} = 10V	-	30	40	mA
Blank Input Current ^②	V _{BLANK} = 0.4V	-	500	600	μA
	V _{BLANK} = 2.4V	-	300	400	μA
Offset Adjust Input Current ^②	V _{OFF} = 1V	-	2	10	μA
Gain Adjust Input Current ^②	V _{GAIN} = 5V	-	2	10	μA
Blank Input Pulse Width ^②	Normal Operation	30	-	-	nS
Common Mode Rejection Ratio ^②	V _{CM} = ±0.5V F = 10Hz	-	40	-	dB
Input Impedance ^②	Either Input F = DC	10K	20K	-	Ω
Input Capacitance ^②	Either Input	-	2	-	pF
Blank Mode Input Rejection ΔV ^{②④}	V _{BLANK} = 2.4V V _{IN} = 0.3V	-	-	±0.4	V
Gain Adjust Rejection ΔV ^{②④}	ΔV _{GAIN} = 5V	-	-	±2.0	V
Power Supply Rejection Ratio ^②	+V _{CC} and -V _{EE} = Nom ±5%	25	30	-	dB
OUTPUT					
Reference Output Voltage	I _{OUT} < 2mA	5.2	5.5	5.8	V
Output Current Blank Mode	V _{BLANK} = 2.4V V _{OFF} = 1V V _{GAIN} = 0V	-3	0	+3	mA
Output Current (Min Offset)	V _{OFF} = 0V V _{GAIN} = 5V	0.5	10	25	mA
Output Current (Max Offset)	V _{OFF} = 5V V _{GAIN} = 0V	80	100	120	mA
Voltage Gain (R _p = 200Ω)	V _{IN} = 0.6V F = 10KHz V _{GAIN} = 5V Either Input	80	100	120	V/V
Bandwidth ^{②③}	V _{OFF} = 0V	-	225	-	MHz
Transition Times ^{②③}	V _{GAIN} = 3V T _R = T _F < 0.5nS V _{OFF} = 1V	-	2.8	-	nS
Linearity Error ^②	V _{GAIN} = 1V V _{OFF} = 1V V _{CM} = 0.5V	-	-	±2	%GS
Gain Linearity ^②	V _{OFF} = 1V V _{IN} = 0.2V V _{CM} = 0.5V	-	-	±2	%
Thermal Distortion ^②		-	-	±2	%GS

NOTES:

- ① +V_{CC} = +10V, -V_{EE} = -10.5V, +V_{HV} = +70V, V_{CB} = +10V, V_{BLANK} = 0.4V, C_L = 6pF, R_p = 200Ω, V_{GAIN} = V_{OFF} = ±V_{IN} = 0V unless otherwise specified.
- ② Parameters shall be guaranteed by design if not tested. Typical parameters are representative of actual device performance but are for reference only.
- ③ Faster rise times are obtained without using test sockets. In addition, a peaking network must be used to achieve best performance.
- ④ Output voltage ΔV is the difference between +V_{HV} and V_{OUT}.
- ⑤ Continuous operation at or above absolute maximum ratings may adversely effect the device performance and/or life cycle.

APPLICATION NOTES

POWER SUPPLIES

The input stage of the MSK 1900 requires power supplies of +10V and -10.5V for optimum operation. The negative power supply can be increased to -12V if -10.5V is not available, but additional power dissipation will cause the internal temperature to rise. Both low voltage power supplies could be effectively decoupled with tantalum capacitors (at least 1 μ F) connected as close to the amplifiers pins as possible. The MSK 1900 has internal 0.01 μ F capacitors that also improve high frequency performance. Additionally, it is also recommended to put 0.1 μ F decoupling capacitors on the +10V and -10.5V supplies as well.

The high voltage power supply (+VHV) is connected to the amplifiers output stage and must be kept as stable as possible. The internal Rp is connected to +VHV and as such, the amplifiers DC output is directly related to the high voltage value. The +VHV pin of the hybrid should be decoupled to ground with as large a capacitor as possible to improve output stability.

VCB

The VCB input is the base connection to the output stage consisting of a common base, high voltage stage and a high speed, low voltage current amplifier in a cascode arrangement. This input requires a very stable 10V DC nominal voltage. Any AC signals at this point will be amplified and reflected in the output. The PSRR of the output stage is directly related to the stability of this VCB voltage.

SUPPLY SEQUENCING

The power supply sequence is +VHV, VCC, VEE followed by the other DC control inputs. If power supply sequencing is not possible, the time difference between each supply should be less than five milliseconds. If the DC control signals are being generated from a low impedance source other than the VREF output, reverse biased diodes should be connected from each input (VGAIN, VOFF) to the +VCC pin. This will protect the inputs until +VCC is turned off.

VIDEO OUTPUT

When power is first applied and VIN = VGAIN = VOFF = 0V, the output will be practically at the +VHV rail voltage. The output voltage is a function of the value of Rp and also the VGAIN and VOFF DC inputs. The bandwidth of the amplifier largely depends on both Rp and Lp. With +VHV set to +70V and total Rp = 200 Ω , the device is capable of approximately 62Vpp total output swing.

The MSK 1900 is conservatively specified with low values for external Lp which yield about 5% overshoot. Additional peaking can be obtained by using a high self-resonant frequency inductor in series with +VHV pin. Since this value of inductance can be very dependent on circuit layout, it is best to determine its value by experimentation. A good starting point is typically 0.47 μ H for the MSK 1900.

VIDEO INPUTS

The analog inputs (\pm VIN) are designed to accept RS343 signals, \pm 0.714VPP, and operate properly with a common mode range of \pm 0.5V with respect to ground. Therefore, it is recommended that the input signal be limited to \pm 1.3V with respect to ground, (signal + common mode). Although large offsets of \pm 2V (with respect to ground, signal included) can be tolerated without damage to the hybrid, output linearity suffers and therefore it is not recommended.

OUTPUT PROTECTION

The output pin of the MSK 1900 can be protected from transients by connecting reversed biased ultra-low capacitance diodes from the output pin to both +VHV and ground. The output can also be protected from arc voltages by inserting a small value (50-100 Ω) resistor in series with the amplifier. This resistor will reduce system bandwidth along with the load capacitance, but a series inductor can reduce the problem substantially.

VGAIN CONTROL INPUT

The VGAIN control (contrast) input is designed to allow the user to vary the video gain. By simply applying a DC voltage from 0V to VREF, the video gain can be linearly adjusted from 0 to 100V/V. The VGAIN input should be connected to the VREF pin through a 5k Ω pot to ground. For convenient stable gain adjustment, a 0.1 μ F bypass capacitor should be connected near the VGAIN input pin to prevent output instability due to noisy sources. Digital gain control can be accomplished by connecting a D/A converter to the VGAIN pin. However, some temperature tracking performance may be lost when using an external DC voltage source other than VREF for gain adjustment.

The overall video output of the MSK 1900 can be characterized using the following expression:

$$V_{pp} = V_{HV} - V_{OUT}$$

$$V_{HV} - V_{OUT} = (V_{IN})(V_{GAIN})(R_p)(0.08)$$

Here is a sample calculation for the MSK1900:
Given information

- VIN = 0.7V
 - VGAIN = 1VDC
 - Rp = 200 Ω (external)
 - VHV = 70VDC
- $$V_{HV} - V_{OUT} = (0.7V)(1V)(.08)(200\Omega)$$
- $$V_{HV} - V_{OUT} = 11.2V_{pp} \text{ Nominal}$$

The expected video output would swing from approximately +70V to +58.8V assuming that VOFF = 0V. This calculation should be used as a nominal result because the overall gain may vary as much as \pm 10% due to internal high speed device variations. Changing ambient conditions can also effect the video gain of the amplifier slightly. It is wise to connect all video amplifiers to a common heat sink to maximize thermal tracking when multiple amplifiers are used in applications such as RGB systems. Additionally, only one of the VREF outputs should be shared by all three amplifiers. This voltage should be buffered with a suitable low-drift op-amp for best tracking performance.

APPLICATION NOTES CON'T

V_{OFF}

V_{OFF} is the output offset (brightness) control used to set the output quiescent current and consequently the DC output voltage (black level). Output quiescent current adjustment range is from several μA to 100mA nominal (80 to 130 mA actual). Normally a 5K potentiometer is connected between V_{REF} and GND to this input, but any 0 - 5.5V external DC source may be used. A 0.1 μF capacitor should be connected from this pin to signal ground to improve the amplifier's stability.

V_{REF} OUTPUT

The MSK 1900 has an on board buffered DC zener reference output. The V_{REF} output is nominally 5.5V DC and has full temperature test limits of 5.2V to 5.8V DC. This output is provided for gain and offset adjustment and can source up to 4mA of current.

BLACK LEVEL

The voltage developed across the external load resistor with a 0V video input to the MSK 1900 is the black level. This voltage may be changed by adjusting the load resistor or by varying the output quiescent current of the MSK 1900 as described in V_{OFF} above. The black level could also be effected by the V_{GAIN} control voltage if the video input has a DC component. AC coupling of the video input will prevent this phenomenon from occurring.

BLANK INPUT

The video input can be electrically disconnected from the amplifier by applying a TTL high input to the blank pin. When this occurs, the output will be set to approximately $+V_{HV}$. The V_{GAIN} and V_{OFF} control pins have little or no effect on the output when it is in blank mode.

When the TTL compatible blank input is not used, the pin must be connected to ground to enable the amplifier. The blank input will float high when left unconnected which will disable the video.

THERMAL MANAGEMENT

The MSK 1900 package is electrically isolated from the internal circuitry, allowing direct connection to a heat sink.

The power dissipation of the amplifier depends mainly on the load requirements, bandwidth, pixel size, black level and the value of the external R_p . Refer to the following table for typical power levels for selected video conditions:

POWER DISSIPATION TABLE
($T_C = 25^\circ C$, $V_{HV} = 70V$, $R_p = 200\Omega$)

$V_O - V_{BLACK}$	Duty Cycle %	IC P_D Watts	LOAD Watts	TOTAL P_D Watts
0	0	1.6	0	1.6
35	100	7.8	6.1	13.9
35	80	6.5	4.9	11.4
50	80	5.6	10	15.6

TYPICAL CONNECTION CIRCUIT

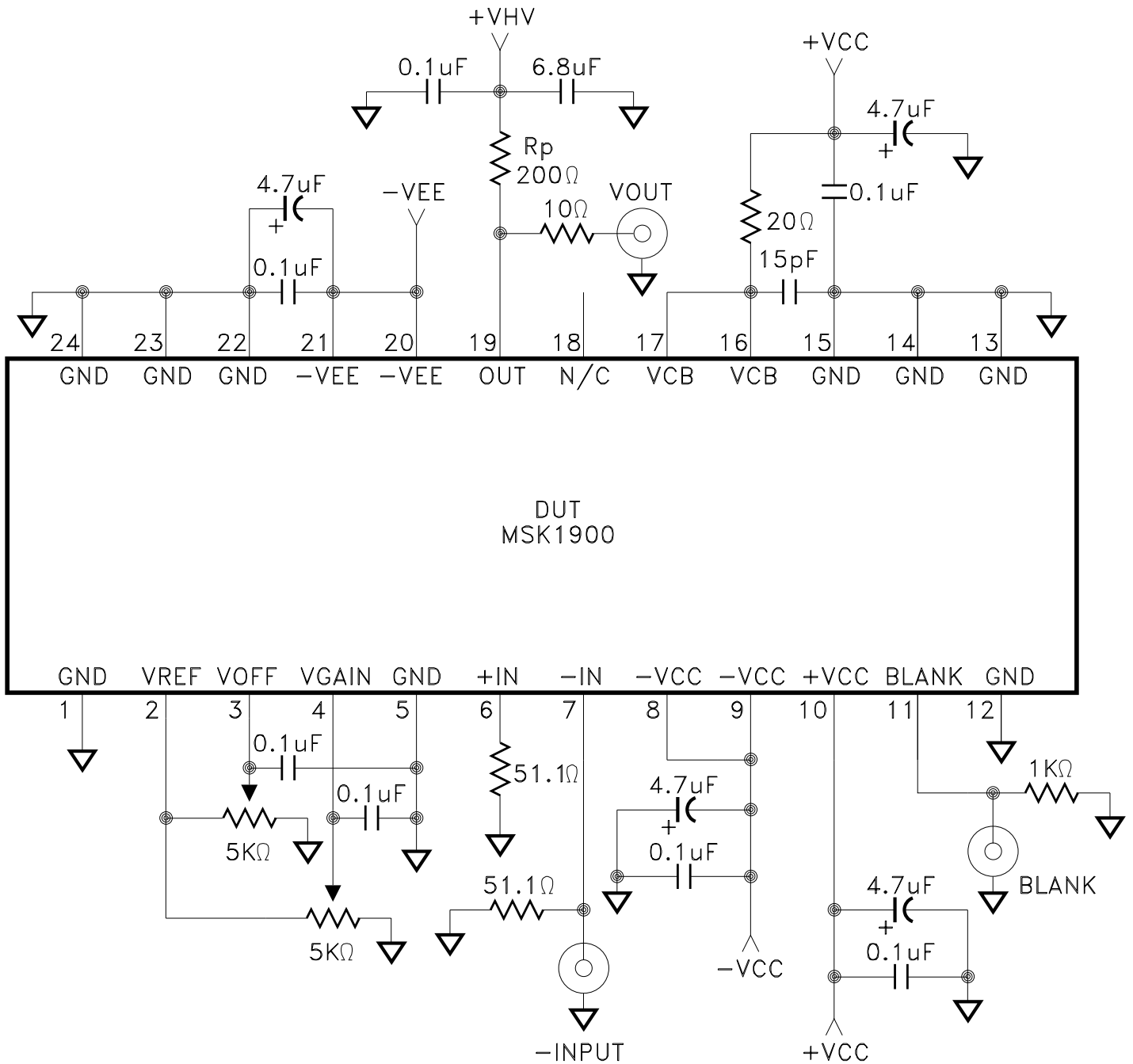

The connections shown above are for the MSK 1900 evaluation board. +Vcc should be connected to VCB through a 20Ω resistor with a 15pF capacitor to ground. This will help to filter power supply noise and provide a stable voltage at VCB. Rp is an external component and must not be located near ground planes if possible. A high quality resistor such as Bradford Electronics P/N FP10-200 is required for optimum response times.

MECHANICAL SPECIFICATIONS

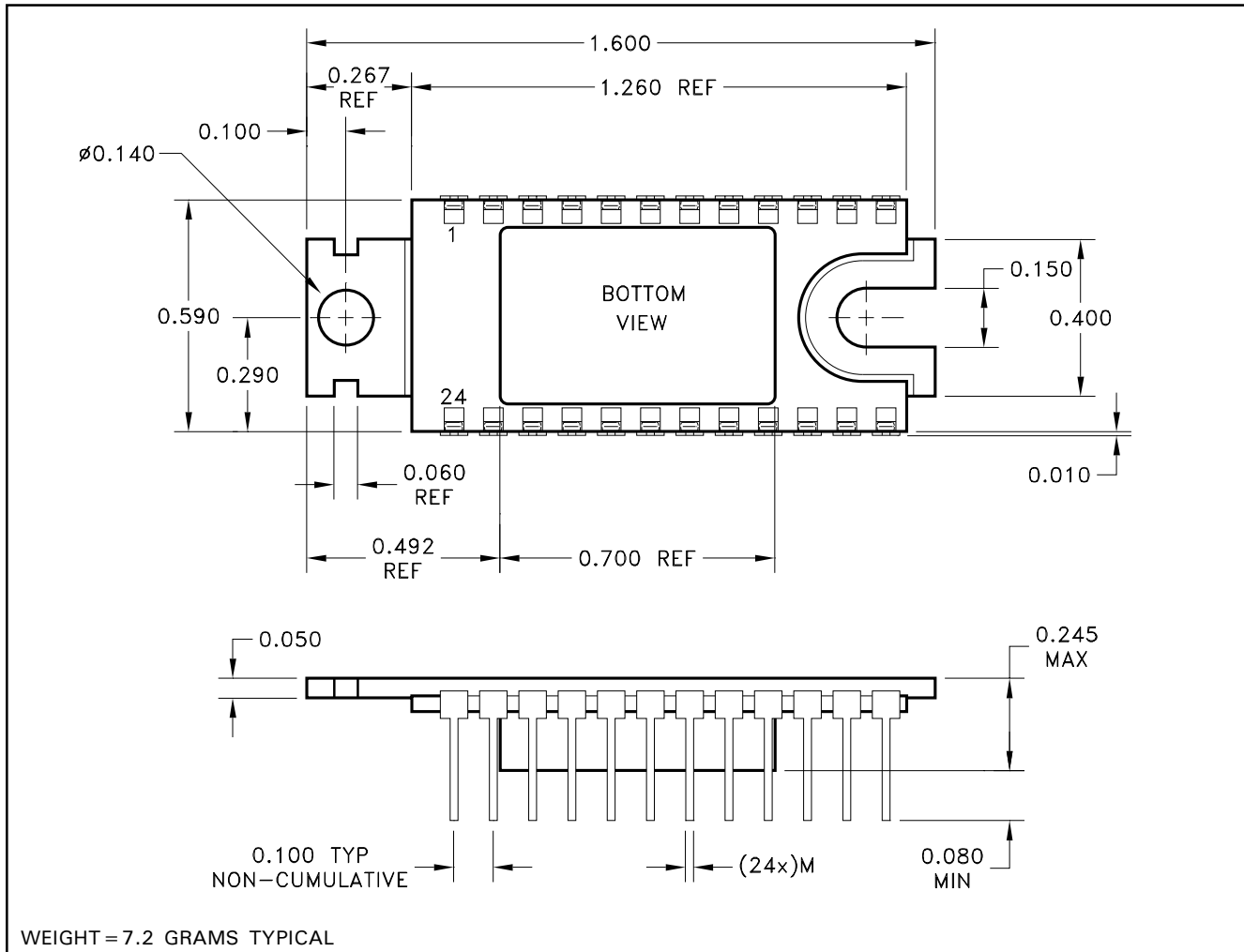

ALL DIMENSIONS ARE $\pm .010$ INCHES UNLESS OTHERWISE LABELED

ORDERING INFORMATION

Part Number	Screening Level
MSK1900	Industrial

M.S. Kennedy Corp.
 4707 Dey Road, Liverpool, New York 13088
 Phone (315) 701-6751
 FAX (315) 701-6752
www.mskennedy.com

The information contained herein is believed to be accurate at the time of printing. MSK reserves the right to make changes to its products or specifications without notice, however, and assumes no liability for the use of its products. Please visit our website for the most recent version of this datasheet.