



HIGH VOLTAGE/HIGH CURRENT OPERATIONAL AMPLIFIER

181

M.S.KENNEDY CORP.

4707 Dey Road Liverpool, N.Y. 13088

(315) 701-6751

FEATURES:

- Available to DSCC SMD 5962-92152
- Low Cost
- High Voltage Operation:
 - Single Supply: +8V to +60V
 - Dual Supply: $\pm 4V$ to $\pm 30V$
- High Output Current: 3 Amp Continuous
- High Speed: 10V/ μ S
- Low Quiescent Current: 20 mA Typ.
- Adjustable Current Limits
- Thermal Shutdown
- Monolithic Technology
- Enable/Status Pin For Output Disable Control

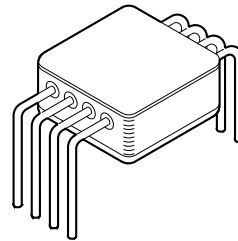

MSK181

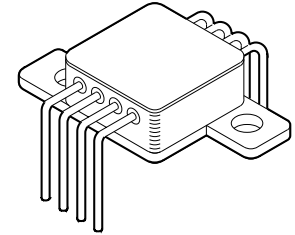

MSK181Z

DESCRIPTION:

The MSK 181 is a high power monolithic operational amplifier ideal for use with a wide variety of loads. With operation from either single or dual supplies, the MSK 181 offers excellent design flexibility. Power dissipation is kept to a minimum with a quiescent current rating of only 20mA, while 3 Amps of continuous available output current makes the MSK 181 a very good low cost choice for motor drive circuits and audio amplification. The MSK 181 is internally protected against current overloads and overtemperature conditions. Current limit can also be user-selected through the use of a resistor/potentiometer or voltage out/current out DAC. The MSK 181 is packaged in a hermetically sealed 8 pin power dip and the MSK 181Z is offered with bolt down tabs for applications that require heat sinking.

EQUIVALENT SCHEMATIC

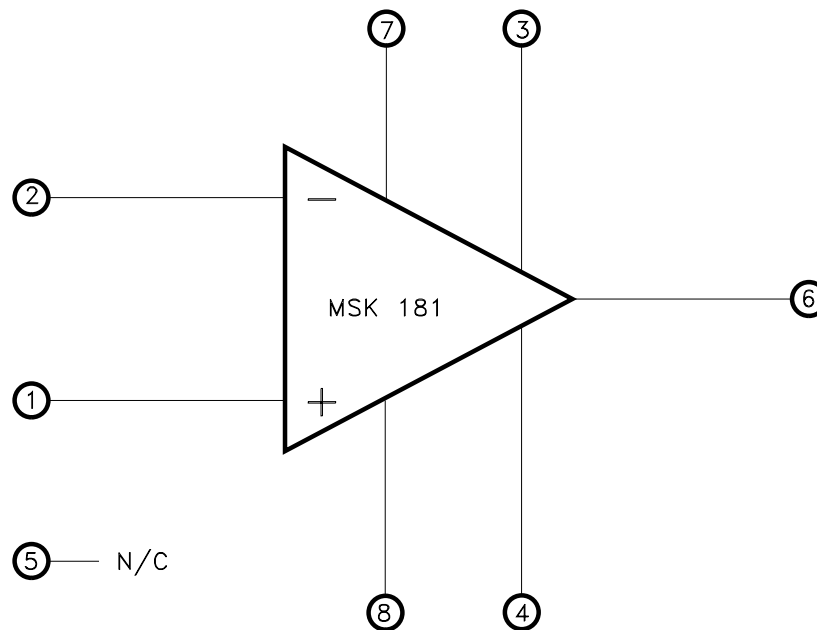

TYPICAL APPLICATIONS

- Servo Driver
- Actuator Driver
- Audio Amplifier
- Power Supplies

PIN-OUT INFORMATION

1	+ VIN	8	-Vcc
2	-VIN	7	+ Vcc
3	ILIM	6	Output
4	E/S	5	N/C

ABSOLUTE MAXIMUM RATINGS ^⑧

V _{CC}	Total Supply Voltage	60V
± I _{OUT}	Output Current (within S.O.A.)	5A
V _{IND}	Input Voltage (Differential)	± 29.5V
V _{IN}	Input Voltage (Common Mode)	+ 27V/-29V
T _J	Junction Temperature	Internal Protection (See Application Note)

T _{ST}	Storage Temperature Range	-65°C to +150°C
T _{LD}	Lead Temperature Range	300°C (10 seconds)
T _C	Case Operating Temperature (MSK181G/E) See Note 6	-40°C to +125°C (MSK181)
R _{TH}	Thermal Resistance Junction to Case	2.5°C/W

ELECTRICAL SPECIFICATIONS

Parameter	Test Conditions ^①	Group A Subgroup	MSK181G/E			MSK181			Units
			Min.	Typ.	Max.	Min.	Typ.	Max.	
STATIC									
Supply Voltage Range ^②		-	± 4	-	± 30	± 4	-	± 30	V
Quiescent Current	V _{IN} = 0V	1	-	± 17	± 20	-	± 17	± 23	mA
		2,3	-	± 17	± 20	-	-	-	mA
Quiescent Current	Shutdown Mode V _{IN} = 0V	-	-	± 6	-	-	± 6	-	mA
INPUT									
Input Offset Voltage	V _{IN} = 0V	1	-	± 2	± 10	-	± 2	± 15	mV
Input Offset Voltage Drift	V _{IN} = 0V	-	-	± 30	-	-	± 30	-	µV/°C
Input Bias Current ^②	V _{IN} = 0V	1	-	± 100	± 500	-	± 100	± 750	nA
Input Offset Current ^②	V _{IN} = 0V	1	± 1	± 5	± 50	-	± 5	± 75	nA
Input Impedance	f = DC	-	-	10 ⁷	-	-	10 ⁷	-	Ω
Input Capacitance	f = DC	-	-	6	-	-	6	-	pF
Common Mode Rejection Ratio ^②	(V _{CC} -0.1) ≤ V _{IN} ≤ (+ V _{CC})-3V	1	80	95	-	75	95	-	dB
Input Voltage Noise Density	f = 1KHz	-	-	90	-	-	90	-	nV/√Hz
OUTPUT									
Output Voltage Swing	I _{OUT} = 0.6A	1	± 27	± 28	-	± 26	± 28	-	V
	I _{OUT} = 3.0A	1	± 25.5	± 26	-	± 24	± 26	-	V
Output Current	DC= Continuous	1	± 3	-	-	± 3	-	-	A
Current Limit	RCL= 34kΩ 0.1%	1	1.425	1.5	1.575	1.350	1.5	1.650	A
Shutdown Input ^②	V _{E/S} High- Output Enabled E/S Open or High	4	-27.5	-	-	-27.5	-	-	V
	V _{E/S} Low- Output Disabled E/S Forced Low	4	-	-	-29	-	-	-29	V
	I _{E/S} High- Output Enabled E/S Open or High	-	-	-65	-	-	-65	-	µA
	I _{E/S} Low- Output Disabled E/S Forced Low	-	-	-70	-	-	-70	-	µA
Output Disable Time		-	-	1	-	-	1	-	µS
Output Enable Time		-	-	3	-	-	3	-	µS
TRANSFER CHARACTERISTICS									
Slew Rate	A _V = 1 V _{OUT} = 50Vp-p R _L = 500Ω	4	6.0	10	-	5.0	10	-	V/µS
Open Loop Voltage Gain ^②	V _{OUT} = ± 25V R _L = 1KΩ	4	90	98	-	88	98	-	dB
Settling Time ± 0.1% ^②	A _V = 10 50V Step	-	-	15	-	-	18	-	

NOTES:

- ① Unless otherwise specified ± V_{CC}= ± 30VDC and E/S pin is open.
- ② Devices shall be capable of meeting the parameter, but need not to be tested. Typical parameters are for reference only.
- ③ Industrial grade and 'E' suffix devices shall be tested to subgroups 1 and 4 unless otherwise specified.
- ④ Military grade devices ('G' suffix) shall be 100% tested to subgroups 1,2,3 and 4.
- ⑤ Subgroup 1,4 T_A= T_C= + 25°C
Subgroup 2 T_A= T_C= + 125°C
Subgroup 3 T_A= T_C= -40°C
- ⑥ Refer to SMD 5962-92152 for electrical parameters for devices purchased as such.
- ⑦ The operating temperature range is -55° to + 125°C if the device is powered. The minimum cold start temperature is -40°C.
- ⑧ Continuous operation at or above absolute maximum ratings may adversely effect the device performance and/or life cycle.

APPLICATION NOTES

POWER SUPPLIES:

The MSK 181 maximum total supply voltage is specified as 60V. However, dual and unbalanced power supply operation is permissible as long as total supply voltage does not exceed 60V.

POWER SUPPLY BYPASSING:

Power supply terminals must be effectively decoupled with a high and low frequency bypass circuit to avoid power supply induced oscillation. An effective decoupling scheme consists of a 0.1µF ceramic capacitor in parallel with a 10µF tantalum capacitor for each power supply pin to ground. In addition, it is recommended that a 0.01µF capacitor be placed between ±Vcc as close to the MSK 181 as possible.

CURRENT LIMIT:

The MSK 181 offers accurate, user-selectable current limit. Unlike typical designs that use a power resistor in series with the output to sense load, the MSK 181 senses the load indirectly and therefore does not require a resistor to handle the full output current. Current limit is selected by controlling the input to the I_{LIM} pin.

The easiest method is to use a resistor or potentiometer connected between -Vcc and the I_{LIM} pin. Use the following equation to select proper resistor value:

$$R_{CC} = \frac{71,250}{I_{LIM}} - 13.75K\Omega$$

A low level control signal (0-330µA) can also be used to control the current level digitally. If the pin is left open, the current is programmed to OA, while connecting I_{LIM} directly to -Vcc sets the output current to it's maximum, typically 5A.

SAFE OPERATING AREA:

The safe operating area curve is a graphical representation of the power handling capability of the amplifier under various conditions. Power dissipation of the device is equal to the product of the voltage across the output transistor times the output current. As can be seen in the curve, safe operating current decreases with an increase in temperature as well as an increase in the voltage across the output transistor. Therefore, for maximum amplifier performance it is important to keep case temperature as low as possible and to keep ±Vcc as close to the output rail as achievable.

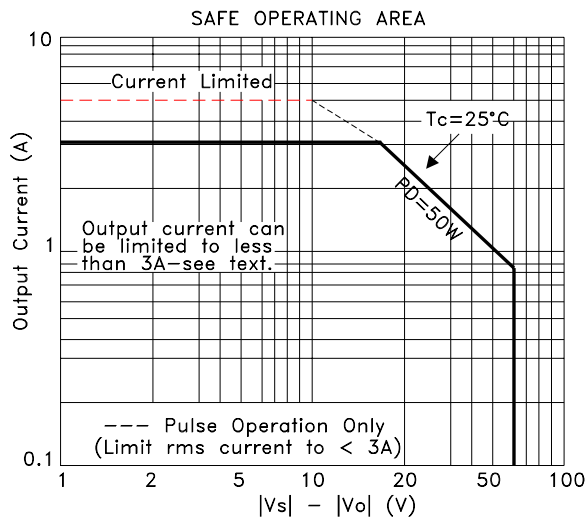

THERMAL PROTECTION:

The MSK 181 is equipped with thermal protection circuitry that protects the amplifier from damage caused by excessive junction temperature. The output is disabled when the junction temperature reaches approximately 160°C. After the junction temperature cools to approximately 140°C, the output is again enabled. The thermal protection may cycle on and off depending on the output load and signal conditions; this may have an undesirable effect on the load.

It should be noted that even though this internal protection circuitry does protect against overload conditions, it does not take the place of proper heat sinking. For reliable operation, junction temperature should be limited to 150°C, maximum.

ENABLE/STATUS PIN:

This pin actually has a dual function. First, when the pin is forced low, the output stage is disabled. Second, it can be monitored to determine if the device is in thermal shutdown. These functions can be used on the same device with either single or dual supplies. For normal operation, the E/S pin must be left open or pulled at least 2.4 volts above the negative rail. In noisy applications, a small value capacitor between the E/S pin and -Vcc may be required.

To disable the output, the user must pull the E/S pin low, no greater than 0.8V above -Vcc. To once again enable the device, the E/S pin must be brought at least 2.4 volts above -Vcc or disconnected. It should be noted that when the E/S pin is high, the internal thermal shutdown is still active.

If the E/S pin is used to monitor thermal shutdown, during normal operation the voltage on the E/S pin is typically 3.5V above -Vcc. Once shutdown has occurred this voltage will drop to approximately 350mV above -Vcc.

COMPENSATION:

For normal operation output compensation is not typically required. However, if the MSK 181 is intended to be driven into current limit the user may find that an R/C network is required. A snubber network from the output to ground will provide stability. If driving large capacitive or inductive loads, a snubber network will also enhance stability. Typically 3Ω to 10Ω in series with 0.01µF is acceptable.

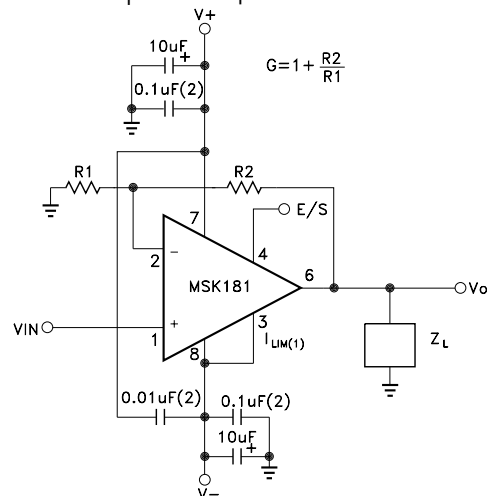

NOTE: (1) I_{LIM} connected to V- achieves the maximum current limit, 5A(peak). (2) Connect capacitors directly to package power supply pins.

TYPICAL CONNECTION DIAGRAM

APPLICATION NOTES cont.

RESISTOR METHOD

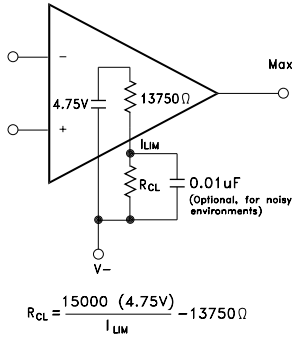

DAC METHOD (Current or voltage)

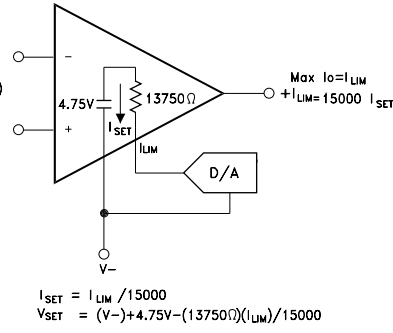

DESIRED CURRENT LIMIT	RESISTOR(1) (R _{CL})	CURRENT (I _{SET})	VOLTAGE (V _{SET})
0A	I _{LIM} Open	0uA	(V-)+4.75V
1A	57.6KΩ	67uA	(V-)+3.8V
2.5A	14.7KΩ	167uA	(V-)+2.5V
3A	10KΩ	200uA	(V-)+2V
4A	4.02KΩ	267uA	(V-)+1.1V
5A	I _{LIM} Connected to V-	333uA	(V-)

NOTE: (1) Resistors are nearest standard 1% values.

Figure 1 Adjustable Current Limit

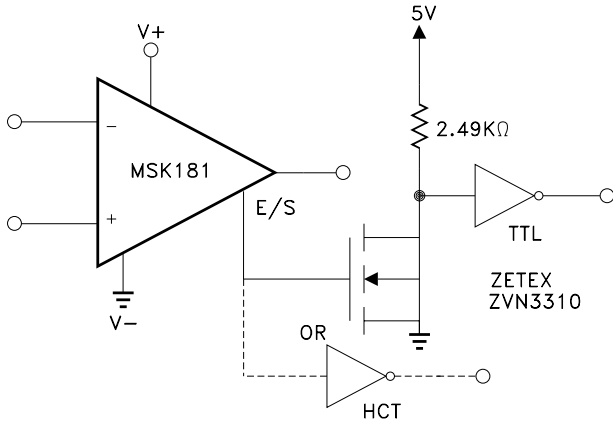
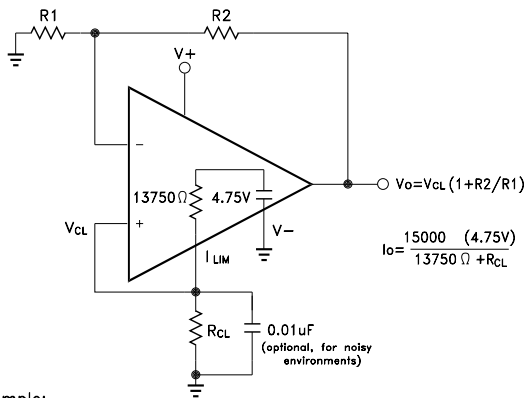

Figure 3

Thermal Shutdown Status With a Single Supply



For Example:
 If $I_{LIM} = 3A$, $R_{CL} = 10K\Omega$
 $V_{CL} = \frac{10K\Omega \cdot 4.75V}{(10K\Omega + 13750\Omega)} = 2V$
 Desired $V_o = 20V$, $G = \frac{20}{2} = 10$
 $R_1 = 1K\Omega$ and $R_2 = 9K\Omega$

Figure 5 Voltage Source

Uses voltage developed at I_{LIM} pin as a moderately accurate reference voltage.

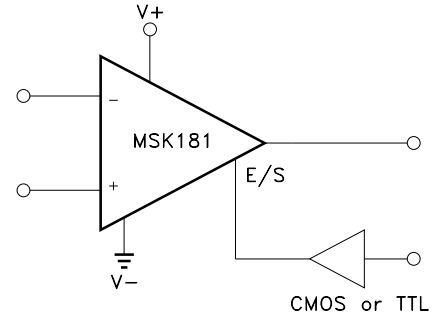

Figure 2 Output Disable with a Single Supply

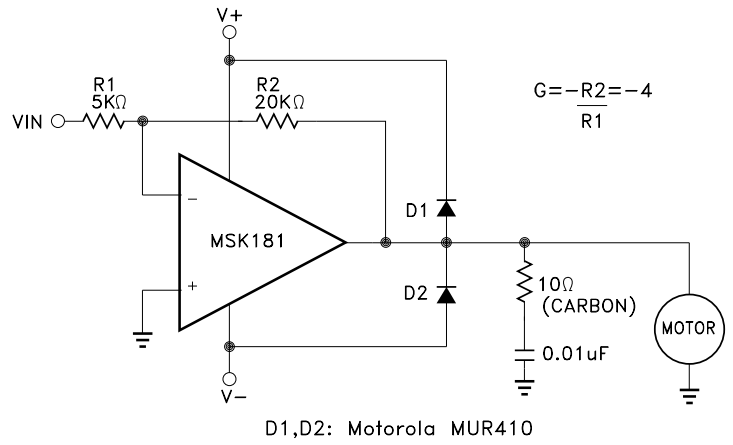

Figure 4 Motor Drive Circuit

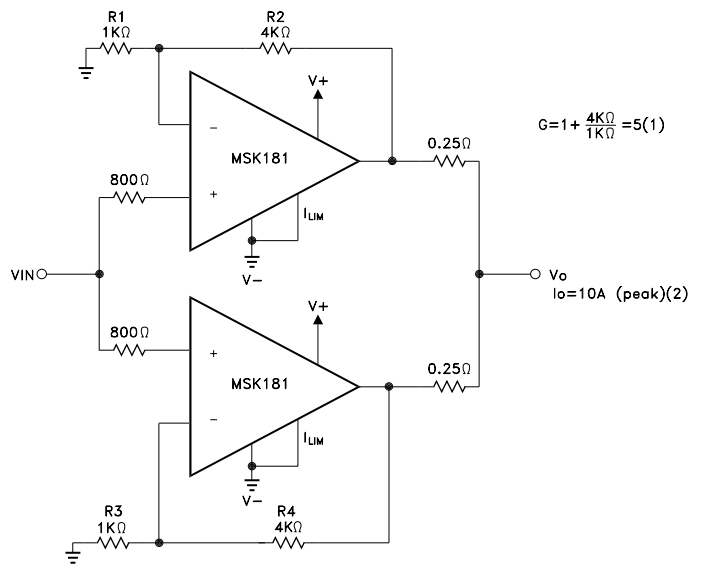
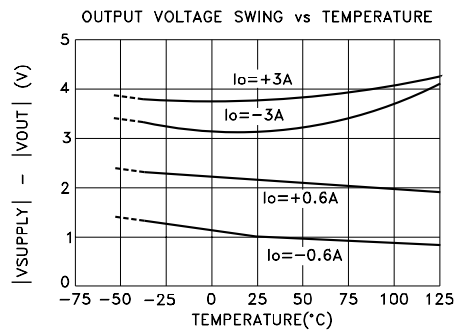
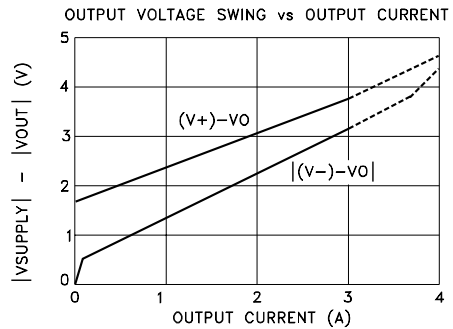
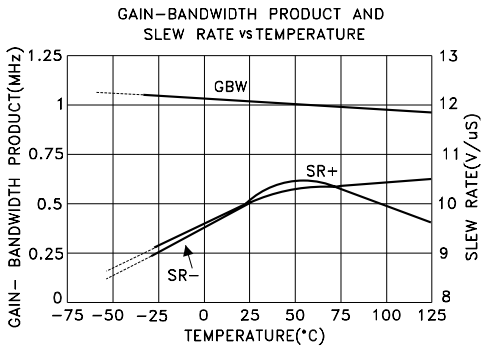
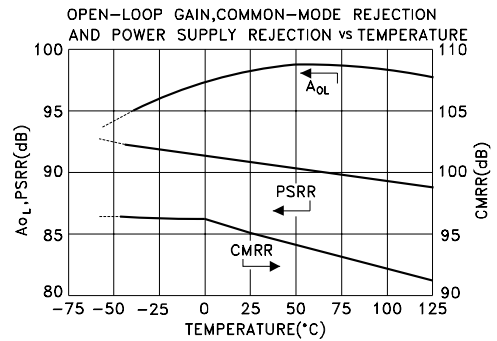
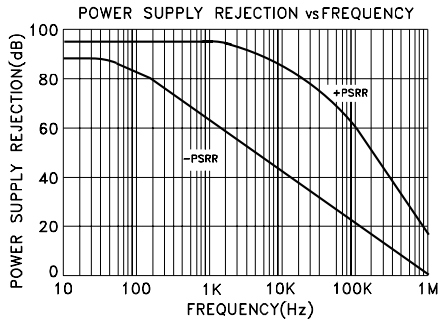
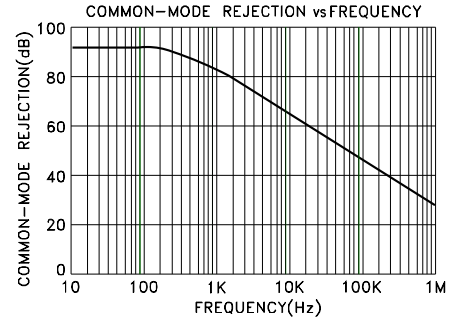
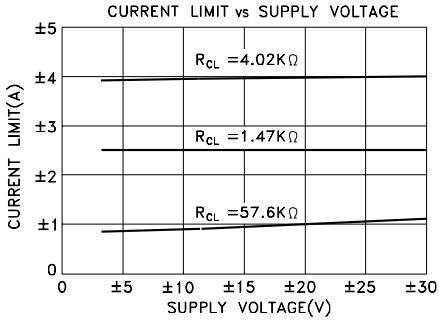
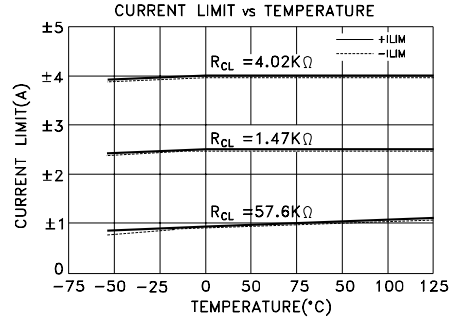
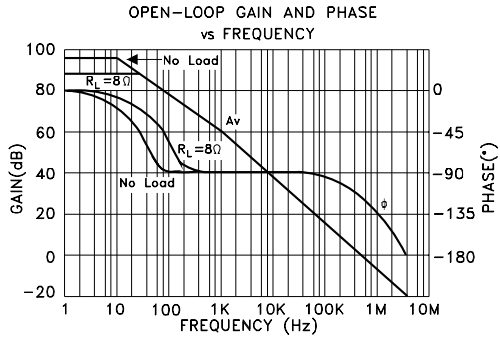
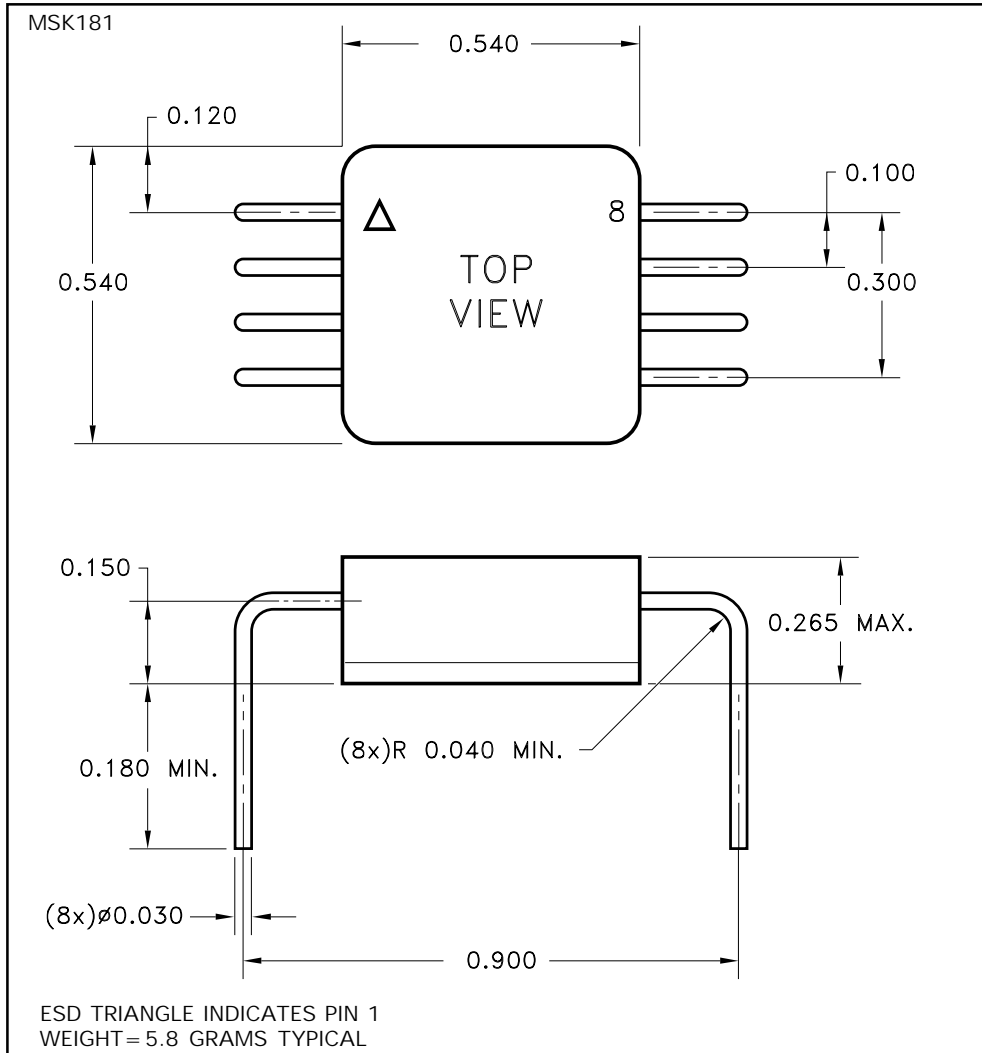

Figure 6 Parallel Output For Increased Output Current

TYPICAL PERFORMANCE CURVES



MECHANICAL SPECIFICATIONS



ALL DIMENSIONS ARE ± 0.010 INCHES UNLESS OTHERWISE LABELED.

ORDERING INFORMATION

Part Number	Screening Level
MSK181	Industrial
MSK181E	Extended Reliability
MSK181G	MIL-PRF-38534 Class G (REDUCED TEMP RANGE)
5962-92152-03	DSCC SMD

MECHANICAL SPECIFICATIONS CONT'D

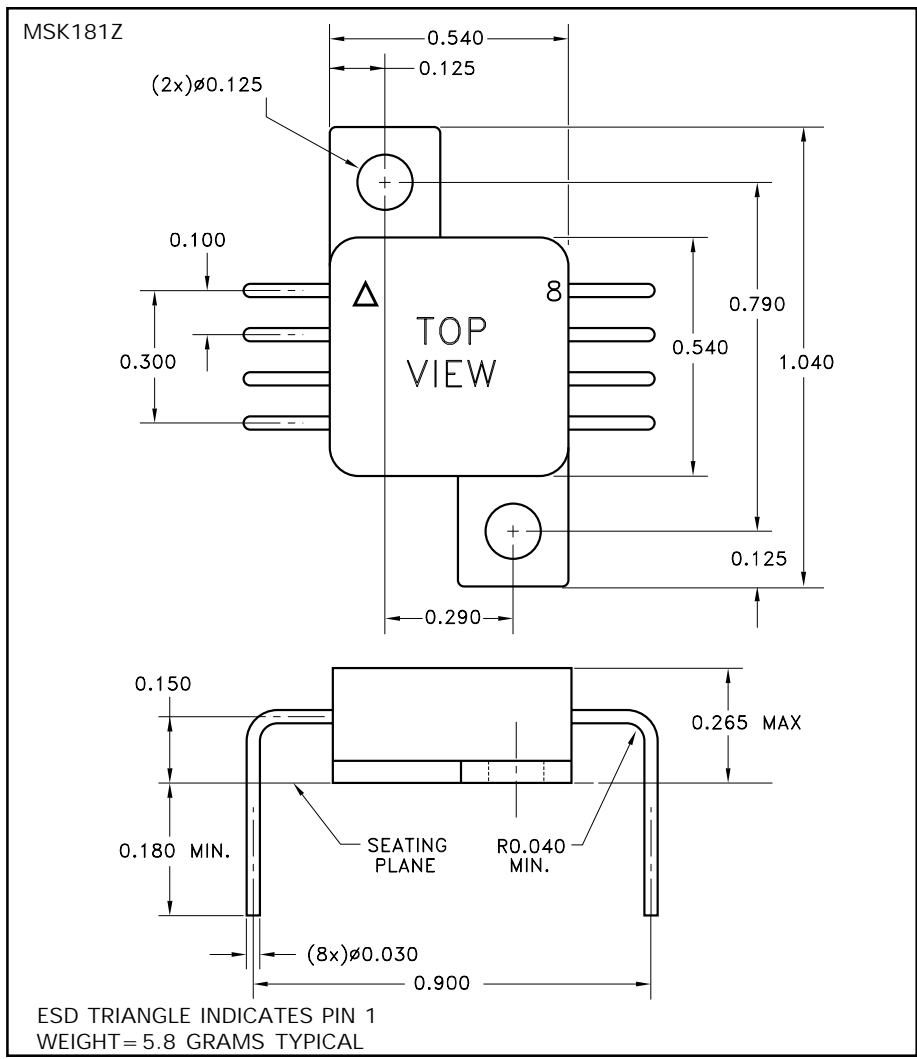

ALL DIMENSIONS ARE ±0.010 INCHES UNLESS OTHERWISE LABELED.

ORDERING INFORMATION

Part Number	Screening Level
MSK181Z	Industrial
MSK181EZ	Extended Reliability
MSK181GZ	MIL-PRF-38534 Class G (REDUCED TEMP RANGE)
5962-92152-03	DSCC SMD

M.S. Kennedy Corp.
 4707 Dey Road, Liverpool, New York 13088
 Phone (315) 701-6751
 FAX (315) 701-6752
 www.mskennedy.com

The information contained herein is believed to be accurate at the time of printing. MSK reserves the right to make changes to its products or specifications without notice, however, and assumes no liability for the use of its products. Please visit our website for the most recent revision of this datasheet.