



M.S.KENNEDY CORP.

ULTRA HIGH VOLTAGE HIGH SPEED DIFFERENTIAL OP-AMP

130

4707 Dey Road Liverpool, N.Y. 13088

(315) 701-6751

FEATURES:

- Wide Supply Voltage Range 15V to 400V
- Fast Slew Rate - 300 V/ μ S Typ.
- FET Input - Accurate DC Specifications
- Electrically Isolated Case
- Low Cost Innovative Packaging
- Very Low Quiescent Current - 6mA Typ.
- Output Current to \pm 200mA
- Adjustable Current Limit

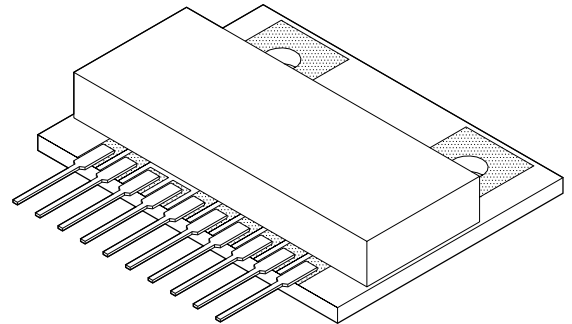

DESCRIPTION:

The MSK 130 is a high speed, high voltage differential amplifier designed for output currents up to \pm 200mA. Since the MSK 130 utilizes external compensation, it exhibits wide bandwidth and greater stability over a wide gain range. High frequency, high voltage instrumentation circuits and electrostatic transducers are just a sample of the applications that the MSK 130 is well suited for. The device is packaged in a 10 pin insulated ceramic SIP with holes for direct heat sink attachment.

EQUIVALENT SCHEMATIC

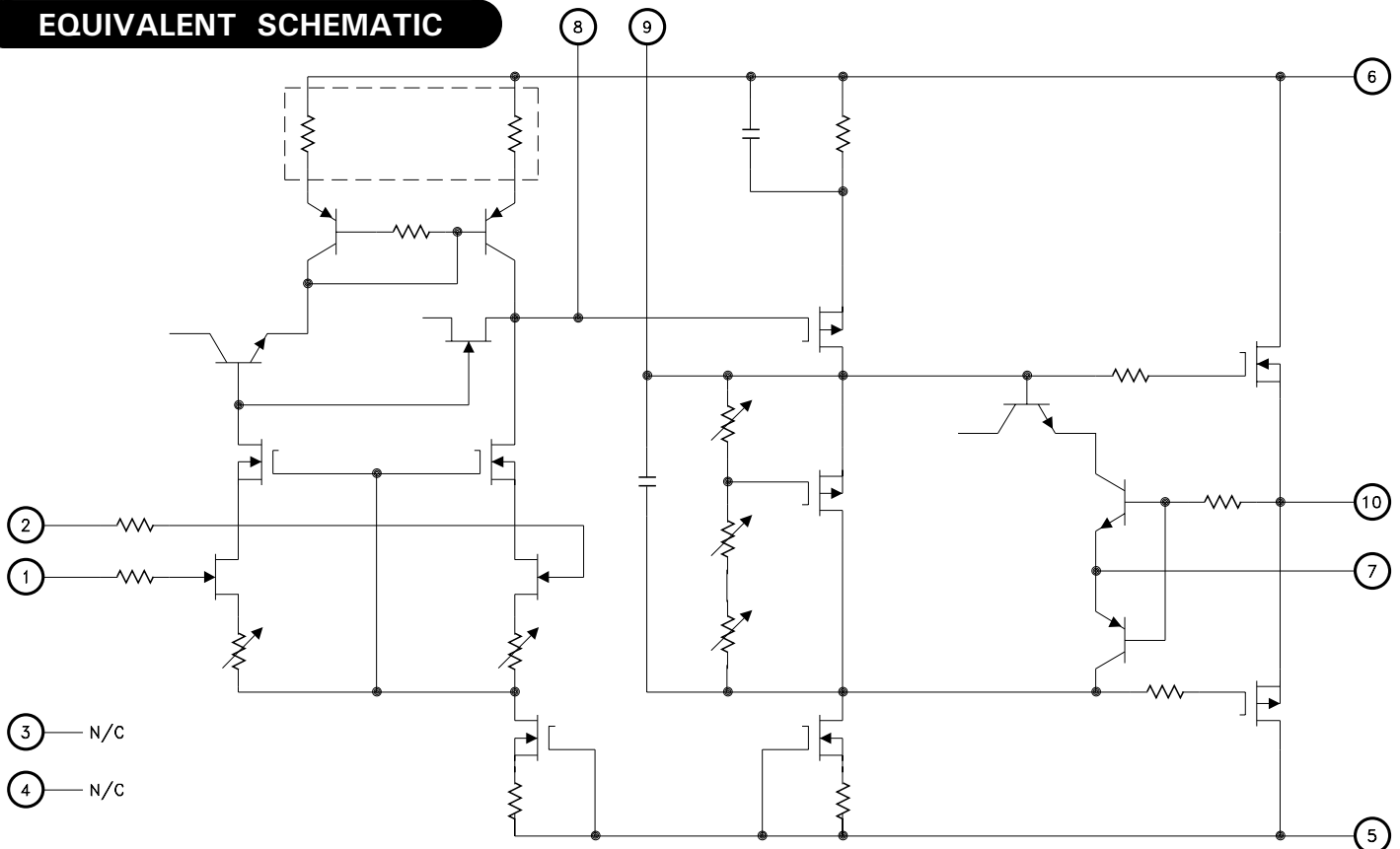

TYPICAL APPLICATIONS

- Ultra-High Voltage Supplies
- FET Input Instrumentation Amplifiers
- Electrostatic Deflection
- Electrostatic Transducers
- Piezo Transducer Excitation

PIN-OUT INFORMATION

- | | |
|-----------------|-----------|
| 1 -Input | 10 Output |
| 2 +Input | 9 Comp2 |
| 3 No Connection | 8 Comp1 |
| 4 No Connection | 7 Isense |
| 5 -Vcc | 6 +Vcc |

ABSOLUTE MAXIMUM RATINGS

V_{CC}	Supply Voltage (Total)	400V	T_{ST}	Storage Temperature Range	-65°C to +150°C
I_{OUT}	Output Current	±300mA	T_{LD}	Lead Temperature Range	220°C (10 Seconds)
V_{IND}	Differential Input Voltage	±25V	T_J	Junction Temperature	150°C
V_{INCM}	Common Mode Input Voltage	± V_{CC}	T_C	Case Operating Temperature Range (MSK130)	-55°C to +125°C
R_{TH}	Thermal Resistance	21°C/W Junction to Case @ 125°C (Output Devices)			

ELECTRICAL SPECIFICATIONS

Parameter	Test Conditions ①	MSK 130			Units
		Min.	Typ. ③	Max.	
STATIC					
Supply Voltage Range ② ④	Total + V_{CC} to - V_{CC}	20	-	400	V
Quiescent Current	$V_{IN} = 0V$	-	±6	±8	mA
INPUT					
Input Offset Voltage	$V_{IN} = 0V$	-	±0.5	±2.0	mV
Input Offset Voltage Drift ②	$V_{IN} = 0V$	-	±10	±50	μV/°C
Input Bias Current ②	$V_{CM} = 0V$ Either Input	-	±10	±200	pA
Input Offset Current ②	$V_{CM} = 0V$	-	10	50	pA
Input Impedance	F = DC	-	10 ¹¹	-	Ω
Input Capacitance	Either Input	-	4.0	-	pF
Power Supply Rejection Ratio ②	Δ $V_{CC} = ±15V$	-	±10	±20	μV/V
Common Mode Rejection Ratio ②	F = DC $V_{CM} = ±50V$	80	90	-	dB
Common Mode Range ②	Linear Operation	± $V_{CC}-15$	± $V_{CC}-13$	-	V
Input Noise Voltage	F = 100KHz	-	1.5	-	μVrms
OUTPUT					
Output Voltage Swing	$I_{OUT} = ±50mA$	±91.5	±95	-	V
Output Current ②	Within SOA	±200	±250	-	mA
Output Resistance	f ≤ 10KHz, No Load	-	50	-	Ω
TRANSFER CHARACTERISTICS					
Slew Rate Limit	$A_V = 100v/v$ $C_C = 0pF$	-	300	-	V/μS
Open Loop Voltage Gain ②	F = 15Hz $C_C = 0pF$	95	110	-	dB
Settling Time to 0.1%	$R_L = 1KΩ$ 2V step $C_C = 10pF$	-	1	-	μS

NOTES:

- ① ± $V_{CC} = ±100V$, $T_C = 25°C$, $R_C = 100Ω$, $C_C = 68pF$ unless otherwise specified.
- ② Devices shall be capable of meeting the parameter, but need not be tested.
- ③ Typical parameters are representative of actual device performance but are for reference only.
- ④ Maximum supply voltage should be derated 0.625V/°C below 25°C case temperature.

APPLICATION NOTES

SAFE OPERATING AREA

The output stage of the MSK 130 is fabricated using state of the art complimentary MOSFETs and is free from secondary breakdown limitations. There are two distinct limitations for the output stage:

1. The internal wire bonds and the geometry of the MOSFET have a maximum peak current capability of $\pm 300\text{mA}$.
2. The junction temperature of each MOSFET should be kept below the maximum rating of 150°C .

The SOA Curves below illustrate various conditions of power dissipation.

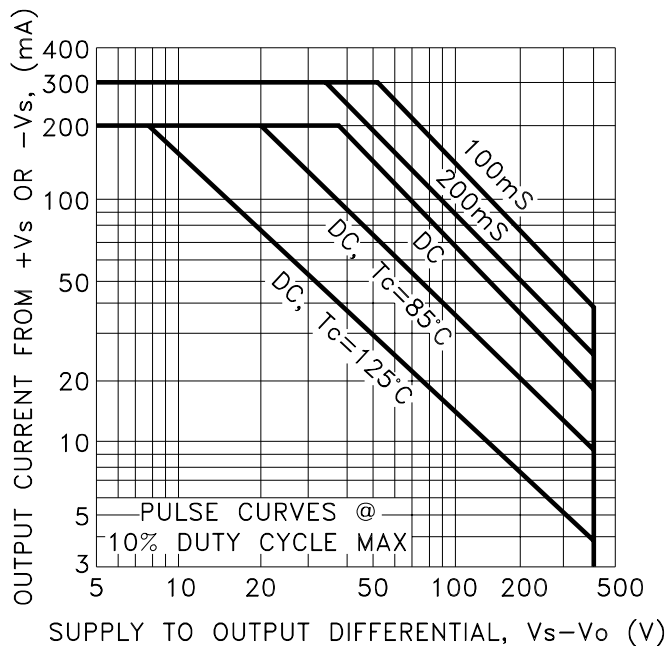

INPUT PROTECTION

The MSK 130 can safely handle up to $\pm 25\text{V}$ of differential input voltages. In applications where this may be violated, external protection is required. Four diodes can be used as shown in the typical connection diagram. If leakage current is of concern, use JFETs connected as diodes instead. JFETs will also yield very low capacitance for high speed applications.

CURRENT LIMIT

The MSK 130 has an internal active current limit circuit that can be programmed with a single external resistor R_{sc} . The value of this resistor should be kept between 2Ω and 150Ω . The following equation is used to select the resistor for a given current limit value:

$$R_{sc} = 0.6/I_{LIMIT} \text{ (See Typical Connection Diagram)}$$

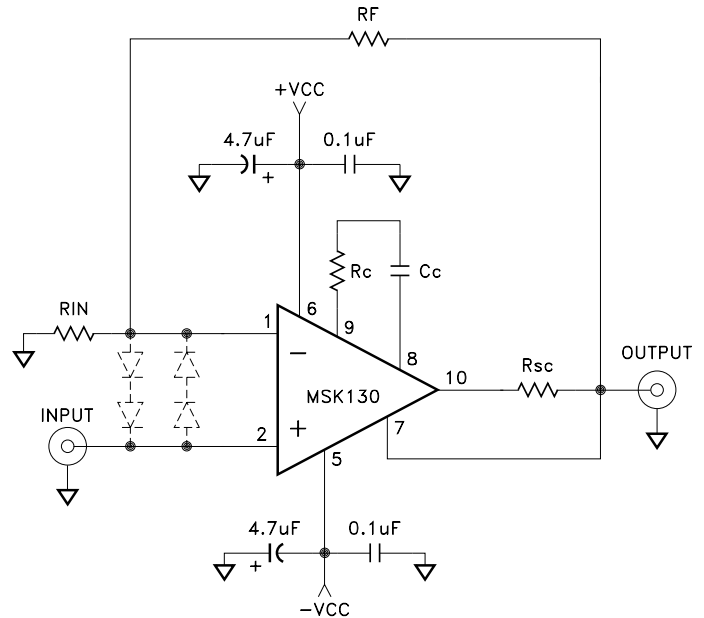

TYPICAL CONNECTION DIAGRAM

STABILITY AND COMPENSATION

Since the MSK 130 is externally compensated the bandwidth can be optimized for any gain selection. The external compensation components should be located as close to the compensation pins as possible to avoid unwanted oscillations. The capacitor C_c should be rated for the full supply voltage. Use a high quality dielectric such as NPO to maintain a desired compensation over the full operating temperature. Refer to the typical performance curves for a guide to select the desired compensation. Refer to the typical connection diagram for the location of the R_c and C_c components.

POWER SUPPLIES

Both the negative and positive power supplies must be effectively decoupled with a high and low frequency bypass circuit to avoid power supply induced oscillation. An effective decoupling scheme consists of a 0.1 microfarad ceramic capacitor in parallel with a 4.7 microfarad tantalum capacitor for each power supply pin to ground. All power supply decoupling capacitors should be placed as close to the package power supply pins as possible (pins 5 and 6).

TYPICAL PERFORMANCE CURVES

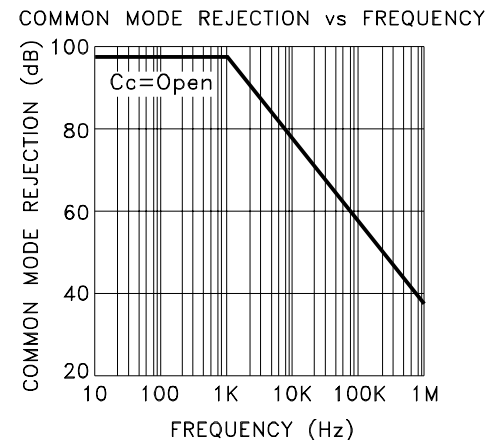
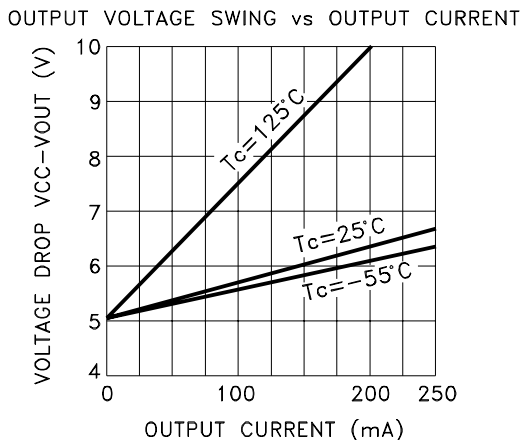
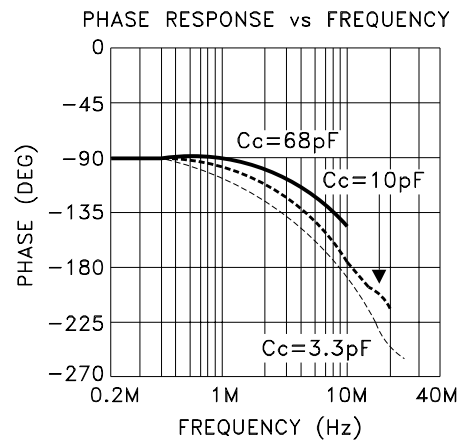
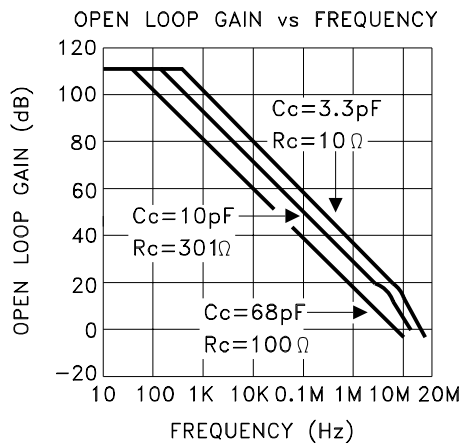
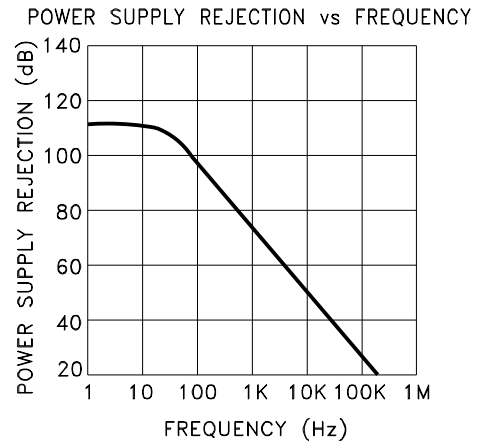
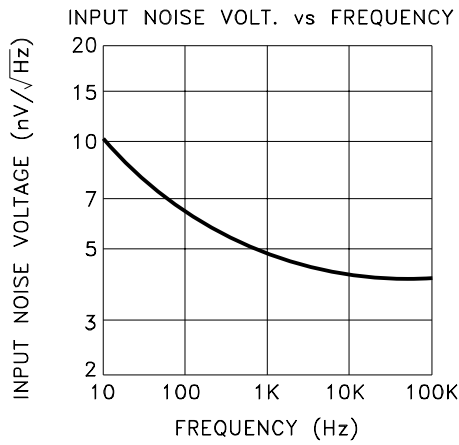
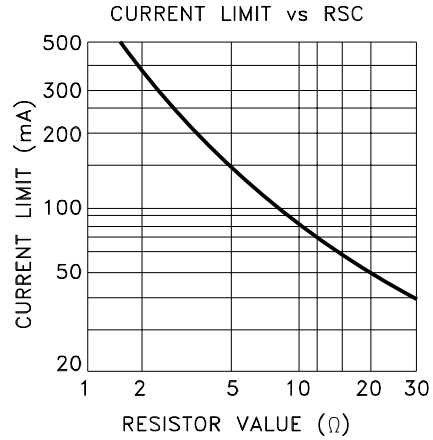
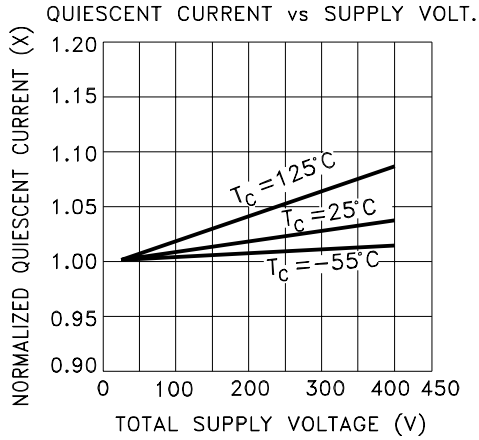

MECHANICAL SPECIFICATIONS

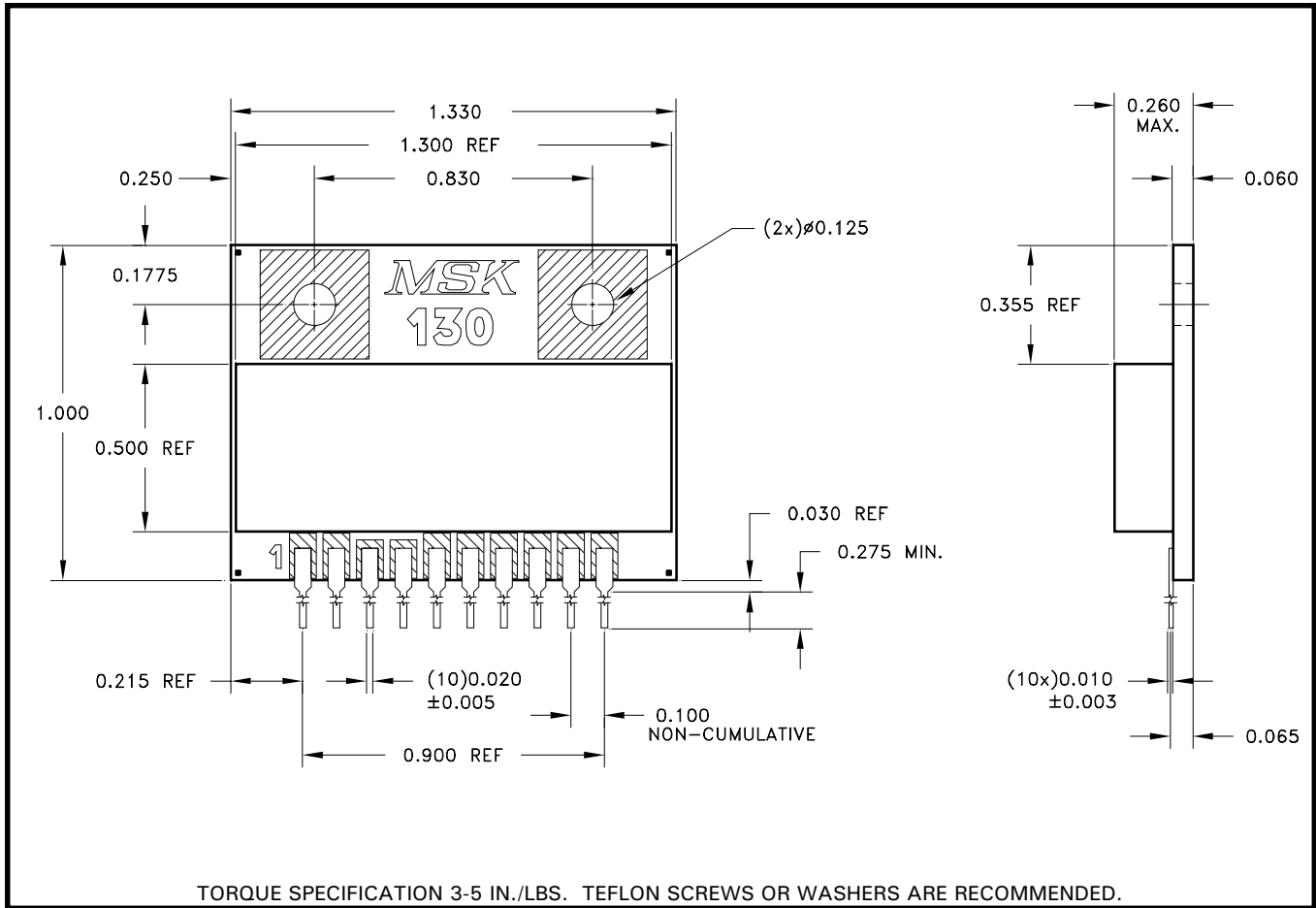

ALL DIMENSIONS ARE ± 0.010 INCHES UNLESS OTHERWISE LABELED

ORDERING INFORMATION

Part Number	Screening Level
MSK130	Industrial

M.S. Kennedy Corp.
 4707 Dey Road, Liverpool, New York 13088
 Phone (315) 701-6751
 FAX (315) 701-6752
www.mskennedy.com

The information contained herein is believed to be accurate at the time of printing. MSK reserves the right to make changes to its products or specifications without notice, however, and assumes no liability for the use of its products. Please visit our website for the most recent revision of this datasheet.