



M.S.KENNEDY CORP.

**RAD HARD  
HIGH PERFORMANCE  
DUAL COMPARATOR**

**119RH**

4707 Dey Road Liverpool, N.Y. 13088

(315) 701-6751

**FEATURES:**

- Manufactured using  Space Qualified RH119 Die
- MIL-PRF-38535 Class V Processing & Screening
- Total Dose Tested to TBD Krads(Si) (Method 1019.7 Condition A)
- Guaranteed Input Characteristics
- Input Protection Diodes
- 25mA Output Drive Capability
- Wide Supply Range
- Available in Straight or Gull Wing Lead Form
- Contact MSK for MIL-PRF-38535 Qualification and Radiation Status

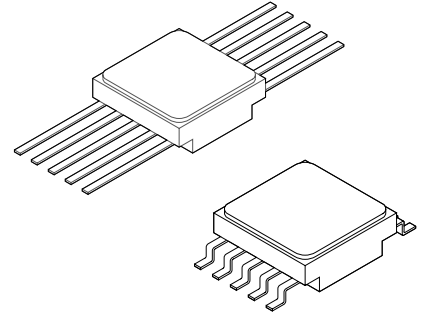

**DESCRIPTION:**

The MSK 119RH is a radiation hardened general purpose dual comparator with a wide input supply range of a single 5V to  $\pm 15V$ . The comparators offer guaranteed input characteristics over the full temperature range and input protection diodes. The output transistors are capable of driving loads to 25mA. System grounds can be isolated utilizing the comparators separate ground pins. The MSK 119RH is packaged in a space saving surface mount ceramic package with straight or gull wing lead form.

**EQUIVALENT SCHEMATIC**

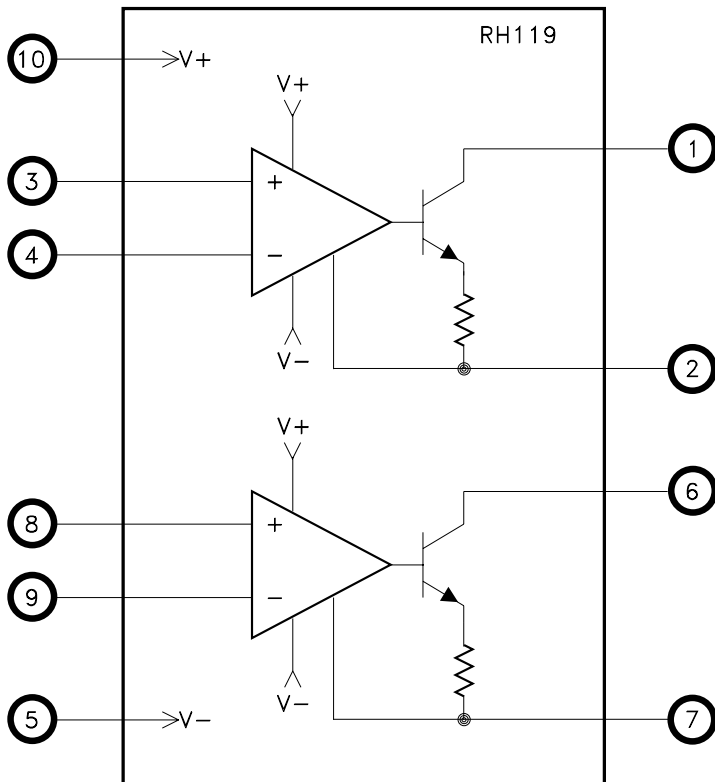

**TYPICAL APPLICATIONS**

- Window Detector
- Relay/Lamp Driver
- Voltage Controlled Oscillator
- High Speed One Shot

**PIN-OUT INFORMATION**

1	OUT 1	10	V+
2	GND 1	9	- IN 2
3	+ IN 1	8	+ IN 2
4	- IN 1	7	GND 2
5	V-	6	OUT 2

## ABSOLUTE MAXIMUM RATINGS <sup>⑦</sup>

Supply Voltage . . . . . 36V  
 Output to Negative Supply Voltage . . . . . 36V  
 Ground to Negative Supply Voltage . . . . . 25V  
 Ground to Positive Supply Voltage . . . . . 18V  
 Differential Input Current . . . . . ± 5mA  
 Differential Input Voltage . . . . . ± 5V

T<sub>LD</sub> Lead Temperature Range  
 (10 Seconds) . . . . . 300 °C  
 T<sub>J</sub> Junction Temperature . . . . . 150 °C  
 T<sub>ST</sub> Storage Temperature Range . . -65 °C to + 150 °C  
 T<sub>C</sub> Case Operating Temperature Range  
 MSK 119VRH . . . . . -55 °C to + 125 °C  
 MSK 119RH . . . . . -40 °C to + 85 °C

## ELECTRICAL SPECIFICATIONS

Parameter	Test Conditions <sup>①</sup> <sup>⑥</sup>	Group A	MSK 119VRH			MSK 119RH			Units
		Subgroup	Min.	Typ.	Max.	Min.	Typ.	Max.	
Input Offset Voltage	I <sub>Load</sub> = 1mA	1	-	-	4	-	-	4	mV
		2,3	-	-	7	-	-	-	mV
		Post Radiation	1	-	-	4	-	-	4
Input Offset Current	I <sub>Load</sub> = 1mA	1	-	-	75	-	-	75	nA
		2,3	-	-	100	-	-	-	nA
		Post Radiation	1	-	-	300	-	-	300
Input Bias Current	Post Radiation	1	-	-	500	-	-	500	nA
		2,3	-	-	1000	-	-	-	nA
		1	-	-	1500	-	-	1500	nA
Voltage Gain <sup>②</sup>		4	10	-	-	10	-	-	V/mV
Common Mode Rejection Ratio <sup>②</sup>		1	90	-	-	90	-	-	dB
Saturation Voltage	V <sub>+</sub> = 5V V <sub>-</sub> = 0V V <sub>in</sub> = -6mV I <sub>sink</sub> = 3mA	1	-	-	0.4	-	-	0.4	V
		2	-	-	0.4	-	-	-	V
		3	-	-	0.6	-	-	-	V
		1	-	-	1.5	-	-	1.5	V
Response Time	V <sub>in</sub> = 100mV step with 5mV OD	4	-	-	200	-	-	200	nS
		5,6	-	-	200	-	-	-	nS
Supply Current <sup>②</sup>	V <sub>+</sub> = 5V V <sub>-</sub> = 0V	-	-	4.3	-	-	4.3	-	mA
Positive Supply Current	V <sub>±</sub> = ±15V	1	-	-	11.5	-	-	11.5	mA
Negative Supply Current	V <sub>±</sub> = ±15V	1	-	-	4.5	-	-	4.5	mA
Output Leakage Current	V <sub>+</sub> = 15V V <sub>-</sub> = -20V V <sub>in</sub> = 5mV	1	-	-	2	-	-	2	µA
		2,3	-	-	10	-	-	-	µA
Input Voltage Range <sup>②</sup>	V <sub>±</sub> = ±15V	1	-12	-	12	-12	-	12	V
		2,3	-12	-	12	-	-	-	V
		1	1	-	3	1	-	3	V
		2,3	1	-	3	-	-	-	V
Thermal Resistance <sup>②</sup>	Junction to Case @125 °C	-	-	34.1	40.0	-	34.1	40.0	°C/W

### NOTES:

- ① Unless otherwise specified, V<sub>±</sub> = ± 15V, V<sub>cm</sub> = 0V
- ② Guaranteed by design but not tested. Typical parameters are representative of actual device performance but are for reference only.
- ③ Industrial grade devices shall be tested to subgroup 1 unless otherwise specified.
- ④ Military grade devices (V Suffix) shall be 100% tested to subgroups 1,2,3 and 4.
- ⑤ Subgroups 5 and 6 testing available upon request.
- ⑥ Subgroup 1,4 TA = TC = + 25 °C  
 Subgroup 2,5 TA = TC = + 125 °C  
 Subgroup 3,6 TA = TC = -55 °C
- ⑦ Continuous operation at or above absolute maximum ratings may adversely effect the device performance and/or life cycle.
- ⑧ Pre and Post irradiation limits at 25 °C, up to TBD TID, are identical unless otherwise specified.

## APPLICATION NOTES

### ISOLATED GROUNDS

Unlike typical comparators, each comparator in the MSK 119RH has its own isolated ground pin. This allows the output to be referenced to levels other than the negative supply rail. This feature allows each comparator to operate with its input and output at different parts of the system ground without adverse interaction. See the absolute maximum ratings for maximum voltage potential of the ground pins with respect to the supply rails.

### DRIVING POSITIVE OR NEGATIVE SUPPLY REFERENCED LOADS

The MSK 119RH's floating output transistor allows the load to be referenced to either a positive or negative supply. The floating output stage has the flexibility to interface to multiple logic families and loads. The output transistor has the added benefit of no current flowing through it when the output pin is pulled up with a positive referenced supply configuration or the GND pin is pulled down with a negative referenced supply configuration. Figure 2 shows a typical load connected to the output pin referenced to VPU, with the GND pin either connected to -VCC or ground. A separate supplied voltage applied to Vpu can be greater than VCC as long as the output to negative supply absolute maximum rating is not exceeded.

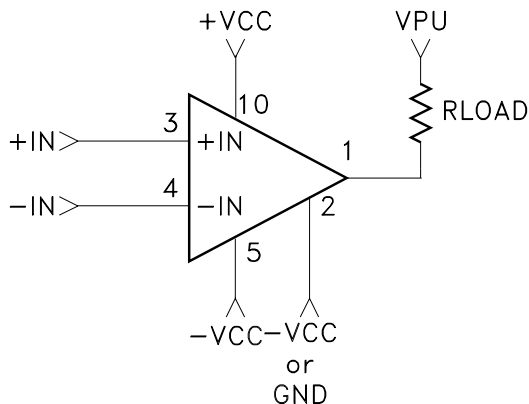

FIGURE 2

Figure 3 shows a load referenced to a negative supply or ground where the output is taken from the MSK 119RH GND pin (output transistor emitter). For this configuration, the GND pin voltage is approximately 2V less than VPU when conducting current. Since the output at the emitter has reverse phasing with respect to the collector output, the + INPUT (pin 3/8) and - INPUT pin (pin 4/9) must reverse their input designations as shown.

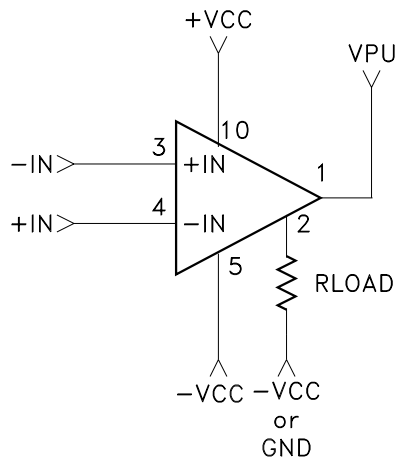

FIGURE 3

In both configurations the ground pin potential must remain within maximum ratings. See absolute maximum ratings.

### TOTAL DOSE RADIATION TEST PERFORMANCE

Radiation performance curves for TID testing will be generated for all radiation testing performed by MS Kennedy. These curves show performance trends throughout the TID test process and can be located in the MSK 119RH radiation test report. The complete radiation test report will be available in the RAD HARD PRODUCTS section on the MSK website.

### ADDITIONAL APPLICATION INFORMATION

For additional applications information, please reference Linear Technology Corporation's® LT119 and RH119 data sheets.

# TYPICAL PERFORMANCE CURVES

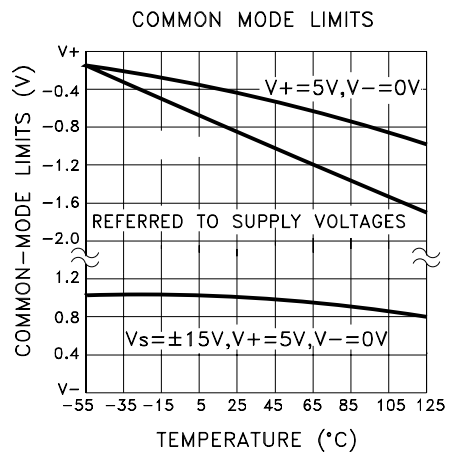
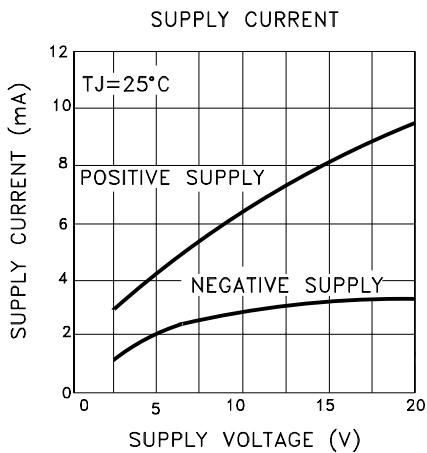
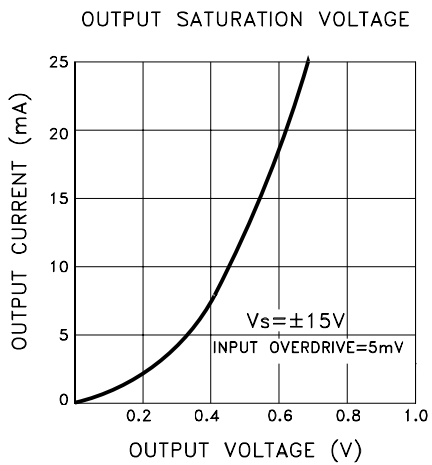
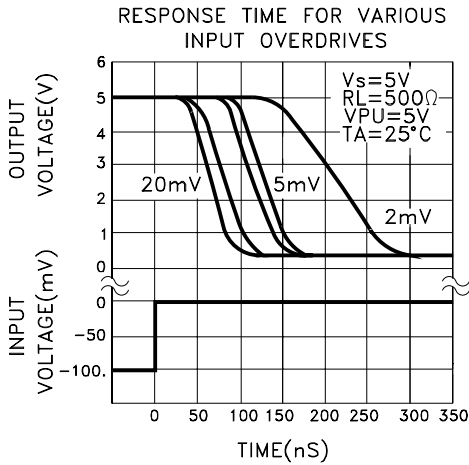
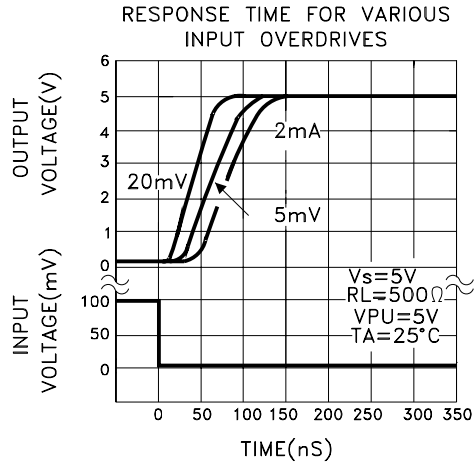
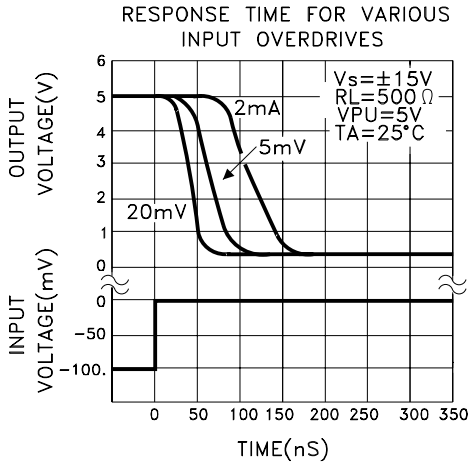
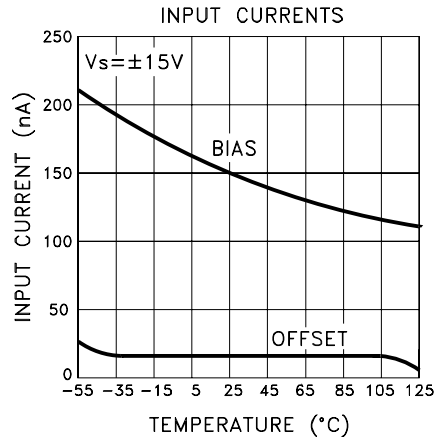
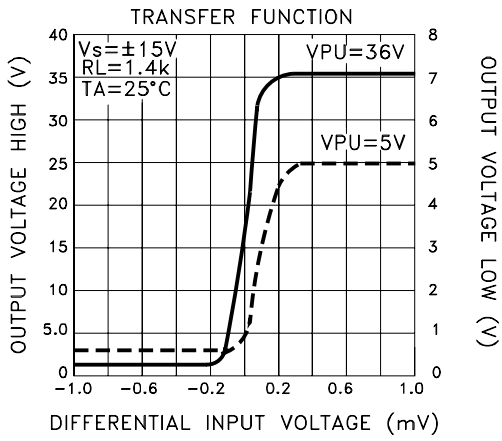

# MECHANICAL SPECIFICATIONS

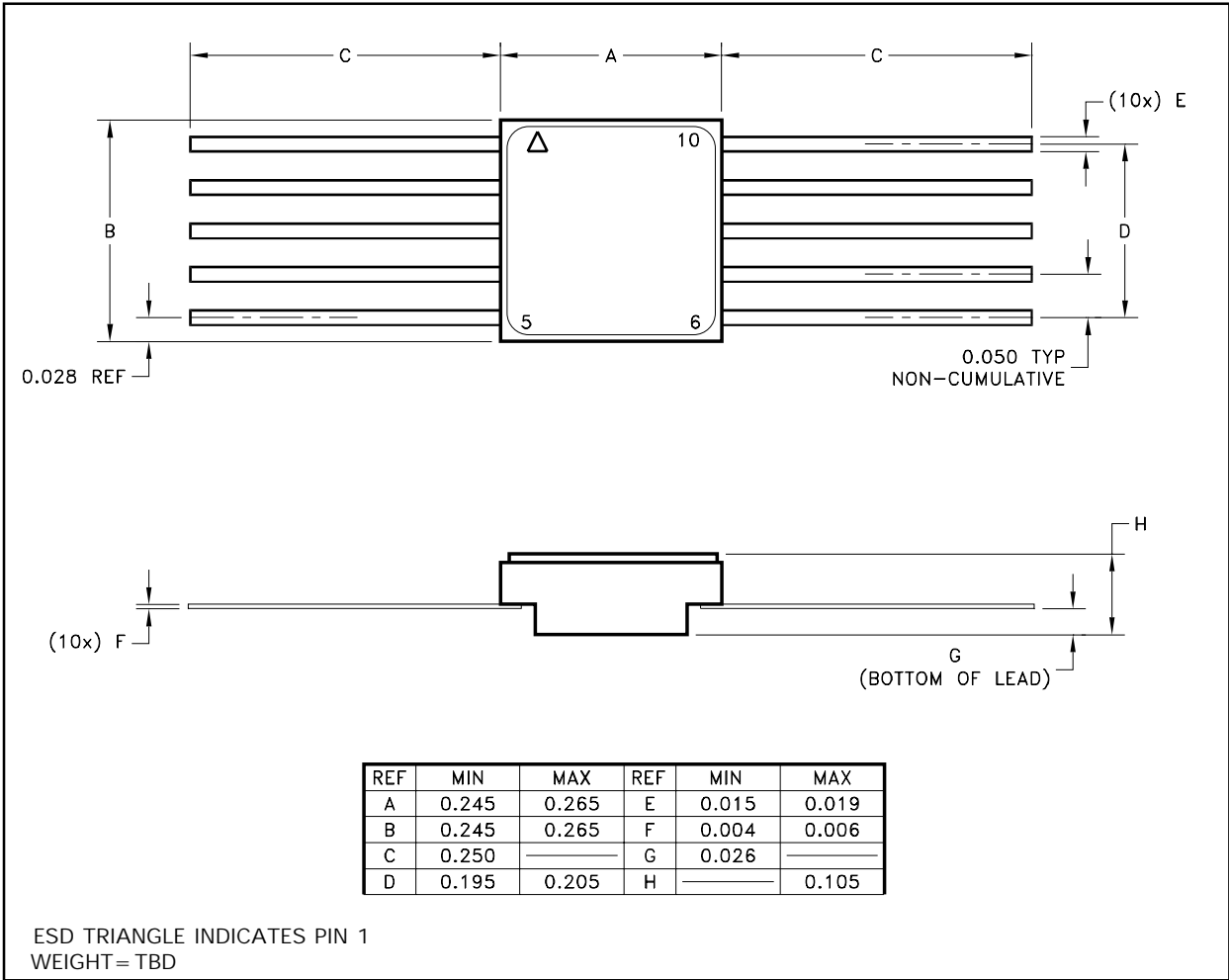

## ORDERING INFORMATION

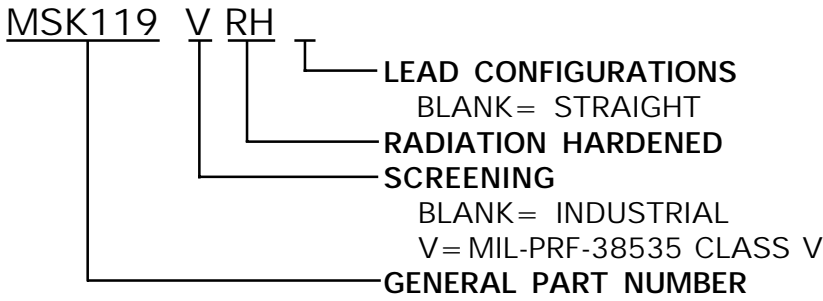

The above example is a Class V dual comparator with straight leads.

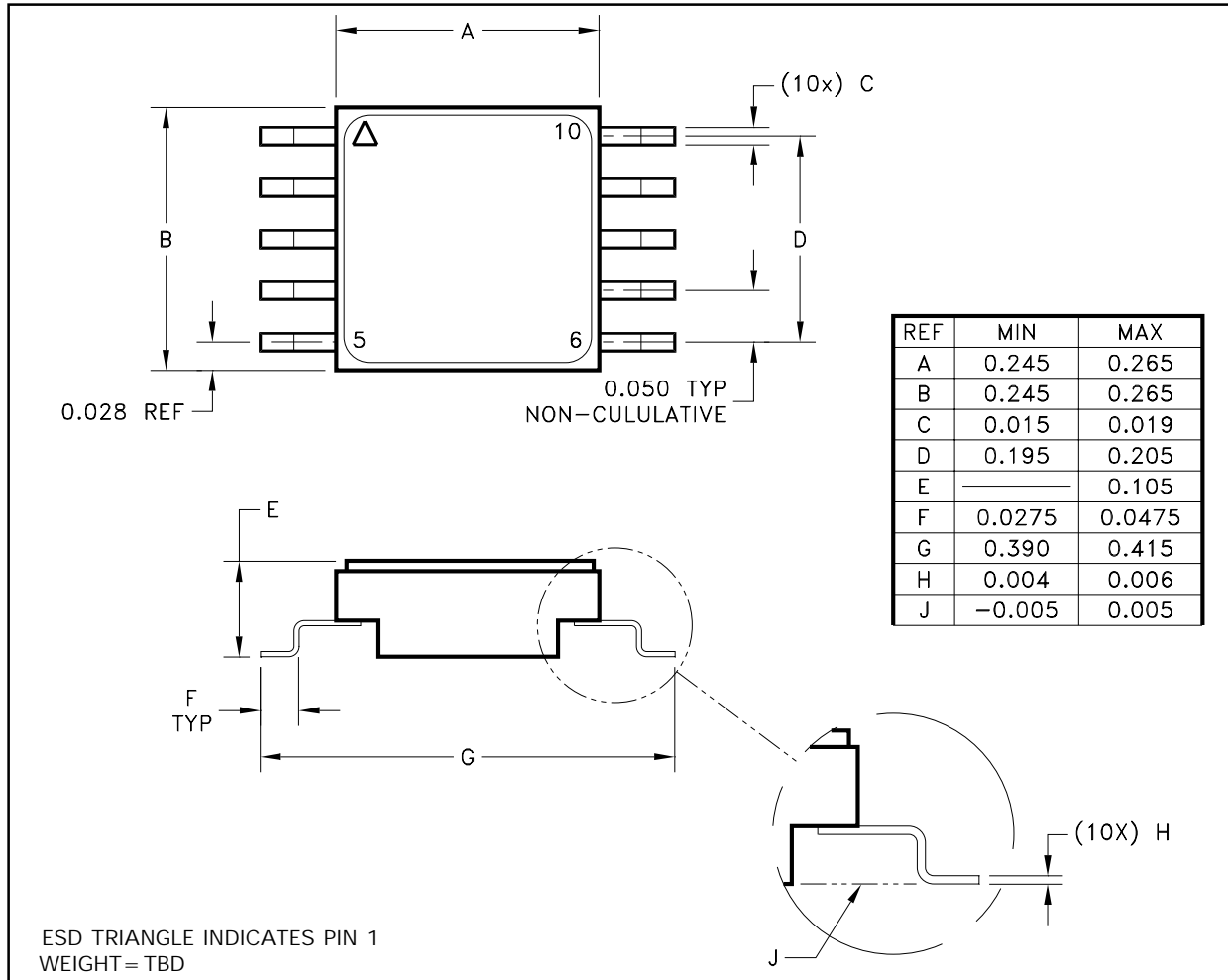

## ORDERING INFORMATION

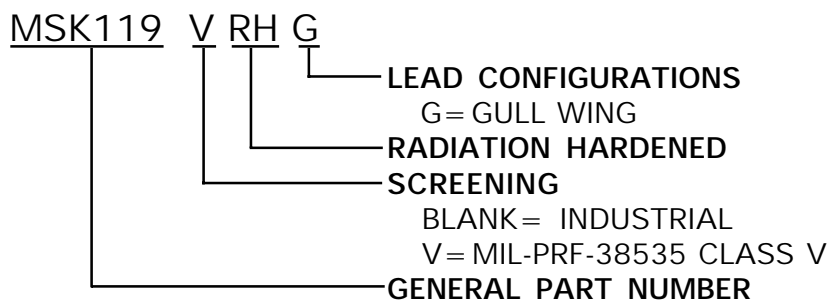

The above example is a Class V dual comparator with gull wing lead form.

M.S. Kennedy Corp.  
4707 Dey Road, Liverpool, New York 13088  
Phone (315) 701-6751  
FAX (315) 701-6752  
www.mskennedy.com

The information contained herein is believed to be accurate at the time of printing. MSK reserves the right to make changes to its products or specifications without notice, however, and assumes no liability for the use of its products. Please visit our website for the most recent revision of this datasheet. Contact MSK for MIL-PRF-38535 Class V and radiation status.