



M. S. KENNEDY CORP.

POWER OPERATIONAL AMPLIFIER

115

4707 Dey Road Liverpool, N.Y. 13088

(315) 701-6751

FEATURES:

- High Output Current - 15A peak
- Ultra Low Thermal Resistance - 0.43° C/W Typ.
- Excellent Linearity - Class A/B Output
- Wide Supply Range - $\pm 10V$ to $\pm 50V$
- High Output Power Dissipation Capability
- Output Short Circuit Protected
- User Programmable Current Limit
- Isolated Case Allows Direct Heat Sinking
- Low Quiescent Current - $\pm 22mA$. Typ.
- Contact MSK for MIL-PRF-38534 Qualification Status

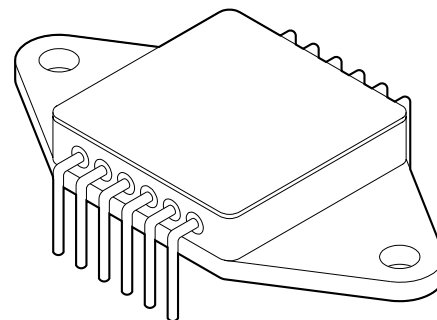

DESCRIPTION:

The MSK 115 is a High Power Operational Amplifier. Due to the extremely low thermal resistance from the transistor junctions to the case, the MSK 115 can dissipate extreme amounts of power at a case temperature of 125°C. The amplifier is packaged in a hermetic plug in power package with isolated, bolt down tabs.

EQUIVALENT SCHEMATIC

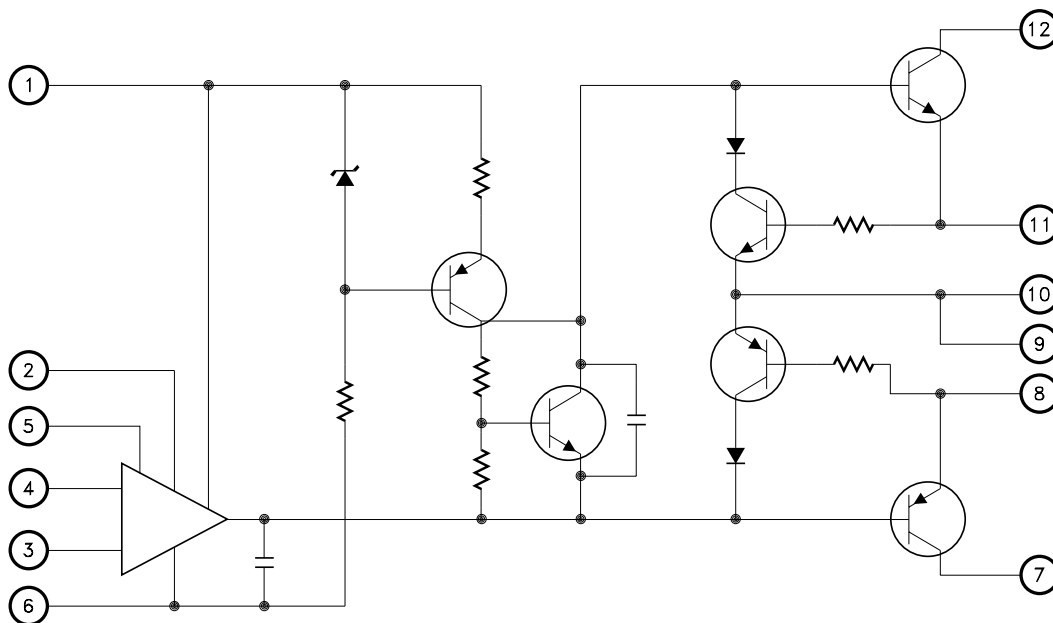

TYPICAL APPLICATIONS

- Magnetic Deflection Circuit Driver
- Programmable Power Supplies
- Motor, Valve and Actuator Control
- Audio Amplifier

PIN-OUT INFORMATION

1 + Vcc	12 + Vc
2 Balance	11 + Current Limit
3 Inverting Input	10 Output
4 Non-Inverting Input	9 Output
5 Balance	8 -Current Limit
6 -Vcc	7 -Vc

ABSOLUTE MAXIMUM RATINGS ^⑧

$\pm V_{CC}$	Supply Voltage	$\pm 50V$
I_{OUT}	Output Current	15A
V_{IN}	Differential Input Voltage	$\pm 37V$
T_C	Case Operating Temperature Range (MSK 115B/E)	$-55^{\circ}C$ to $+125^{\circ}C$
	(MSK 115)	$-40^{\circ}C$ to $+85^{\circ}C$

T_{ST}	Storage Temperature Range	$-65^{\circ}C$ to $+150^{\circ}C$
T_{LD}	Lead Temperature Range	$300^{\circ}C$ (10 Seconds)
P_D	Power Dissipation	See S0A Curve
T_J	Junction Temperature	$175^{\circ}C$

ELECTRICAL SPECIFICATIONS

Parameter	Test Conditions ^①	Group A Subgroup	MSK 115B/E			MSK 115			Units
			Min.	Typ.	Max.	Min.	Typ.	Max.	
STATIC									
Supply Voltage Range ^③		-	± 10	-	± 50	± 10	-	± 45	V
Quiescent Current	$V_{IN} = 0V$	1	-	± 22	± 35	-	± 22	± 40	mA
	$A_V = -10V/V$	2,3	-	± 28	± 45	-	-	-	mA
Thermal Resistance ^③	Junction to Case @ $25^{\circ}C$	-	-	0.43	0.55	-	0.43	0.6	$^{\circ}C/W$
INPUT									
Input Offset Voltage	$V_{IN} = 0V$ $A_V = 10V/V$	1	-	± 2	± 6	-	± 2	± 10	mV
	Bal. Pins = NC	2,3	-	± 3	± 12	-	-	-	mV
Input Offset Adjust	$R_{POT} = 10K\Omega$ Wiper to $-V_{CC}$	7	Adjust to zero			Adjust to zero			mV
	$A_V = -10V/V$	8A,8B	Adjust to zero			-	-	-	mV
Input Bias Current	$V_{CM} = 0V$	1	-	± 10	± 30	-	± 10	± 50	nA
	Either Input	2,3	-	± 15	± 60	-	-	-	nA
Input Offset Current	$V_{CM} = 0V$	1	-	± 5	± 30	-	± 5	± 50	nA
		2,3	-	± 10	± 50	-	-	-	nA
Input Impedance ^③	$F = DC$	-	50	250	-	35	250	-	$M\Omega$
Common Mode Range ^③		-	-	± 35	-	-	± 35	-	V
Common Mode Rejection Ratio ^③	$F = 100Hz$ $V_{CM} = \pm 5V$	-	80	100	-	74	100	-	dB
OUTPUT									
Output Voltage Swing	$R_L = 500\Omega$ $A_V = -10V/V$	4	± 35	± 37	-	± 33	± 37	-	V
	^③ $R_L = 10\Omega$ $R_{SC} = 0\Omega$	-	± 35	± 36	-	± 33	± 36	-	V
Output Current, Peak	$A_V = -10V/V$ $V_{OUT} = MAX$	4	15	-	-	10	-	-	A
Settling Time ^② ^③	0.1% 10V step	-	-	2	-	-	5	-	μS
TRANSFER CHARACTERISTICS									
Slew Rate	$V_{OUT} = \pm 10V$ $R_L = 500\Omega$ $A_V = -10V/V$	4	2.5	5	-	1	2.5	-	$V/\mu S$
Open Loop Voltage Gain ^③	$R_L = 500\Omega$ $F = 10Hz$	4	95	105	-	85	105	-	dB
Gain Bandwidth Product ^③	$R_L = 10\Omega$ $F = 1 MHz$	-	-	4	-	-	3	-	MHz

NOTES:

- ① Unless otherwise specified, $\pm V_{CC} = \pm 40V_{DC}$
- ② $A_V = -1$, measured in false summing junction circuit.
- ③ Guaranteed by design but not tested. Typical parameters are representative of actual device performance but are for reference only.
- ④ Industrial grade and "E" suffix devices shall be tested to subgroups 1,4 and 7 unless otherwise specified.
- ⑤ Military grade devices ("B" suffix) shall be 100% tested to subgroups 1,2,3,4,7,8A and 8B.
- ⑥ Subgroups 5 and 6 testing available upon request.
- ⑦ Subgroup 1,4,7 $T_A = T_C = +25^{\circ}C$
Subgroup 2,5,8A $T_A = T_C = +125^{\circ}C$
Subgroup 3,6,8B $T_A = T_C = -55^{\circ}C$
- ⑧ Continuous operation at or above absolute maximum ratings may adversely effect the device performance and/or life cycle.

APPLICATION NOTES

HEAT SINKING

To determine if a heat sink is necessary for your application and if so, what type, refer to the thermal model and governing equation below.

Thermal Model:

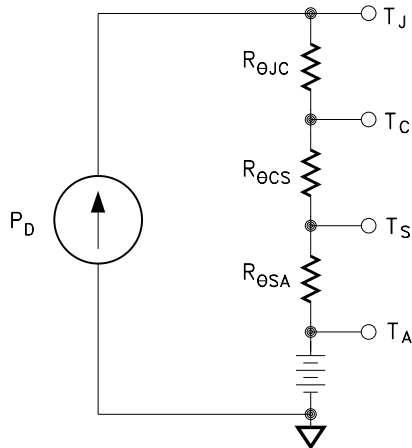

Governing Equation:

$$T_J = P_D \times (R_{\theta JC} + R_{\theta CS} + R_{\theta SA}) + T_A$$

Where

T_J = Junction Temperature

P_D = Total Power Dissipation

$R_{\theta JC}$ = Junction to Case Thermal Resistance

$R_{\theta CS}$ = Case to Heat Sink Thermal Resistance

$R_{\theta SA}$ = Heat Sink to Ambient Thermal Resistance

T_C = Case Temperature

T_A = Ambient Temperature

T_S = Sink Temperature

Example:

In our example the amplifier application requires the output to drive a 20 volt peak sine wave across a 20 ohm load for 1 amp of output current. For a worst case analysis we will treat the 1 amp peak output current as a D.C. output current. The power supplies are ± 40 VDC.

1.) Find Power Dissipation

$$\begin{aligned} P_D &= [(\text{quiescent current}) \times (V_s - (V_s))] + [(+V_s - V_o) \times I_{out}] \\ &= (25\text{mA}) \times (80\text{V}) + (20\text{V}) \times (1\text{A}) \\ &= 2\text{W} + 20\text{W} \\ &= 22\text{W} \end{aligned}$$

2.) For conservative design, set $T_J = +125^\circ\text{C}$

3.) For this example, worst case $T_A = +50^\circ\text{C}$

4.) $R_{\theta JC} = 0.55^\circ\text{C/W}$ from MSK 115B Data Sheet

5.) $R_{\theta CS} = 0.15^\circ\text{C/W}$ for most thermal greases

6.) Rearrange governing equation to solve for $R_{\theta SA}$

$$\begin{aligned} R_{\theta SA} &= ((T_J - T_A) / P_D) - (R_{\theta JC}) - (R_{\theta CS}) \\ &= ((125^\circ\text{C} - 50^\circ\text{C}) / 22\text{W}) - (0.55^\circ\text{C/W}) - (0.15^\circ\text{C/W}) \\ &= 2.71^\circ\text{C/W} \end{aligned}$$

The heat sink in this example must have a thermal resistance of no more than 2.71°C/W to maintain a junction temperature of no more than $+125^\circ\text{C}$.

CURRENT LIMIT

The MSK 115 has an on-board current limit scheme designed to shut off the output drivers anytime output current exceeds a predetermined limit. The following formula may be used to determine the value of current limit resistance necessary to establish the desired current limit.

$$R_{CL} = (\text{OHMS}) = (0.65 \text{ volts/current limit in amps}) - 0.01\text{OHM}$$

The 0.01 ohm term takes into account any wire bond and lead resistance. Since the 0.65 volt term is obtained from the base emitter voltage drop of a bipolar transistor: the equation only holds true for operation at $+25^\circ\text{C}$ case temperature. The curve below illustrates the effect of case temperature on current limit.

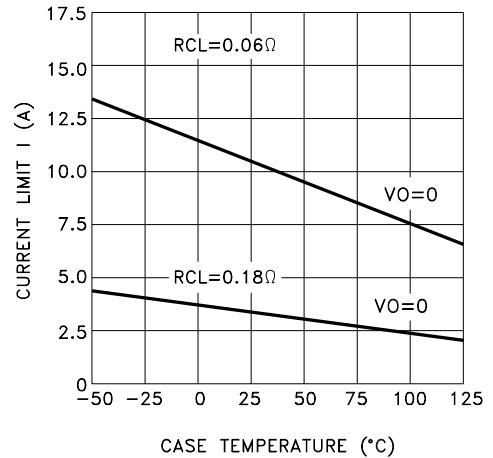

POWER SUPPLY BYPASSING

Both the negative and the positive power supplies must be effectively decoupled with a high and low frequency bypass circuit to avoid power supply induced oscillation. An effective decoupling scheme consists of a 0.1 microfarad ceramic capacitor in parallel with a 4.7 microfarad tantalum capacitor from each power supply pin to ground. It is also a good practice with very high power op-amps, such as the MSK 115, to place a 30-50 microfarad non-electrolytic capacitor with a low effective series resistance in parallel with the other two power supply decoupling capacitors. This capacitor will eliminate any peak output voltage clipping which may occur due to poor power supply load regulation. All power supply decoupling capacitors should be placed as close to the output stage power supply pins as possible (pins 7 and 12).

BALANCE PINS

Pins 2 & 5 of the MSK 115 are used to null unwanted input offset voltage. Connect as shown in the typical connection schematic. If the balance pins are not used, they should be left open/not connected.

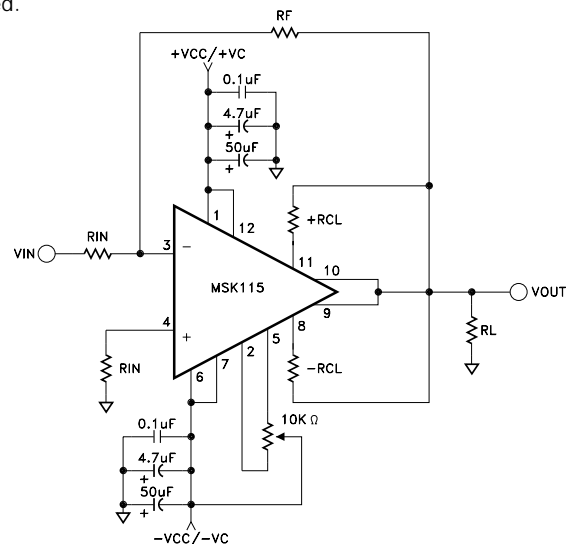

APPLICATION NOTES CONT'D

PIN DESCRIPTIONS		
NUMBER	NAME	FUNCTION
1	① +VCC	POSITIVE SUPPLY VOLTAGE FOR FRONT END OP-AMP
2	BALANCE	USED TO PROVIDE OFFSET VOLTAGE NULL. SEE APPLICATION NOTES
3	INVERTING INPUT	INVERTING INPUT FOR THE OP-AMP
4	NON-INVERTING INPUT	NON-INVERTING INPUT FOR THE OP-AMP
5	BALANCE	USED TO PROVIDE OFFSET VOLTAGE NULL. SEE APPLICATION NOTES
6	① -VCC	NEGATIVE SUPPLY VOLTAGE FOR FRONT END OP-AMP
7	① -VC	POWER SUPPLY CONNECTION TO THE COLLECTOR OF THE NEGATIVE OUTPUT TRANSISTOR. PROVIDES OUTPUT VOLTAGE/CURRENT
8	-CURRENT LIMIT (-CL)	USED TO PROVIDE CURRENT LIMIT PROTECTION TO THE NEGATIVE OUTPUT TRANSISTOR
9	OUTPUT	OP-AMP OUTPUT. CONNECT TO PIN 10 EXTERNALLY.
10	OUTPUT	OP-AMP OUTPUT. CONNECT TO PIN 9 EXTERNALLY.
11	+CURRENT LIMIT (+CL)	USED TO PROVIDE CURRENT LIMIT PROTECTION TO THE POSITIVE OUTPUT TRANSISTOR
12	① +VC	POWER SUPPLY CONNECTION TO THE COLLECTOR OF THE POSITIVE OUTPUT TRANSISTOR. PROVIDES OUTPUT VOLTAGE/CURRENT

- ① THE OUTPUT STAGE COLLECTORS (VC) ARE NORMALLY CONNECTED TO THE CORRESPONDING VCC PINS EXTERNALLY. THEY ARE BROUGHT OUT ON SEPERATE PINS FOR FLEXIBILITY FOR THE USER.

TYPICAL PERFORMANCE CURVES

QUIESCENT CURRENT vs. SUPPLY VOLTAGE

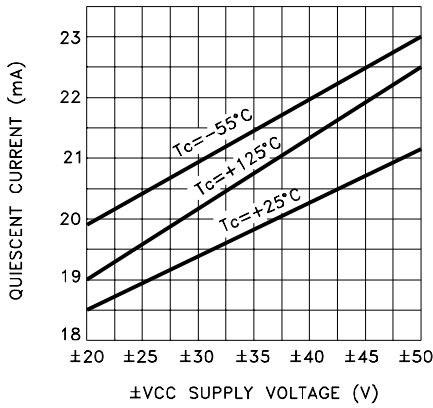

INPUT BIAS AND OFFSET CURRENT vs TEMPERATURE

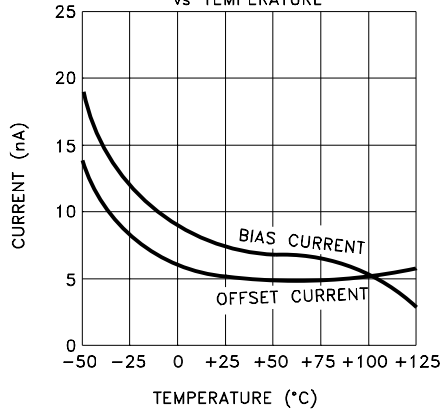

COMMON MODE REJECTION vs FREQUENCY

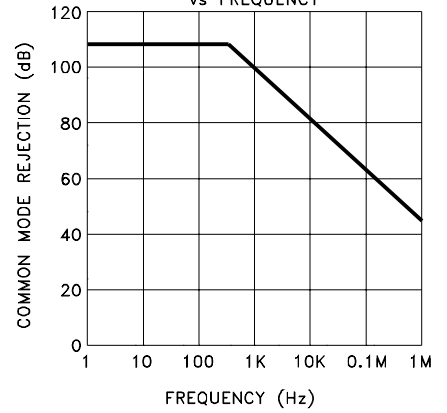

OUTPUT VOLTAGE SWING vs OUTPUT CURRENT

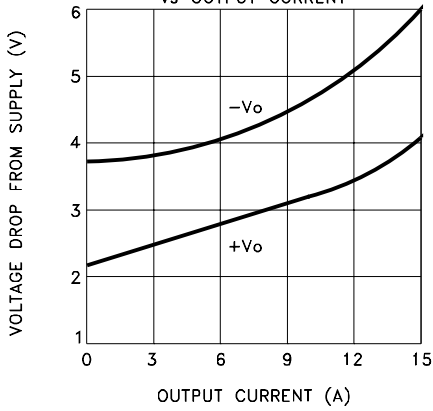

PULSE RESPONSE

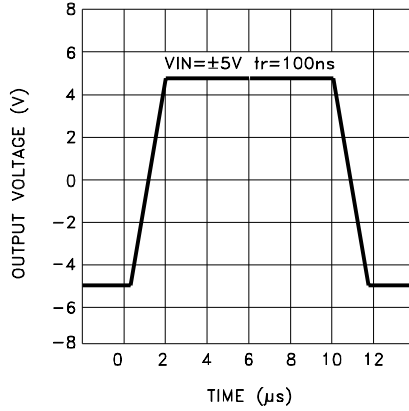

OPEN LOOP GAIN vs. FREQUENCY

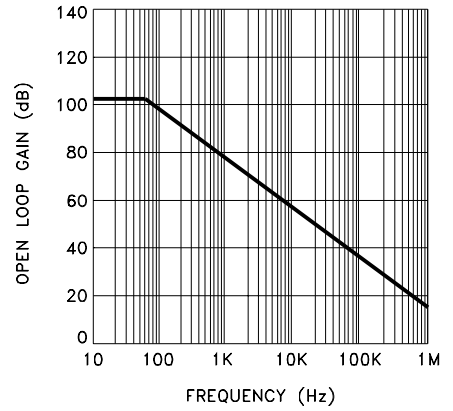

HARMONIC DISTORTION

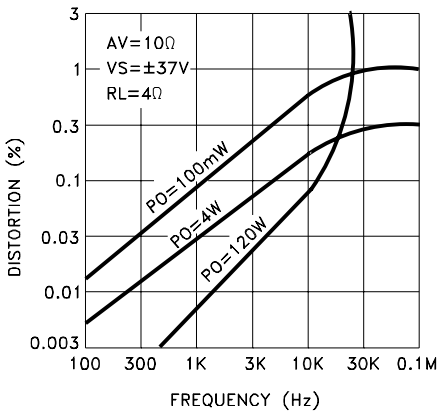

POWER RESPONSE vs FREQUENCY

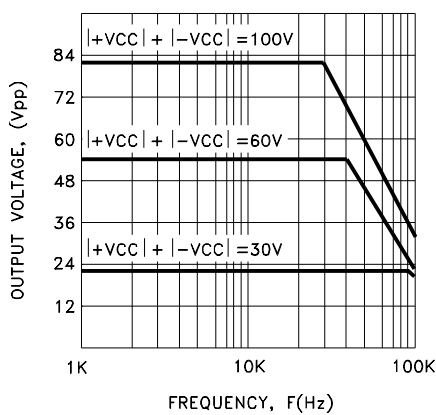

SOA CURVE

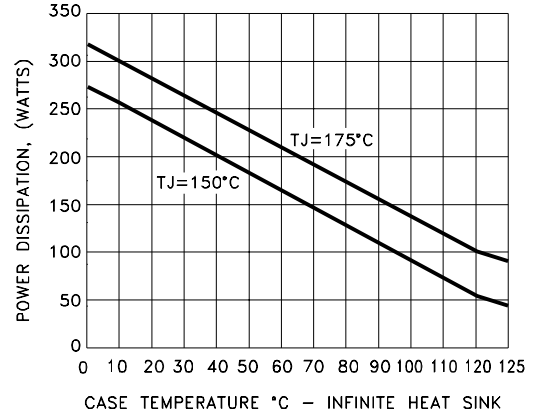

MECHANICAL SPECIFICATIONS

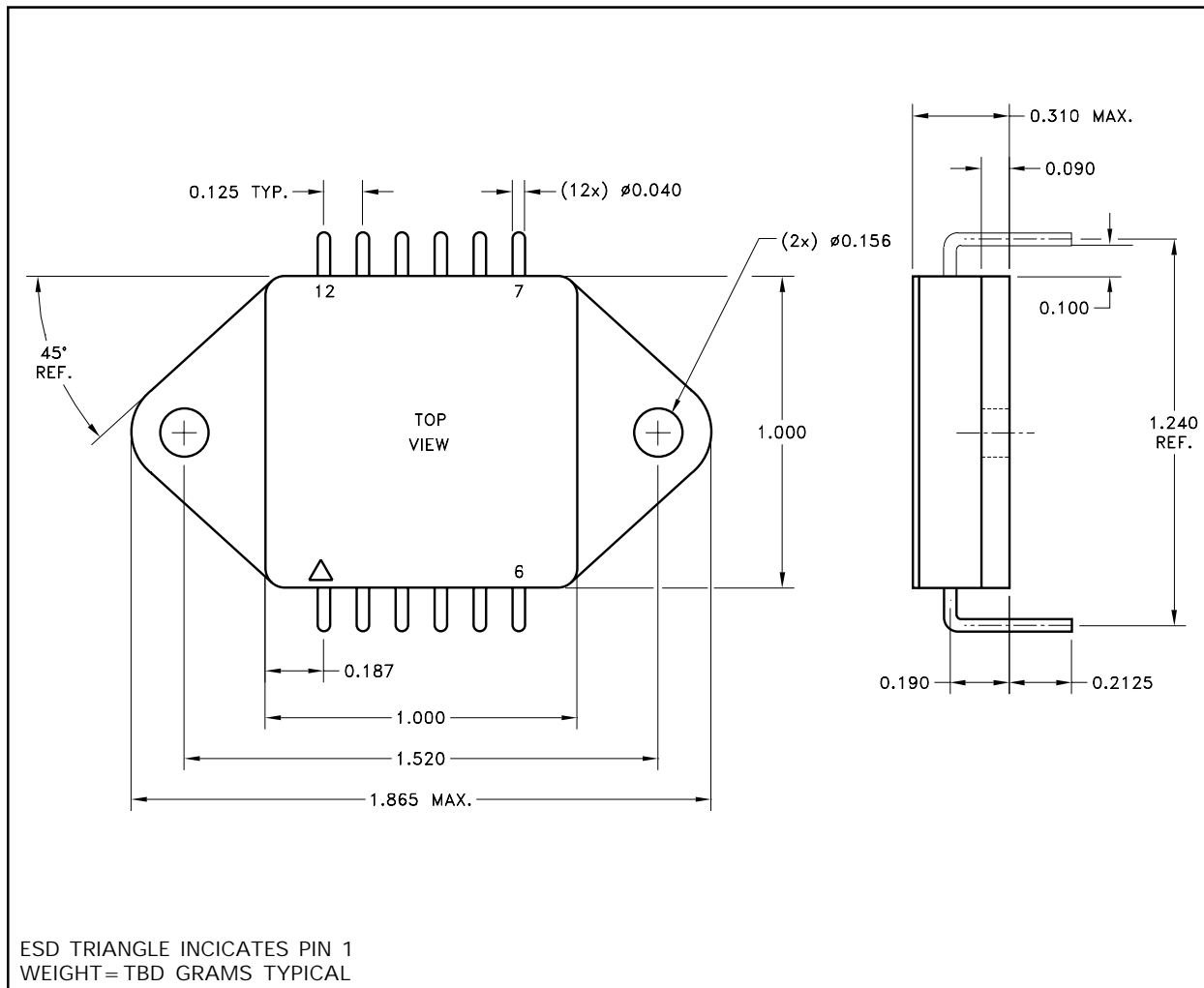

NOTE: ALL DIMENSIONS ARE ± 0.010 INCHES UNLESS OTHERWISE LABELED.

ORDERING INFORMATION

Part Number	Screening Level
MSK115	Industrial
MSK 115E	Extended Reliability
MSK115B	Mil-PRF-38534 Class H

M.S. Kennedy Corp.
4707 Dey Road, Liverpool, New York 13088
Phone (315) 701-6751
FAX (315) 701-6752
www.mskennedy.com

The information contained herein is believed to be accurate at the time of printing. MSK reserves the right to make changes to its products or specifications without notice, however, and assumes no liability for the use of its products.

Please visit our website for the most recent revision of this datasheet.

Contact MSK for MIL-PRF-38534 qualification status.